

*ΑΚΑΔΗΜΙΑ ΕΜΠΟΡΙΚΟΥ ΝΑΥΤΙΚΟΥ  
ΜΑΚΕΔΟΝΙΑΣ*

*ΘΕΜΑ ΠΤΥΧΙΑΚΗΣ*

*«Cargo handling in LNG carriers: safety and  
operational matters»*

*ΕΠΙΒΛΕΠΟΥΣΑ ΚΑΘΗΓΗΤΡΙΑ: ΠΑΠΑΛΕΩΝΙΔΑ  
ΠΑΡΑΣΚΕΥΗ*

*ΣΠΟΥΔΑΣΤΡΙΑ: ΜΑΝΟΥ ΕΥΑΓΓΕΛΙΑ*

*Ν. ΜΗΧΑΝΙΩΝΑ*

*2018*

**ΑΚΑΔΗΜΙΑ ΕΜΠΟΡΙΚΟΥ ΝΑΥΤΙΚΟΥ  
ΜΑΚΕΔΟΝΙΑΣ**

**ΣΧΟΛΗ ΠΛΟΙΑΡΧΩΝ**

**ΠΤΥΧΙΑΚΗ ΕΡΓΑΣΙΑ**

**ΘΕΜΑ:**

**"Cargo handling in LNG carriers: safety and operational matters"**

**ΕΠΙΒΛΕΠΟΥΣΑ ΚΑΘΗΓΗΤΡΙΑ: ΠΑΠΑΛΕΩΝΙΔΑ ΠΑΡΑΣΚΕΥΗ  
ΣΠΟΥΔΑΣΤΡΙΑ: ΜΑΝΟΥ ΕΥΑΓΓΕΛΙΑ  
Α.Γ.Μ.: 3610**

**Ημερομηνία ανάληψης της εργασίας: 09/05/2017**

**Ημερομηνία παράδοσης της εργασίας:**

<i>A/A</i>	<i>Όνοματεπώνυμο</i>	<i>Ειδικότης</i>	<i>Αξιολόγηση</i>	<i>Υπογραφή</i>
<b>1</b>	Capt. ΤΣΟΥΛΗΣ ΝΙΚΟΛΑΟΣ	<b>ΠΛΟΙΑΡΧΟΣ Α' Ε.Ν.</b>		
<b>2</b>	ΠΑΠΑΛΕΩΝΙΔΑ ΠΑΡΑΣΚΕΥΗ	<b>ΚΑΘΗΓΗΤΡΙΑ ΑΓΓΛΙΚΩΝ</b>		
<b>3</b>				
<b>ΤΕΛΙΚΗ ΑΞΙΟΛΟΓΗΣΗ</b>				

**Ο ΔΙΕΥΘΥΝΤΗΣ ΣΧΟΛΗΣ : ΤΣΟΥΛΗΣ ΝΙΚΟΛΑΟΣ**

# **CONTENTS**

## **ABSTRACT**

### **CHAPTER 1 FUNDAMENTAL KNOWLEDGE ABOUT LNG**

- 1.1 Introduction
- 1.2 LNG production
- 1.3 Use of Inert Gas and Nitrogen

### **CHAPTER 2 PROPERTIES OF LNG**

- 2.1 Chemical structure of gases
- 2.2 Physical properties and evaporation of LNG
- 2.3 Liquid / vapour densities and rollover effect
- 2.4 Flammability
- 2.5 Spillage of LNG

### **CHAPTER 3 DESIGN PRINCIPLES AND TYPE OF SHIPS**

- 3.1 History of ships carrying liquefied gases
- 3.2 Type of ships
- 3.3 Cargo containment systems, type of tanks and membranes
- 3.4 Cofferdams and Glycol system
- 3.5 Gas carrier layout

### **CHAPTER 4 SHIP'S EQUIPMENT AND SYSTEMS**

- 4.1 Cargo pipelines and valves
- 4.2 Cargo pumps

- 4.3 ESD System
- 4.4 HD / LD Compressors
- 4.5 LNG / Forcing Vaporizer
- 4.6 Gas Heaters
- 4.7 Custody Transfer System

## **CHAPTER 5 CARGO HANDLING**

- 5.1 Loading operation - Initial voyage
- 5.2 Loading operation - Except initial voyage
- 5.3 Discharging operation

## **CHAPTER 6 SAFETY**

- 6.1 Liquefied gas fires and safety measures
- 6.2 Fire-fighting systems
- 6.3 Cargo hazards and medical treatment

## **BIBLIOGRAPHY**

## **ABSTRACT**

The present project relates to the handling of liquefied natural gas as cargo but also as fuel in marine transport. It refers to the various characteristics of the gas in liquid form, the way of transportation and analysis of the components of the vessel to convey that cargo. In addition, a separate chapter analyzes the facilities, machinery and systems on LNG vessels to maintain the cargo at the required temperatures and pressures under international regulations and to prepare the ship both during loading and discharging. Finally, reference is made to the risks that may occur during the process of loading or everyday actions related to the cargo and the ways to tackle the major problems threatening the health of workers in the liquefied natural gas carriers are analyzed.

~

# **CHAPTER 1 FUNDAMENTAL KNOWLEDGE ABOUT LNG**

## **1.1 Introduction**

A liquefied gas is the liquid form of a substance which, at ambient temperature and at atmospheric pressure, would be a gas. Natural gas is a mixture of hydrocarbons which, when liquefied, is usually transported and stored at a temperature very close to its boiling point at atmospheric pressure (approximately  $-160^{\circ}\text{C}$ ). LNG is a clear colourless, odourless liquid and at a very low temperature.

Most liquefied gases are hydrocarbons and the key property that makes hydrocarbons the world's primary energy source – combustibility – also makes them inherently hazardous. LNG does not burn itself but, needs to be in vapor form and mixed with air to burn. Is combustible in the range of 5% to 15% volume concentrations in air. Combustible mixtures in confined space will burn explosively. Because these gases are handled in large quantities, it is imperative that all practical steps are taken to minimize leakage and to limit all sources of ignition. Gases are always liquefied for transportation in bulk simply because more cargo can be fitted in a given volume. Typically, 1 volume of liquefied natural gas (LNG) is equivalent to 600 volumes of vapour. Natural gas is now a major commodity in the world energy market and approximately 100 million tonnes are carried each year by sea.

The actual composition of LNG will vary depending on its source and on the liquefaction process, but in all cases the major constituent will be methane with small percentages of the heavier hydrocarbons such as ethane, propane, butane and pentane. In addition, small quantities of nitrogen may be present. However, during a normal sea voyage, heat is transferred to the LNG cargo through the cargo tank insulation, causing vaporization of part of the cargo, i.e. boil-off. The composition of the LNG is



changed by this boil-off because the lighter components, having lower boiling points at atmospheric pressure, vaporize first. Therefore the discharged LNG has a lower percentage content of Nitrogen and Methane than the LNG as loaded, and a slightly higher percentage of Ethane, Propane and Butane, due to Methane and Nitrogen boiling off in preference of the heavier gases.

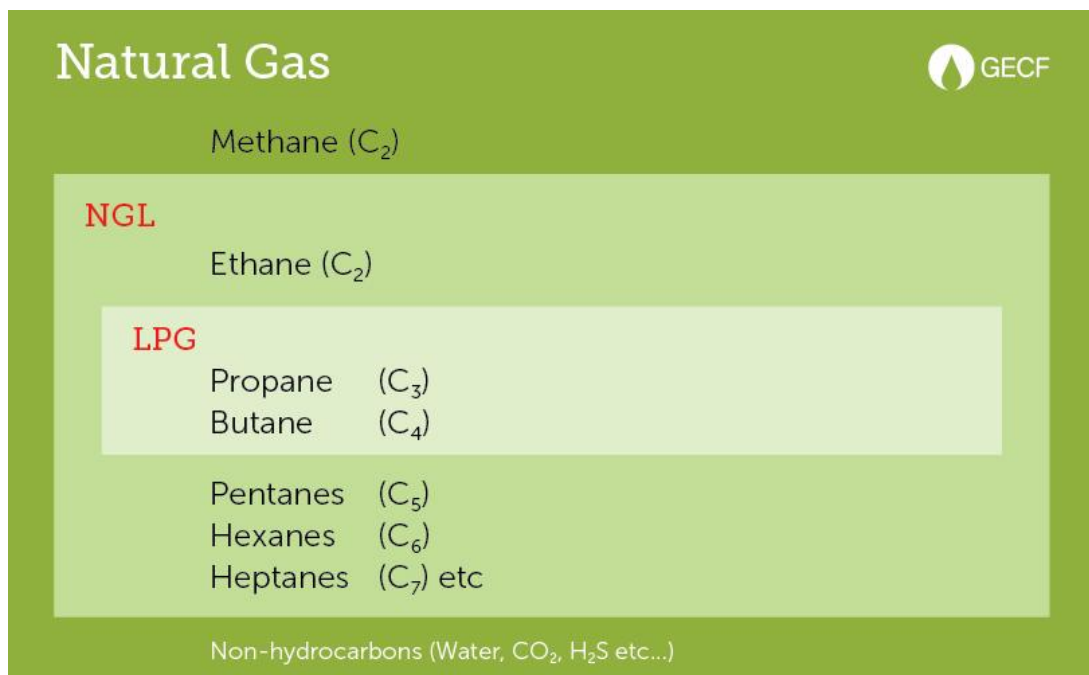

**Figure 1** Constituents of natural gas

## 1.2 LNG production

Natural gas may be found in:

- Underground wells, which are mainly gas bearing (non-associated gas)
- Condensate reservoirs (pentanes and heavier hydrocarbons)
- Large oil fields (associated gas)

Natural gas contains smaller quantities of heavier hydrocarbons (collectively known as natural gas liquids - NGLs). This is in addition to varying amounts of water, carbon dioxide, nitrogen and other non-hydrocarbon substances, as shown in Figure 1. The proportion of NGL contained in raw natural gas varies from one location to another. Methane (CH<sub>4</sub>) is by far the predominant constituent, ranging from 70 per cent to 99 per cent. However, NGL percentages are generally smaller in gas wells when compared with those found in condensate reservoirs or that associated with crude oil. Regardless of origin, natural gas requires treatment to remove heavier hydrocarbons and non-hydrocarbon constituents.

A liquefaction plant used to produce liquefied natural gas (LNG). The raw gas that feeds the plant is first stripped of condensates. This is followed by the removal of acid gases (carbon dioxide and hydrogen sulphide). Carbon dioxide must be removed as it freezes at a temperature above the atmospheric boiling point of LNG and the toxic compound hydrogen sulphide is removed as it causes atmospheric pollution when being burnt in a fuel. Acid gas removal saturates the gas stream with water vapour and this is then removed by the dehydration unit.

### **1.3 Use of Inert Gas and Nitrogen**

Inert gas is used on gas carrier to inert cargo tanks and to maintain positive pressures in hold and interbarrier spaces. This is carried out in order to prevent the formation of flammable mixtures. The inerting operation for cargo tanks is necessary prior to aerating for inspection or dry-dock and it's also required before moving from gas-free condition to loaded condition. Inert gas can be made by the combustion of low sulphur light diesel oil or by separating oxygen from air using “pressure swing absorption” with an absorbent carbon bed as a molecular sieve. The main



combustion products are carbon dioxide and water, and the nitrogen in air is unchanged.

The cargo tank inerting is started after lowering the dew point of the cargo tank atmosphere to about  $-40^{\circ}\text{C}$  by feeding dry air from the inert gas generator (IGG) into the cargo tanks. Inert gas (IG) is heavier than the dry air in the cargo tanks, therefore the IG should be led to the bottom of each cargo tank. The discharged mixture of dry air and IG is vented to the atmosphere via the forward vent mast. During cargo tank inerting operation the oxygen ( $\text{O}_2$ ) content shall be reduced to 2% or less by volume. The purging of dry air shall be carried out with IG by the "Piston effect" flow method utilizing the difference in specific gravity.

Instead of using IG for cargo tank inerting, alternatively, liquid nitrogen ( $\text{N}_2$ ) may be used for the same purpose. Nitrogen is the most common gas in nature since it represents 79% of the atmosphere volume. In the case cargo tanks are inerted utilizing liquid nitrogen, cargo tanks gassing up will not be required and vessel will be ready to start cargo tank cool down immediately upon completion of Nitrogen-inerting. Gassing up is not required because liquid nitrogen does not contain any humidity or carbon dioxide ( $\text{CO}_2$ ).

Nitrogen on the vessel is produced either by the nitrogen generators that separate air into nitrogen and oxygen based on a hollow fiber membrane principle, or by the vaporization of liquid nitrogen supplied from shore. The nitrogen is used on board for:

- Purging of cargo pipelines
- Purging the heaters
- Pressurization of the insulation spaces
- Sealing of the gas compressors
- Fire extinguishing in the vent masts

## CHAPTER 2 PROPERTIES OF LNG

### 2.1 Chemical structure of gases

As mentioned above, most of the gases are hydrocarbons which are substances whose molecules contain only hydrogen and carbon atoms. The molecules can be in various arrangements and the products may be gases, liquids or solids at ambient temperature and pressures, depending upon the number of the carbon atoms in the molecular structure. Generally, those hydrocarbons with up to four carbon atoms are gaseous at ambient conditions and comprise the liquefied gases. Methane ( $\text{CH}_4$ ), ethane ( $\text{C}_2\text{H}_6$ ), propane ( $\text{C}_3\text{H}_8$ ) and butane ( $\text{C}_4\text{H}_{10}$ ), which they form LNG, are all saturated hydrocarbons. This means that the hydrogen atom has only one bond and it can unite with only one other atom in opposition to the carbon atoms have four bonds and can unite with other carbon atoms or atoms of other elements.

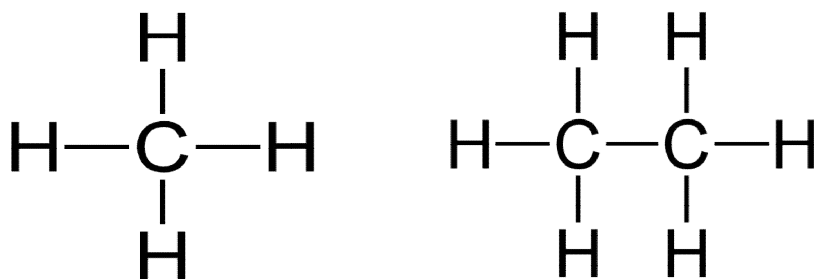

**Figure 2** Molecular structure of Methane and Butane

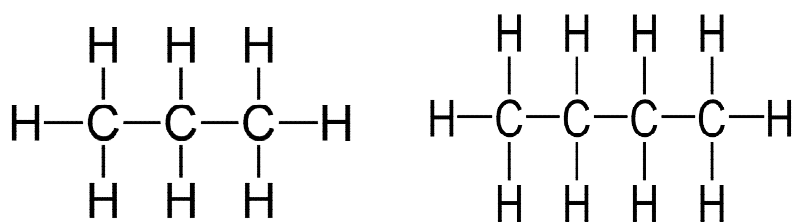

**Figure 3** Molecular structure of Propane and Butane

This saturated hydrocarbons are all colourless and odourless liquids. They all are flammable gases and will burn in air or oxygen to produce carbon dioxide and water vapour. They do not present chemical compatibility problems when in contact with the construction materials commonly encountered in gas handling. However, in the presence of moisture may form hydrates.

## **2.2 Physical properties and evaporation of LNG**

The physical properties of a liquefied gas depend on its molecular structure and they are similar to the water's. Some compounds have the same molecular formula, but the ways in which the atoms are arranged within the molecule may be different. These different compounds of the same basic substance are called isomers. They have the same molecular mass but different physical and chemical properties. Examples are n-butane and iso-butane.

The most important physical property of a liquefied gas is its saturated vapour pressure/temperature relationship. The average energy of the particles in a liquid is governed by this temperature. The higher the temperature, the higher the average energy. But, within that average, some particles have energies higher than the average and others have energies that are lower. Some of the more energetic particles on the surface of the liquid can be moving fast enough to escape from the attractive forces holding the liquid together. This means they will evaporate.

Evaporation only takes place on the surface of the liquid. This is quite different from boiling, which happens when there is enough energy to disturb the attractive forces throughout the liquid, i.e. at boiling water there are bubbles of gas being formed all the way through the liquid. Instead, at water evaporating in the sun, there

are no bubbles because water molecules are simply breaking away from the surface layer. Eventually, the water will all evaporate in this way. The energy lost as the particles evaporate is replaced from the surroundings. As the molecules in the water jostle with each other, new molecules will gain enough energy to escape from the surface.

In LNG carriers the liquid is in the tanks. Common sense says that the liquid in a tank (at this example the water in a sealed bottle) doesn't seem to evaporate or it doesn't disappear over time. But there is constant evaporation from the surface. Particles continue to break away from the surface of the liquid, but this time they are trapped in the space above the liquid. As the gaseous particles bounced around some of them will hit the surface of the liquid again and be trapped there. There will rapidly be an equilibrium set up in which the number of particles leaving the surface is exactly balanced by the number rejoining it. In this equilibrium, will be a fixed number of the gaseous particles in the space above the liquid.

When these particles hit the walls of the tank, they exert a pressure which is called saturated vapour pressure of the liquid. A high vapour pressure means that the liquid must be volatile. Molecules escape from its surface relatively easily and aren't very good at sticking back on again. As a result larger numbers of them appears in the gas state once equilibrium is reached. When the temperature increased, then the average energy of the particles also increases. This means that more of them are likely to have enough energy to escape from the surface of the liquid, which will tend to increase the saturated vapour pressure.

## **2.3 Liquid/vapour densities and rollover effect**

### **Liquid density**

The density of a liquid is defined as its mass per unit and is measured in kilogrammes per cubic meters ( $\text{kg/m}^3$ ). The liquid density decreases with increasing temperature. The large changes seen are due to the comparatively large coefficient of volumetric expansion of liquefied gases. All the liquefied gases, with exception of the chlorine, have liquid relative densities lower than one. This means that in the event of a spillage onto water, these liquids would float prior to evaporation.

### **Vapour density**

The density of vapour is also quoted in unit of kilogrammes per cubic meter ( $\text{kg/m}^3$ ). The density of the saturated vapour increases with increasing temperature. This is because the vapour is in contact with its liquid and, as the temperature rises, more liquid transfers into the vapour-phase in order to achieve the higher vapour pressure. This results in a considerable increase in mass per unit volume of the vapour space. Most of the liquefied gases produce vapours which are heavier than air. The exceptions are methane (at temperatures greater than  $-113^\circ\text{C}$ ), ethylene and ammonia. Vapours raises to the atmosphere, which are denser than air, tend to seek lower ground and do not disperse readily.

### **Rollover**

A phenomenon known as “rollover” can cause a loss of containment and lead to the formation of LNG liquid pools. Caused by stratification within a storage tank, LNG “rollover” refers to a rapid release of LNG vapours from a tank. When two

separate layers of different densities (as a result of different LNG compositions) exist in a tank, the possibility of rollover arises.

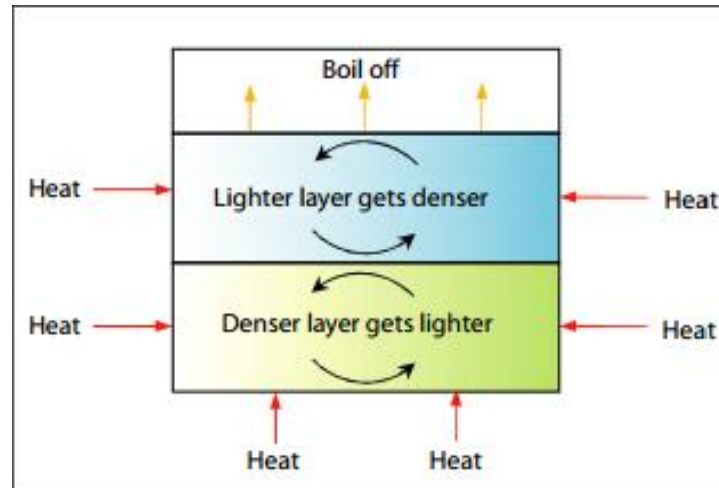

**Figure 4** Rollover effect

The mechanism behind “rollover” is that basically, in the top layer, the liquid becomes warmer as a result of heat leaking into the tank and rises up to the surface, where it then evaporates. As the lighter gases are preferentially evaporated, the liquid in the upper layer becomes denser. In the bottom layer, the warmed liquid rises towards the interface by free convection but does not evaporate due to the hydrostatic head exerted by the top layer. In this way, the lower layer becomes warmer and less dense. The two layers mix rapidly, as the densities of two layers approach each other. The lower layer (which has been superheated) gives off large amounts of vapour as it rises to the surface of the tank. This phenomenon is termed “rollover”. A rapid release of large quantities of vapour, leading to potentially hazardous situations is the greatest risk arising from a rollover accident.

In addition, the tank pressure relief system may not be able to handle the rapid boil off rates, which could result in tank failure, leading to the rapid release of large

amounts of liquid LNG then forming into a liquid pool. Rollover can be effectively avoided by carefully monitoring the composition of all LNG streams added to the tanks, and by keeping the tank contents well-mixed using mechanical means such as pumps to circulate the liquid. It should also be noted that the phenomenon of rollover only happens rarely, and typically only if two different cargos have been loaded together in the same tank. Stratification can also be prevented by measuring the density of the cargo while unloading an LNG vessel and, if necessary, adjusting the unloading procedures accordingly. Additionally, the LNG storage tanks have rollover protection systems which include pump-around mixing systems and distributed temperature sensors.

## **2.4 Flammability**

The most hazardous aspect of liquefied gases is the flammable nature of their vapours. Much effort is put into ship design to ensure effective cargo containment so as to limit vapours escaping to atmosphere. All liquefied gases transported in bulk by the sea, with exception of chlorine, are flammable. The vapours of other liquefied gases are easily ignited. Natural gas burns with a visible flame and has narrow flammability limits, combusting only in air-to-fuel proportions of 5-15%. Below 5% the mix is too lean to burn and above 15% the mix is too rich to burn. Pools of liquefied natural gas do not ignite as readily as pools of gasoline or diesel fuel. The auto-ignition temperature of methane is 540°C, significantly higher than gasoline (257°C) or diesel (316°C). So while open flames and sparks can ignite natural gas, many hot surfaces such as a car muffler will not. Methane vapors in open air exhibit a very slow flame speed of about 4 miles per hour.



## **Flammability of Methane, Oxygen and Nitrogen Mixtures**

The ship must be operated in such a way that a flammable mixture of methane and air is avoided at all times. The relationship between gas/air composition and flammability for all possible mixtures of methane, air and nitrogen is shown in the diagram.

The vertical axis A-B represents oxygen-nitrogen mixtures with no methane present, ranging from 0 % oxygen (100 % nitrogen) at point A, to 21 % oxygen (79 % nitrogen) at point B. The latter point represents the composition of atmospheric air.

The horizontal axis A-C represents methane-nitrogen mixtures with no oxygen present, ranging from 0 % methane (100 % nitrogen) at point A, to 100 % methane (0 % nitrogen) at point C. Any single point in the diagram within the triangle ABC represents a mixture of all three components, methane, oxygen and nitrogen, each present in a specific proportion of the total volume. The proportions of the three components represented by a single point can be read off the diagram.

For example, at point D:

Methane: 6.0 % (read on axis A-C)

Oxygen: 12.2 % (read on axis A-B)

Nitrogen: 81.8 % (remainder)

The diagram consists of three major sectors:

- 1) The Flammable Zone Area EDF: Any mixture the composition of which is represented by a point that lies within this area is flammable.
- 2) Area HDFC: Any mixture the composition of which is represented by a point that

lies within this area is capable of forming a flammable mixture when mixed with air, but contains too much methane to ignite.

3) Area ABEDH: Any mixture the composition of which is represented by a point that lies within this area is not capable of forming a flammable mixture when mixed with air

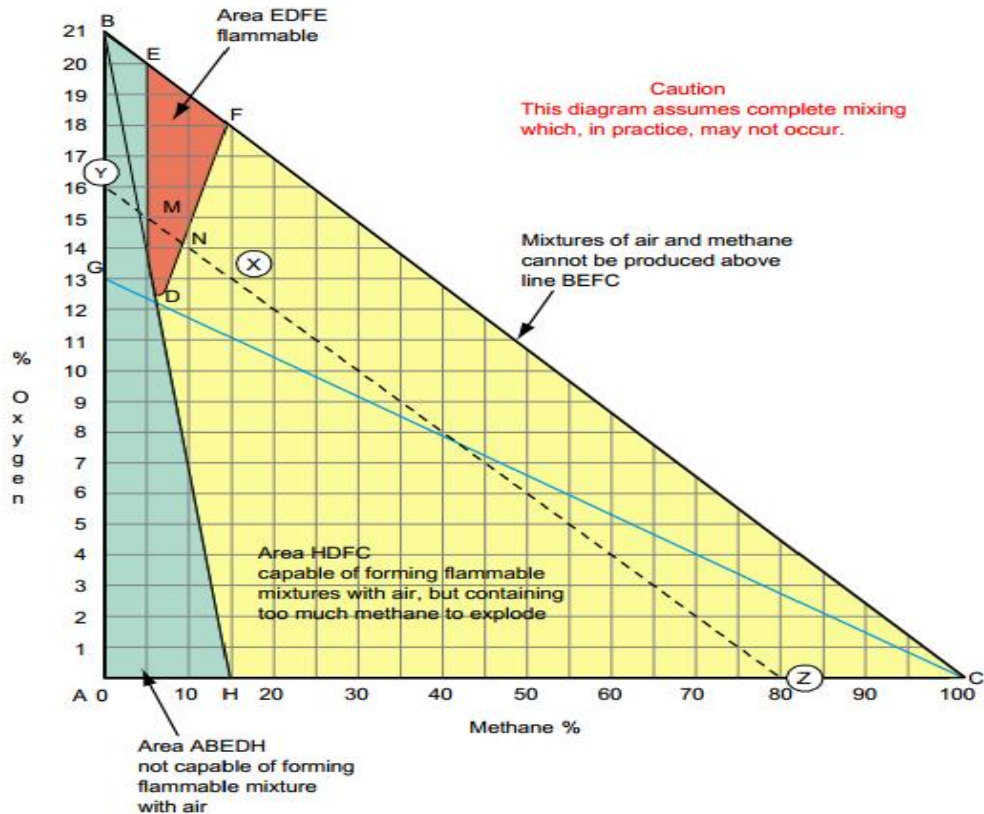

**Figure 5** Flammability limits

### Combustion

Combustion is a chemical reaction, initiated by a source of ignition, in which a flammable vapour combines with oxygen to produce carbon dioxide, water vapour and heat. Under certain circumstances when oxygen supply to the fuel is restricted, carbon monoxide or carbon can also be produced. The three requirements for combustion to take place are fuel, oxygen and source of ignition. Furthermore, for ignition to occur, the proportions of vapour to oxygen (or to air) must be within the product's flammable limits.

The gases produced by combustion are heated by the reaction, In open spaces, gas expansion is restricted and combustion may proceed without undue over-pressures developing. If the expansion of the hot gases is restricted in any way, pressures will rise and the speed of flame travel will increase. This depends upon the degree of confinement encountered. Increased flame speed gives rise to a more rapid increase in pressure with the result that damaging over-pressures may be produced. Even in the open, if the confinement resulting from surrounding pipe work, plant and buildings is sufficient, the combustion can take on the nature of an explosion. In severely confined conditions, such as within a building or ship's tank, where the expanding gases cannot escape, the internal pressure and its rate of increase may be sufficient to burst the containment. Here, the explosion is not due to high combustion rates and flame speed: it results more from the surge of high pressure upon containment rupture.

### **Flammable Range**

The flammable range gives a measure of the proportions of flammable vapour to air for combustion to occur, in other words is the range between the minimum and maximum concentrations of vapour (per cent by volume) in air which form a flammable mixture. The lower and upper limits are usually abbreviated to LFL (lower flammable limit) and UFL (upper flammable limit).

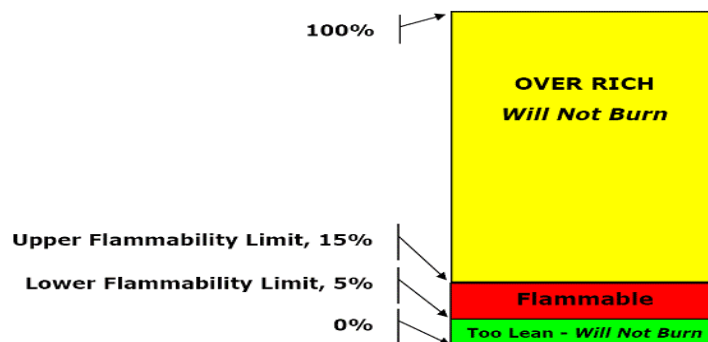

**Figure 6** Flammable range for Methane

All the liquefied gases, with the exception of chlorine, are flammable but the limits of the flammable range vary depending on the particular vapour. The flammable range of a vapour is broadened in the presence of oxygen in excess of that normally found in air. In such cases the LFL is changed little but the UFL is considerably raised. All flammable vapours exhibit this property and, as a result, oxygen should not normally be introduced into an atmosphere where flammable vapours exist.

### **Flash Point**

The flash point of a liquid is the lowest temperature at which that liquid will evolve sufficient vapour to form a flammable mixture with air. High vapour pressure liquids such as liquefied gases have extremely low flash points.

### **Auto-Ignition Temperature**

The auto-ignition temperature of a substance is the temperature to which its vapour-in-air mixture must be heated to ignite spontaneously. The auto-ignition temperature is not related to the vapour pressure or to the flash point of the substance and, since the most likely ignition sources are external flames or sparks, it is the flash point which is used for the flammability classification of hazardous materials.

### **Energy required for ignition**

Accidental sources of ignition of a flammable vapour can be flames, thermal sparks and electric arcs or sparks. The minimum ignition energy necessary to set fire to hydrocarbon vapours is very low, particularly when the vapour concentration is in the middle of the flammable range. Minimum ignition energies for flammable vapours are typically less than one millijoule (mJ).

## Flammability within Vapour Clouds

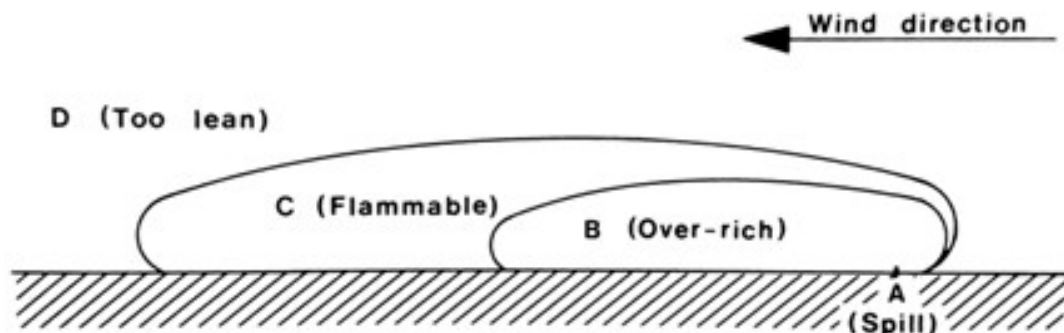

**Figure 7** Flammable vapour zones

If a liquefied gas spilled in an open space, the liquid will rapidly evaporate to produce a vapour cloud which will gradually disperse downwind. The region (B) immediately adjacent to the spill area (A) is non-flammable because it is over-rich. It contains a too low percentage of oxygen to be flammable. Region (D) is also non-flammable because it is too lean; containing too little vapour to be flammable. The flammable zone lies between these two regions as indicated by (C).

## **2.5 Spillage of LNG**

When LNG is spilled from a tank onto water, it forms a pool of liquid on the water. Then, a Liquefied gas fires and Fire-fighting systems fog like vapour cloud forms close to the water as the liquid warms and changes into natural gas vapour. Ambient air mixes with the cloud as it continues to warm up, and eventually the natural gas vapour disperses into the atmosphere. This cloud could however drift into populated

areas before completely dispersing under certain atmospheric conditions depending on the conditions, LNG vapours are flammable. If the LNG vapour cloud ignites, the resulting fire, depending on available oxygen, will be burnt back through the vapour cloud toward the initial spill. It will continue to burn above the LNG that has pooled on the surface resulting in what is known as a pool fire.

Experimental data for small scale LNG fires have shown that LNG fires burn hotter than oil fires of the same size. Both the high temperatures of an LNG fire and the cold temperatures of the spilled LNG, have the potential to seriously damage the tanker and result in a cascading failure of the vessel. A cascading failure could also greatly escalate the severity of the original incident.

Let's take an example of the escape of a fully refrigerated liquid from its containment. Here the liquid is already at or near atmospheric pressure but, on escape, it is brought immediately into contact with the ground or sea at ambient temperature. The temperature differences between the cold liquid and the material it contacts, provides an immediate heat transfer into the liquid and as a result we have rapid evolution of vapour. For spills on the sea surface, the strong convection currents in the water may maintain the initial temperature difference and evaporation will probably continue at the initial rate. In this case, the large quantities of cold vapour produced from the liquid will diffuse into the atmosphere and cause condensation of the water vapour in the air. By this process, a visible vapour cloud is formed which is white in colour.

## **CHAPTER 3 DESIGN PRINCIPLES AND TYPE OF SHIPS**

### **3.1 History of ships carrying liquefied gases**

In the mid 1950s, an early concept for the transportation and use of LNG was explored, by Union Stockyards, Chicago and Continental Oil through a joint venture named Constock. The plan was to buy gas on the Gulf Coast, liquefy it, transport it by water to Chicago, and vaporize it in the food processing industry, using the cold for refrigeration and making the gas available for industrial use. As part of this venture a barge, the "Methane" with a cargo capacity of 5,550 m<sup>3</sup>, was built at Ingalls Shipyard to operate on the Mississippi hauling LNG north to Chicago. The initial economics looked good, however the FDA (Food & Drug Administration) refused to permit the concept down due to the fear of contaminating the food product. The failure to obtain approval from FDA caused Union Stockyards to withdraw from the venture.

Continental chose to continue the LNG operation and found that gas could be liquefied on the Gulf coast, transported to the east Coast by water, vaporized and put into the gas mains competitively with pipelining. In the late 1950's an opportunity to sell LNG to the UK was developed and Constock aligned itself with the British Gas Council to develop the world's first ocean shipping system for LNG.

In January 25<sup>th</sup> 1959, the world's first LNG tanker, The Methane Pioneer, a converted World War II liberty freighter built in 1945 and originally called the Marline Hitch, carried 5,000 m<sup>3</sup> of LNG in five aluminum prismatic tanks with balsa wood supports and insulation of plywood and urethane from Lake Charles Louisiana to Canvey Island in the Thames estuary. She took a total of 8 cargos of LNG from Lake Charles to Canvey Island, the last being in March 1960. The Methane Pioneer became the first diesel powered LNG ship and the first to offload at sea and was



followed by the carriers "Methane Princess" and "Methane Progress" (each of a capacity of 27,400m<sup>3</sup>) which had their first passage in February 1962. "Methane Princess" "retired" in 1997 after 27 years of use, not due to the state of the carrier but due to the fact that using such an old carrier is not cost-effective.



**Image 1** Methane Pioneer

The first commercial contract for the import of LNG into Japan was signed in 1967 and after that, Japan became the leading power in LNG import. Until this day, Japan remains the biggest importer with a total import of one third of the world's LNG.

After the first carriers, new research was done which led to the general division of LNG carriers into two large groups. Membrane ships (created during the cooperation and afterwards the union of two French factories "Technigaz" and Gas Transport into the corporation GTT) and spherical LNG carriers (Kvaerner – Moss). From mid 1970s the size of the LNG carriers was standardized to 125.000 m<sup>3</sup> to 138.000 m<sup>3</sup>. Until 2000, the number of LNG carriers was relatively constant, around 120 ships. After that, there was a great boom and expansion in LNG carriers and today, over 460 LNG carriers are sailing in the world. The size and the capacity have also increased and today, Q-max (260000 m<sup>3</sup>) and Q-flex (215000m<sup>3</sup>) are in use.



**Figure 8** Sizes of LNG ships

### 3.2 Type of ships

There is much variation in the design, construction and operation of gas carriers due to the variety of cargos carried and the number of cargo containment systems utilised. Cargo containment systems may be of the independent tanks (pressurised, semi-pressurised or fully refrigerated) or of the membrane type. Some of the principal features of these design variations and a short history of each trade are described below.

#### **Fully pressurised ships**

These are generally the smallest type of liquefied gas carrier afloat (up to about 5,000 m<sup>3</sup>, although some are larger) and carry products at ambient temperatures in cylindrical or spherical steel pressure vessels designed to withstand pressures up to 20 bar. They are not fitted with reliquefaction plant and represent a simple cost- effective

means of transporting LPGs and chemical gases to the smaller gas terminals. These ships carry the cargo in spherical or cylindrical steel tanks, designed for a working pressure of  $17.5 \text{ kg/cm}^2$ . This corresponds to the vapour pressure of propane at  $45^\circ\text{C}$ , which is the maximum ambient temperature in which the ship is likely to operate. No means of temperature or pressure control is necessary.

### **Semi-pressurised ships**

Semi-pressurised ships are similar to fully pressurised ships and they are designed typically for a maximum working pressure of 5-7 bar. This type of gas carrier has evolved as the optimum means of transporting a wide variety of gases such as LPG (Liquefied Petroleum Gas), vinyl chloride, propylene and butadiene. The cargo capacities can vary from  $3.000$  to  $20.000 \text{ m}^3$  and the tanks are usually made from low-temperature steel to provide carriage temperatures of  $-48 \text{ }^\circ\text{C}$  which temperature is suitable for most LPG and chemical gas cargos.

### **Ethylene ships**

Ethylene carriers are a special type of gas carrier that can transport ethylene fully-refrigerated at its atmospheric pressure and boiling point of  $-104^\circ\text{C}$ . Such ships are often built for specific trades. Many ethylene carriers can also carry LPG cargos, which increases their flexibility. Cargo capacity depends on the trade for which the vessel was constructed and range from  $1,500$  -  $15,000 \text{ m}^3$ .

### **Fully refrigerated ships**

Fully refrigerated tankers are built to carry liquefied gases at low temperature and atmospheric pressure between terminals equipped with fully refrigerated storage tanks. The tankers have prismatic-shaped cargo tanks fabricated from 3.5% nickel steel, allowing the carriage of cargos at temperatures as low as  $-48^{\circ}\text{C}$ , marginally below the boiling point of pure propane. Prismatic tanks enabled the ship's cargo carrying capacity to be maximized, thus making fully refrigerated ships highly suitable for carrying large volumes of cargo such as LPG, ammonia and vinyl chloride over long distances. The self-supporting prismatic shape of the cargo tanks allows a better utilization of the available hold space than the type of ships described previously. The tanks are usually designed for a maximum working pressure of about 280 mbar and a minimum working temperature of  $-50^{\circ}\text{C}$  making them suitable for the carriage of butane, butadiene, ammonia, propane and propylene.

### **LNG ships**

LNG carriers are specialised ships transporting LNG, at its atmospheric pressure and boiling point of approximately  $-162^{\circ}\text{C}$ , depending on the cargo grade. These ships are usually dedicated vessels, but some smaller examples may also carry basic LPG cargos. The majority of LNG carriers are between 125,000 and 135,000  $\text{m}^3$  in capacity.

## **3.3 Cargo containment systems, type of tanks and membranes**

A cargo containment system is the total arrangement for containing cargo including, where fitted:

- A primary barrier (the cargo tank),
- Secondary barrier (if fitted),
- Associated thermal insulation,
- Any intervening spaces, and
- Adjacent structure, if necessary, for the support of these elements.

For cargoes carried at temperatures between  $-10^{\circ}\text{C}$  and  $-55^{\circ}\text{C}$  the ship's hull may act as the secondary barrier and in such cases it may be a boundary of the hold space.

### **Independent tanks**

Independent tanks are completely self-supporting and do not form part of the ship's hull structure. Moreover, they do not contribute to the hull strength of a ship. As defined in the IGC Code, and depending mainly on the design pressure, there are three different types of independent tanks for gas carriers: these are known as Types 'A', 'B' and 'C'. Of these three categories, on LNG carriers, only type 'B' is used.

### **Type 'B' tanks / Kværner-Moss Type**

The most common arrangement of Type 'B' tank is a spherical tank. This tank is of the Kværner-Moss design. Because of the enhanced design factors, Type 'B' tank requires only a partial secondary barrier in the form of a drip tray. The hold space in this design is normally filled with dry inert gas. However, when adopting modern practice, it may be filled with dry air provided that inerting the space can be achieved if the vapour detection system shows cargo leakage. A protective steel dome covers the primary barrier above deck level and insulation is applied to the outside of the tank.

The Type 'B' spherical tank is almost exclusively applied to LNG ships; seldom featuring in the LPG trade. A Type 'B' tank, however, need not be spherical. There are Type 'B' tanks of prismatic shape in LNG service. The prismatic Type 'B' tank has the benefit of maximising ship hull volumetric efficiency and having the entire cargo tank placed beneath the main deck. Where the prismatic shape is used, the maximum design vapour space pressure is limited to 0.7 bar.

The cargo tank will be constructed of an aluminum alloy. The sphere will be supported by a cylindrical skirt (~17cm thick) at the equatorial ring. This fitting allows the sphere to expand and contract freely. All piping, cabling and pumping will be secured within the tabular tower at the centre of the tank. The tanks are designed to operate at 2 bar pressure, so that they can be unloaded by pressurizing the tank in case of failure of both cargo pumps.

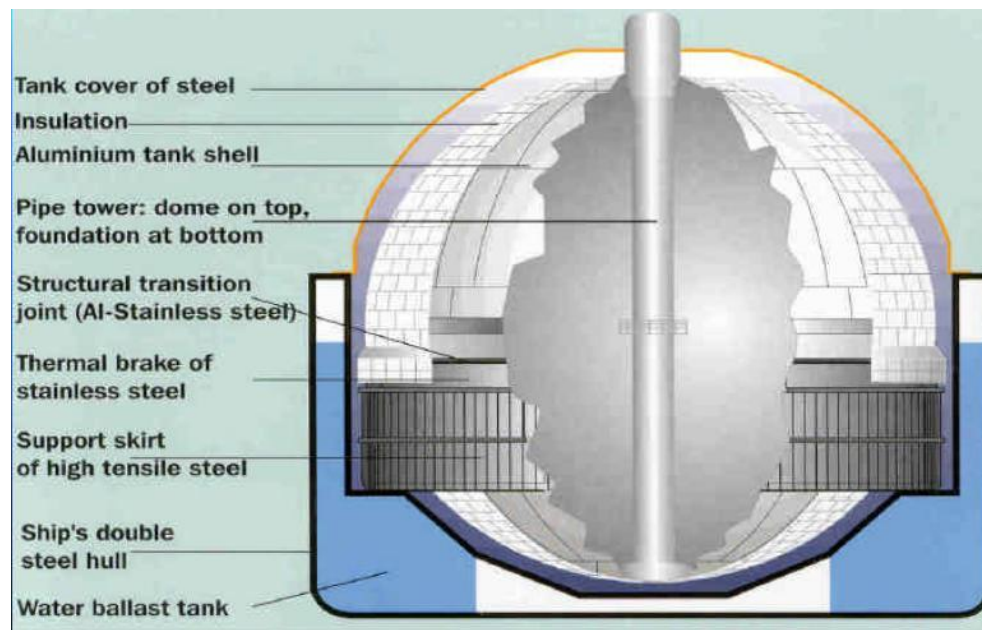

**Figure 9** Kvaerner-Moss type



**Image 2** Inside a Kvaerner-Moss tank

### **Membrane tanks**

The concept of the membrane containment system is based on a very thin primary barrier (membrane – 0.7 to 1.5 mm thick) which is supported through the insulation. Such tanks are not self-supporting like the independent tanks. An inner hull forms the load bearing structure. The membrane system is based on a very thin metallic layer (membrane). This inner (or primary) membrane is supported by inner insulation layer. In addition, a secondary barrier and insulation layer is necessary to ensure the integrity of the whole system. The IGC Code states that the secondary barrier must be capable of containing a tank leakage for period of 15 days. The membrane containment system is the most popular in use today and is used on approximately 70% of the ships in service.

The membrane is designed in such a way that thermal expansion or contraction is compensated without over-stressing the membrane itself. There are two principal types of membrane system in common use, both named after the companies who developed them and both designed primarily for the carriage of LNG.



## Gaz Transport membrane system / GTT No96

The first Gaz Transport system was introduced in 1973. The primary barrier is an Invar membrane that is 0.7 mm thick and 500 mm wide. The insulation for the primary layer is constructed of 200-300 mm thick plywood boxes filled with loose granular perlite which is mixed with silicone to make it impervious to water or moisture. This construction allows them to withstand high impact pressures and absorb the energy from liquid motion when loading, discharging or cargo sloshing at sea. The secondary barrier and insulation layer is identical to the primary and offers 100% back-up. The insulation spaces are inerted with nitrogen ( $N_2$ ).

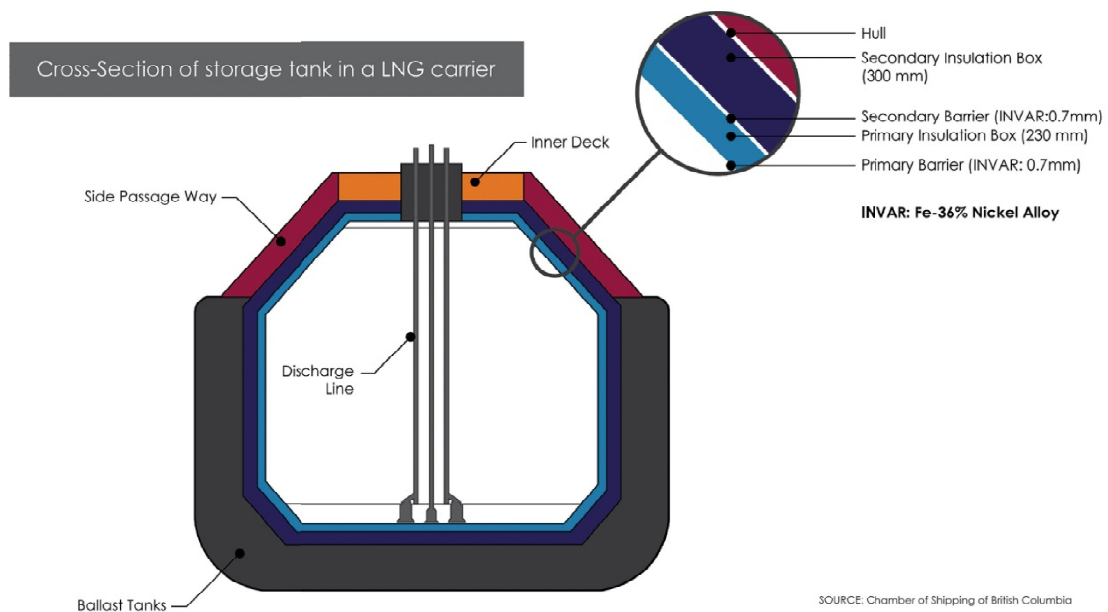

**Figure 10** GTT No96 membrane system



**Image 3** Inside a GTT No96 tank

### **Technigaz membrane system / MARK III**

The MARK III Technigaz system was developed to achieve a lower cargo boil-off ratio that was offered by the existing MARK I system, which was introduced in 1969. The Technigaz system features a primary barrier of stainless steel (1.2 mm in thickness) having raised corrugations, or waffles, to allow expansion and contraction. The insulation that supports the primary membrane consisted of reinforced cellular foam and within the foam there is a fiberglass cloth/aluminum laminate acting as secondary barrier (i.e. Triplex layer). Typical membrane tanks have a filling limit of 98%.

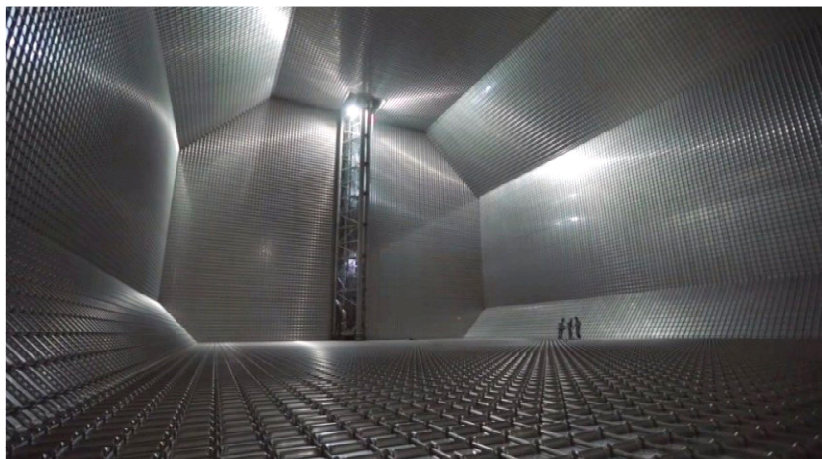

**Image 4** Inside MARK III tank

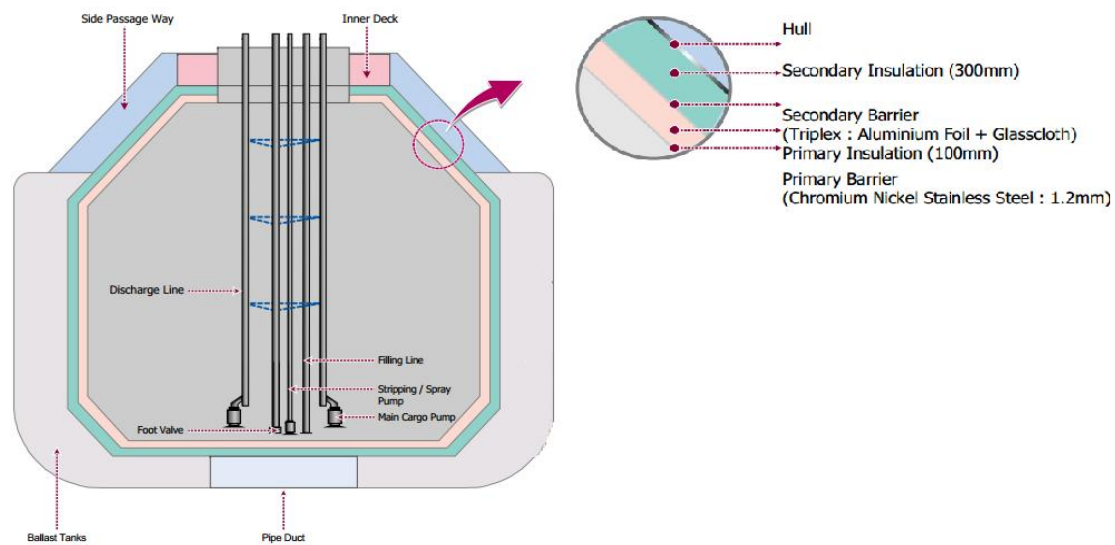

**Figure 11** MARK III membrane tank

### 3.4 Cofferdams and Glycol system

The cargo containment and handling systems must be completely separate from spaces such as the accommodation and machinery spaces by use of a cofferdam or another means of gastight segregation. On membrane ships, there is a cofferdam between each cargo tank. This is so, because there are transverse bulkheads at the end of each tank which can be used to support the insulation and membrane tank.

However, unless there is a method of heating these transverse bulkheads, they would approach the temperature of the cargo when the LNG tanks on either side are cold and loaded. As a result, cofferdams are used as means of providing a series of bearing transverse bulkheads in the cargo area as well as providing a void between the bulkheads that can be heated.

The glycol water heating system for the cofferdams located in the cargo electric room. The system heats a glycol/water mix (55% water - 45% glycol), which is pumped around the cofferdam system to maintain the temperature inside those spaces,

when loaded, at approximately +5°C. Any failure of the cofferdam heating system with cargo on board must be treated as serious and repairs must be effected immediately. Glycol water is circulated through the system of heaters (electric or steam) by means of a circulating pump (one in use and the other on standby). Expansion within the system is allowed by an expansion tank to which topping up or filling can also be achieved. The required glycol water make-up is made by a pneumatic pump taking suction from a mixing tank. Reserve glycol from a header tank which is running down and mixed with the fresh water prior to being fed into the expansion tank.

### **3.5 Gas carrier layout**

Gas carriers have many features which are not found on other types of tanker. It is neither permitted for a cargo pump room to be placed below the upper deck, nor cargo pipelines be run beneath deck level; therefore, deepwell or submersible pumps must be used for cargo discharge. Pipelines to cargo tanks must be taken through a cargo tank dome which penetrates the deck. Where ships are fitted with a reliquefaction plant, this is located in a compressor room on deck. Adjacent to the compressor room is an electric motor room which contains the machinery for driving the reliquefaction compressors. The electric motor room and compressor room must be separated by a gastight bulkhead.

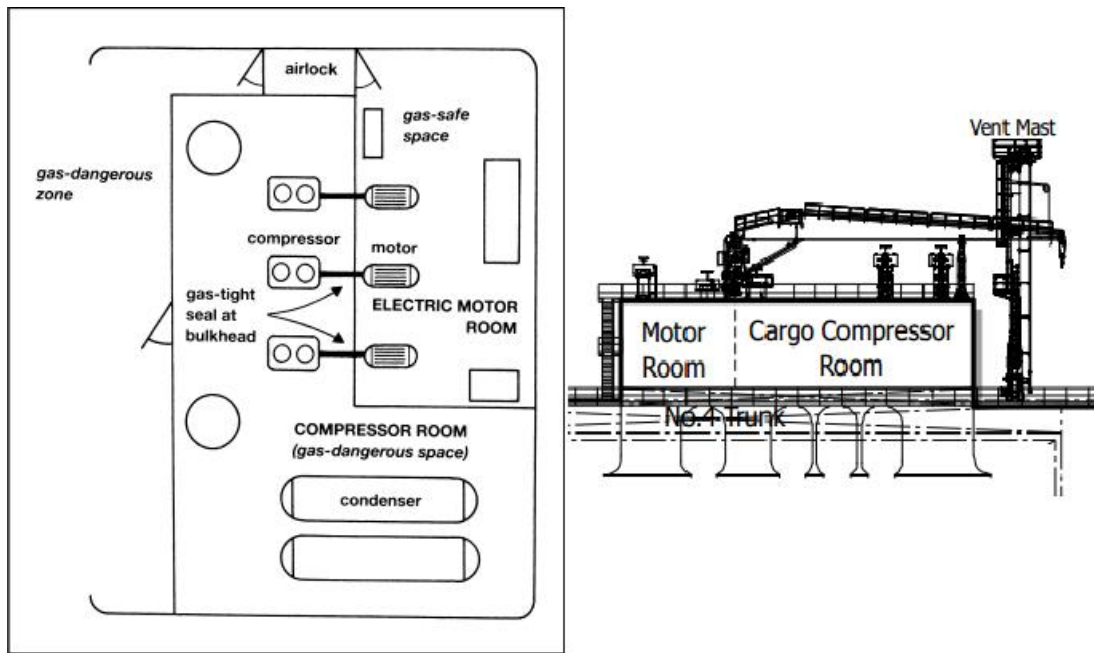

**Figure 12** Compressor & Motor Room on an LNG/C

The Gas Codes details the requirements for mechanical ventilation of these rooms. Positive pressure ventilation must be provided for the electric motor room and negative pressure ventilation for the cargo compressor area. This ensures an appropriate pressure differential between the rooms. An airlock entrance to the electric motor room from the ship's deck, with two gastight doors at least 1.5 meters apart, prevents loss of air pressure on entry. To ensure that both doors are not opened simultaneously they must be self-closing with audible and visual alarms on both sides of the airlock. (However an airlock is required only where access to the motor room is within 2.4 meters of the ship's main deck). In addition, loss of over-pressure in the motor room should trip the electric motors within. Another safety feature associated with the compressor room area concerns the sealing of the drive-shafts penetrating the gas-tight bulkhead between the compressor and motor room.

## **CHAPTER 4 SHIP'S EQUIPMENT AND SYSTEMS**

### **4.1 Cargo pipelines and valves**

#### **Liquid Main Line**

The system comprises of butt welded, cryogenic stainless steel pipeline connecting each of the four cargo tanks to the loading/discharge manifolds at the ship's side by means of a common line. At each tank liquid dome there is a manifold which connects to the loading and discharge lines from the tank to allow for the loading and discharge of cargo. This manifold on the liquid dome connects to the tank discharge lines from the port and starboard cargo pumps, the loading line, emergency pump well and spray line. At certain points along the liquid line, blank flanges and sample points are fitted to facilitate inerting and aeration of the system during refit. All sections of the liquid line outside the cargo tanks are insulated and covered with a moulded GRP (glass-fiber reinforced plastic) cover to act as a tough water and vapour tight barrier.

#### **Vapour Main Line**

The vapour line comprised of cryogenic stainless steel pipeline connecting each of the cargo tanks by means of a common line to the vapour manifold, the compressor room and the forward vent mast. The line to the compressor room allows the vapour to be used in the following procedures:

- Sent ashore during cargo loading by means of the HD (High Duty) compressors in order to control pressure in the cargo tanks.

- During voyages, the boil-off gas is sent to the engine room via the LD (Low Duty) compressor and heater, to use as fuel in the boilers.
- During repair periods, the gas may be vaporised and used to purge-dry the cargo tanks, if required.
- The line to the forward riser acts as a safety valve to all tanks and is used to control the tank pressure during normal operations.

The line to the forward vent mast acts as a safety valve to all tanks and is used to control the tank pressure during normal operations. At certain points along the vapour line, blank flanges and sample points are fitted to facilitate inerting and aeration of the system during refit. All sections of the vapour line outside the cargo tanks are insulated and covered with a moulded GRP cover to act as a tough water and vapour tight barrier.

### **Spray Main Line**

The spray line comprised of cryogenic stainless steel pipeline connecting the spray pump in each tank to the stripping/spray header (line) and serves the following functions by supplying LNG to:

1. The spray rails in each tank, used for cooldown and gas generation.
2. The main liquid line, used for cooling down lines prior to cargo operations.
3. Priming of discharge lines in the cargo tanks to prevent line surge when starting cargo pumps.
4. Supply of LNG to the vapourisers for gas generation to the compressors and heaters.

All sections of the spray line outside the cargo tanks are insulated and covered with a moulded GRP cover to act as a tough water and vapour tight barrier. At certain points along the vapour line, blank flanges and sample points are fitted to facilitate inerting and aeration of the system during refit.

### **Fuel Gas Line**

During transportation of LNG at sea, gas vapour is produced due to the transfer of heat from the outside sea and air through the tank insulation. In addition, energy is absorbed from the cargo motion due to the vessel's movement. Under normal power conditions, the boil-off is used as fuel in the ship's main generator engines. While, in many vessels, no fuel gas pump is installed inside each tank and if the ship's main generator engines require more fuel gas than a natural boil-off gas, then the spray line can be used as a fuel gas line.

### **Emergency Vent Line (Gas Main Line)**

The system comprises sections of pipeline which can be connected to the vapour line and the forward vent mast for use when "One Tank Operation" is required. The use of this line enables a single tank to be isolated and repair work carried out without having to warm up and inert the whole vessel.

### **Vent Line**

During normal operations, the pressure in the tanks is controlled by the use of the boil-off gas in the boilers as fuel, or controlled via the forward vent mast and the common vapour line. Each cargo tank is also fitted with an independent means of venting, comprising of two lines exiting the tank top into their own pilot operated



relief valve. From there the gas passes through a line into a vent mast where it is vented to atmosphere.

All vent masts are protected by the N<sub>2</sub> purge and fire smothering system. At certain points along the vent line, sample points are fitted to facilitate inerting and aeration of the system during refit. Sections of the vent line outside the cargo tanks are insulated with a rigid polyurethane foam covered with a molded GRP cover to act as a tough water and vapour tight barrier.

### **Inerting/Aeration Lines**

The system supplies inert gas or dry air to the cargo tanks and pipelines for inerting and drying during refit periods. The inert gas or dry air is supplied from the inert gas generator situated in the engine room. The line is connected to the gas main and the liquid main by means of a spool piece. By selective use of the spool pieces and the use of flexible hoses it is possible to inert/aerate all or just a single cargo tank. The cargo machinery room lines and the vapour return line can also be purged with inert gas or air by means of a spool piece and isolation valve on the line leading to this space. There is also means to inert to the compressor room via its own IG supply line with an isolation valve and spool piece.

## **4.2 Cargo pumps**

Cargo pumps fitted on board refrigerated gas carriers are normally of centrifugal design and may be either of the deepwell or submerged type. They may operate alone or in parallel with one another. Usually, the cargo tanks are fitted with two main cargo

pumps. Submerged pumps are used on LNG carriers and deepwell are used mostly on LPG carriers.

### **Submerged pumps**

These pumps are vertical single-stage centrifugal pumps with one inducer stage and driven by electric motors. The motor windings are cooled by the pumped LNG which also serves to lubricate and cool the pump and motor bearings. As the liquid cargo serves both lubricant and coolant, it is critically important that the pumps are never allowed to run dry, even for short periods. The pump assembly and electric motor are installed in the bottom of the cargo tank and power is supplied to the pump motor through copper or stainless steel sheathed cables, which terminate in a junction box at the cargo tank dome. If the pump were to be mounted on deck, this would need to be of a much larger capacity to draw the liquid up and would require a substantial cooling arrangement.

### **Design features**

Usually, each main cargo pump is typically rated to discharge at 145 m head of LNG at a typical flow rate of 1.500 m<sup>3</sup>/hr. For optimum discharge results, bulk discharge is often carried out with 8 pumps running in parallel. The pumps should be designed with inducers and bell mouths to give minimum Net Positive Suction Head (NPSH) requirements and to be fully hydraulically thrust balanced in normal service over a wide capacity range.

Operating a pump at, or close to, its design flow rate, is in the best interest of the pump lifespan and operating performance. However, operating the pump at flow rates that are less than this, cannot always be avoided. This is particularly the case when the

shore receiving facility cannot accept the rated flow and when approaching the stripping level or during stripping. Generally, it is better to operate one pump at the design flow rate rather than two pumps running at 50% flow each.

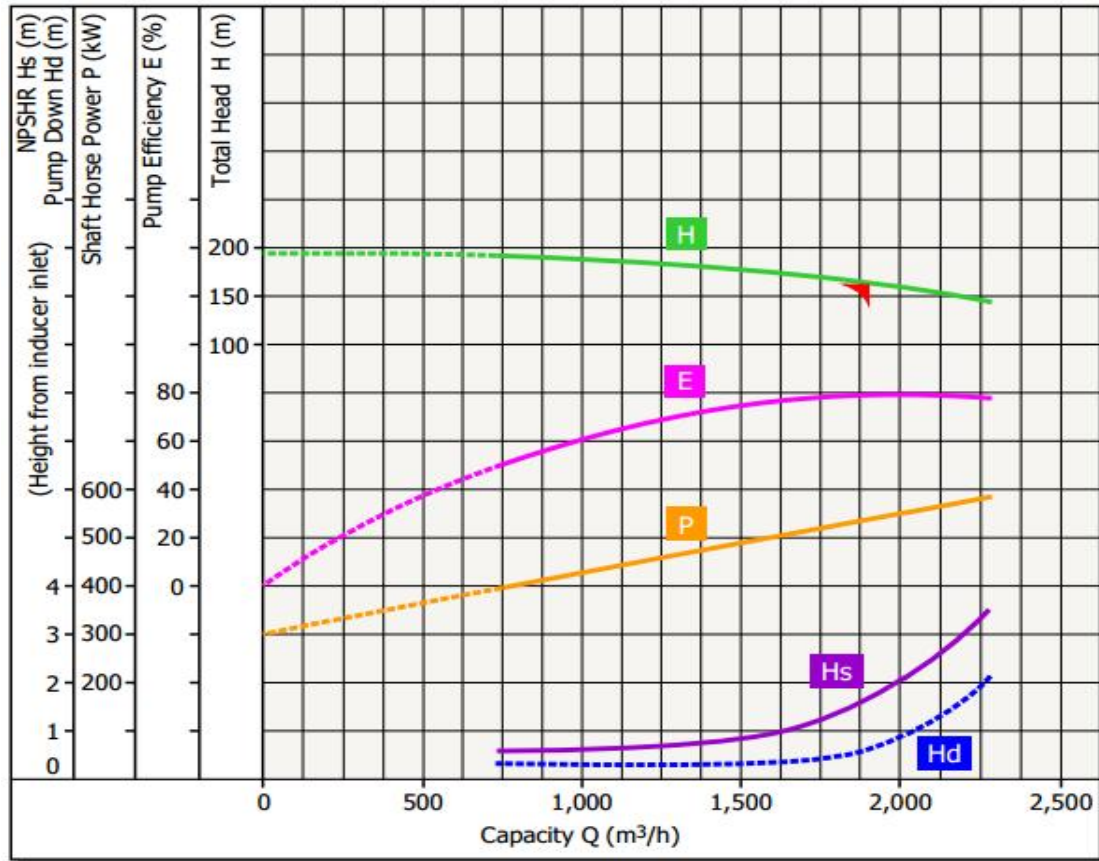

**Figure 13** Cargo pump characteristic curve

**Total head cure H (green)**

This shows the capacity of the pump as a function of the head developed by the pump. Capacity is given in terms of volumetric flow rate, normally m<sup>3</sup>/hr (Q), while head developed by the pump is given in terms of meters liquid column (mlc). Adopting these parameters of volumetric flow rate and head means that the capacity/head curve is the same for any liquid.

### **NPSH curve Hs (purple)**

This shows the Net Positive Suction Head (NPSH) requirement for the pump in question as a function of pump capacity. The net positive suction head requirement at any flow rate through the pump is the positive head of fluid required at the pump suction to prevent cavitation at the pump impeller. NPSH considerations are particularly significant when pumping liquefied gases because the fluid being pumped is always essentially at its boiling point. It must be remembered that if cavitation is allowed to occur within a pump, not only a damage will occur to the impeller but also the shaft bearings themselves will be starved of cargo. This will restrict cooling and lubrication at the bearings and damage will quickly result.

### **Power consumption curve P (yellow)**

This shows the power absorbed as a function of pump capacity. This curve is normally given for a specific liquid density and can be converted for any liquid by multiplying by the ratio of specific gravities.

## **4.3 ESD System**

The emergency shutdown (ESD) system is a requirement of the IMO code for the carriage of liquefied gases in bulk and is a recommendation of SIGTTO. It is fitted to protect both the ship and terminal in case of power loss, cryogenic or fire risks, on either the ship or in the terminal. At a number of locations around the ship (bridge front, gangway, compressor room and cargo control room, emergency control station), pneumatic valves or electric push buttons are provided. When operated, these controls close remotely actuated valves and stop cargo pumps and compressors (where appropriate). This provides an emergency-stop facility for cargo handling. Such

emergency shut-down (ESD) is also required to be automatic upon loss of electric control or valve actuator power. Furthermore, if a fire should occur at tank domes or cargo manifolds (where fusible elements are situated), the ESD system is automatically actuated. Individual tank filling valves are required to close automatically upon the actuation of an overfill sensor in the tank to which they are connected. ESD valves may be either pneumatically or hydraulically operated but in either case they must be fail-safe; in other words they must close automatically upon loss of actuating power.

ESD will be initiated by one of the following:

- Manual activation by personnel using the ESD pushbuttons
- Blackout of the ship
- Shore activation of their ESD system
- Fusible links around each tank domes, manifold and compressor house in case of fire
- Cargo tank Very High level alarm
- Low tank pressure
- Hold/cargo tank differential pressure
- Low cargo valves hydraulic pressure
- Low control air pressure
- Fire extinguisher system released

The initiation of ESD will lead to the following:

- All ESD manifold loading valves will close
- The gas compressors will trip
- The main discharge and spray pumps will trip

- All shore pumps will trip
- Master gas valve to engine room will close
- Inert gas generator will trip

The requirements of the cargo Emergency Shutdown (ESD) system are to stop cargo liquid and vapour flow in the event of an emergency and to bring the cargo handling system to a safe, static condition. The ESD system minimizes potential risks during the transfer of liquefied gases between ship and shore loading and unloading installations. It provides a quick and safe means of stopping the transfer of cargo and isolating ship and shore cargo systems in a controlled manner, either manually or automatically, in the event of fault conditions that affect the ability of the operator to control safely the transfer of cargo. Most export terminals, and an increasing number of import terminals, now have a second level of protection providing for the rapid disconnection of the loading arms from the ship. These two levels of cover are known as "ESD-1" and "ESD-2".

Automatic shut down for fire is initiated by fusible plugs which are generally located at each tank dome, manifold platform, in the cargo compressor and electric motor rooms. ESD1 may also be initiated automatically under conditions such as the following:

1. Blackout of the ship.
2. Vapour header pressure falls below pre-set limit.
3. Individual tank pressure falls below pre-set limit.
4. Extreme liquid level in any cargo tank.
5. Low cargo valve hydraulic pressure.

ESD2 is normally initiated by the terminal and will result in all actions as ESD1, plus the initiation of a dry break of the shore arm from the ship. ESD2 may be initiated manually, for example, in the event of a terminal emergency, or automatically, for example, if the ship moves outside the movement envelope of the chocks (a flexible coupling used in high-pressure lines).

#### **4.4 HD / LD Compressors**

##### **High Duty compressor**

Two high duty (HD), equally sized electric motor driven centrifugal compressors are installed in the compressor room on deck. They are provided for handling and returning ashore the LNG cargo vapours created during cool down and cargo loading. This keeps cargo tank pressure within accepted limits. They are also used for pressurization of a Moss cargo tank if an emergency discharge is necessary, because the pumps in the cargo tank would not be available. Gas is discharged through the vapour header (line) into the top of the cargo tank, where the resulting pressure in the tank forces any liquid out via the liquid loading pipe.

The compressors must be suitable for both duties, vapour return and warming-up and be able to handle methane vapour, inert gas or mixture of both. Undersized compressors will lead to extended cargo handling times and, particularly in the case of cool-down, the ship remaining on the berth longer. For both duties it may be assumed that the maximum capacity can be met by running both compressors in parallel.

## **Low Duty compressor**

Not all ships are fitted with low duty (LD) compressors as some use HD compressors for dual purpose. The LD compressors are fitted with lubricated vanes and oil buffered mechanical seals, that compress the cold boil-off gas from LNG tanks at a temperature range of -140°C to -160 °C. The boil-off gas pressure in the cargo tanks should normally be kept at 45-180 mbars. On passage, the boil-off rate can vary through changes in the barometric pressure, ambient temperature and the sea conditions. This can be between 0.10% and 0.15% of the cargo volume per day. The LD compressors handles the cargo boil-off on passage. Vapours are collected from a header connected to each cargo tank and then they are passed through a heater en-route to the engine room.

Under normal operating conditions only one of the LD compressors is in use at any time. There is no automatic changeover provided and failure of a compressor will not automatically stop gas firing but will result in a free flow condition that maintains the supply of gas to the burners.

The HD/LD compressors are driven by electric motors that are installed in an electric motor room and segregated from the compressor room by a gas-tight bulkhead. The shaft penetrates are bulkhead with a gas-tight seal.

## **4.5 LNG / Forcing Vaporizer**

### **LNG Vaporizer**

The LNG vaporizer is a shell and tube type heat exchanger located in the cargo compressor room. During unloading the volume of unloaded LNG has to be replaced,



either from the shore or by utilizing the LNG vaporizer and is used for vaporizing LNG liquid for the following operations:

- When discharging cargo at the design rate without the availability of a vapour return from the shore. If the shore is unable to supply vapour return, liquid LNG is fed to the vaporizer by using one stripping pump or by bleeding from the liquid header. The vapour produced leaves the vaporizer at approximately  $-140^{\circ}\text{C}$  and is then supplied to cargo tanks through the vapour header.

Vapour pressure in the cargo tanks will normally be maintained at 1100 mbar (minimum 1040 mbar) during the whole discharge operation. Additional vapour is generated by the tank sprayer rings, the LNG being supplied by the stripping/spray pump.

- $\text{LN}_2$  vaporization for inerting the cargo tank and insulation spaces. Supply the cargo tanks with vaporized nitrogen using liquid nitrogen ( $\text{LN}_2$ ) supplied by the terminal, in the event of the vessel's inert gas generator being inoperative. This operation would only be carried out at the initial inerting of cargo tanks or the first loading terminal after dry dock. The vaporizer outlet temperature must be controlled at  $+20^{\circ}\text{C}$  during the inerting operation.
- Purging of cargo tanks with vapour after inerting with inert gas and prior to cool down. LNG is supplied from the shore to the vaporizer via the stripping/spray line. The vapour produced at the required temperature of  $+20^{\circ}\text{C}$  is then passed to the cargo tanks.

- The design capacity of the vaporizer will determine the time that this cargo operation will take emergency forcing by manual operation. The LNG vaporizer can function as the forcing vaporizer when the forcing vaporizer has failed. The output temperature in emergency forcing is  $-25^{\circ}\text{C}$ .

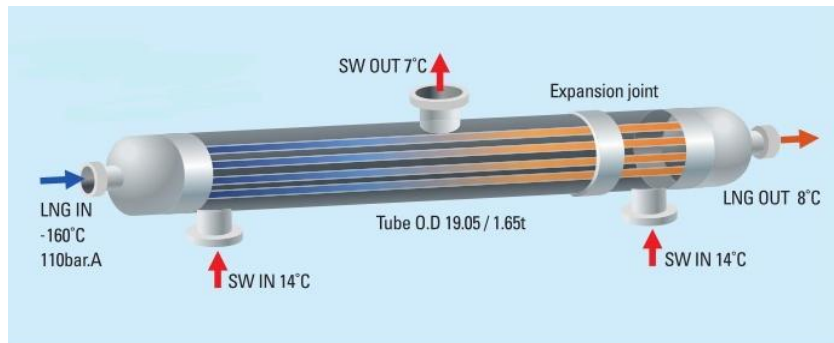

**Figure 14** LNG Vaporizer

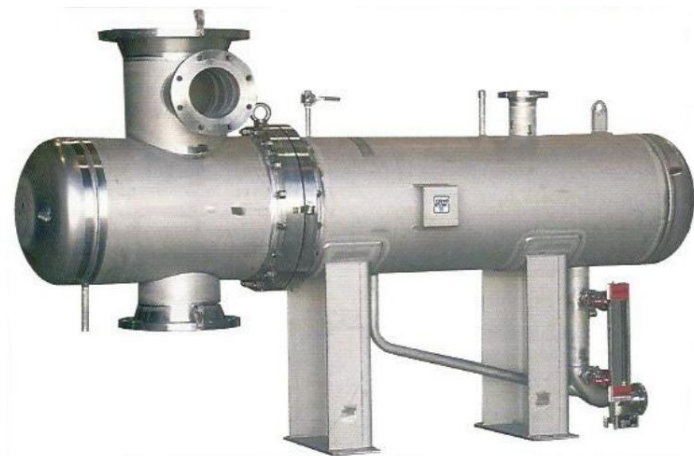

**Image 5** LNG Vaporizer

## **Forcing Vaporizer**

The forcing vaporizer is used for vaporizing LNG liquid to provide gas for burning in the boilers to supplement the natural boil-off. The LNG is supplied by a stripping - spray pump and flow is controlled by an automatic inlet feed valve that receives its signal from the boiler's gas management system. Its controllers maintain the vapour main pressure at its set point by supplementing the natural boil-off rate from the cargo tanks by vaporizing part of the LNG cargo when operating in fuel gas only (100% gas) mode.

The forcing vaporizer is located in the cargo compressor room. The forcing vaporizer is used for vaporizing LNG liquid to supply gas to the Dual Fuel (DF) engines with additional fuel gas when the natural boil-off pressure is insufficient to maintain the demand when the engines are operating in fuel gas mode and to increase the tank pressure in dual fuel mode.

The forcing vaporizer should achieve an outlet temperature similar to that of the vapour header and be started and stopped under local manual control. It should have automatic capacity control from 0% to 100% of the boiler load and be integrated with the main propulsion plant control system.

Both forcing vaporizers are fitted with spiral wires to promote turbulence, ensuring efficient heat transfer and production of superheated LNG vapour at the exit of the tube nests.

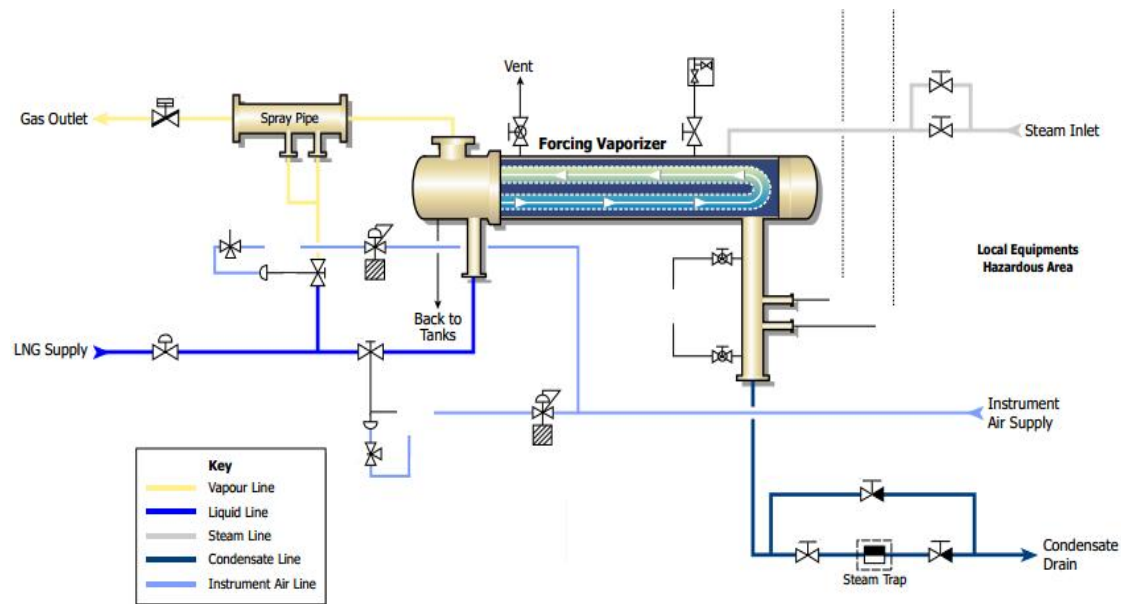

Figure 15 Forcing vaporizer layout

## 4.6 Gas Heaters

When discharging refrigerated cargos into pressurised shore storage, it is usually necessary to heat the cargo so as to avoid low-temperature fragility of the shore tanks and pipelines. The heaters are typically heat exchangers of the shell and tube type. The heating surface consists of straight tubes arranged so that cargo vapour flows through the tubes and steam condenses outside of the tubes. The end covers are welded to the tube sheets but are flanged so that the tubes can be inspected or plugged onboard the ship if required. Sometimes they may be direct steam heated, with automatic temperature control, achieved by injecting cold gas into the hot gas outlet, and a system of automatic protection against freezing of the condensate side of the heaters.

On some ships the heaters may be used for heating inert gas that has been supplied from the inert gas generator for an inerting operation to ensure a better temperature differential for stratification. The main purpose of the vapour heaters is to heat the boil-off to be used for tanks warm-up prior to a dry docking when preparing tanks for

inspection purposes or for using of GCU (Gas Combustion Unit) to burn the inert gas/natural gas mixture.

When returning heated vapour to the cargo tanks, the temperature at the heater outlet should not exceed the manufacturer's instructions. This value is typically between +50°C to +80°C and avoids possible damage to the cargo piping insulation, safety valves and the cargo tank itself.

There are two steam heated boil-off/warm up heaters located in the cargo compressor room that are used as follows:

- High duty heater used for heating the LNG vapour, which is delivered by the HD compressors at the specified temperature for warming up the cargo tanks before gas freeing.
- Low duty heater, which is controlled from the engine room and used for heating boil-off gas supplied to the main boilers via the LD compressor.

### **HD Heater**

When a tank has to be warmed up, the vapour heaters are used to heat up the gas. The flow rate is substantially larger during this mode, and both heaters, low and high duty, have to be used simultaneously to provide the required duty. The control strategy is in principle the same as for the boil-off gas mode with a temperature set point of +80°C. The inlet temperature will be -130°C, and at design condition, the heaters will operate at maximum duty and no cold gas will be bypassed.

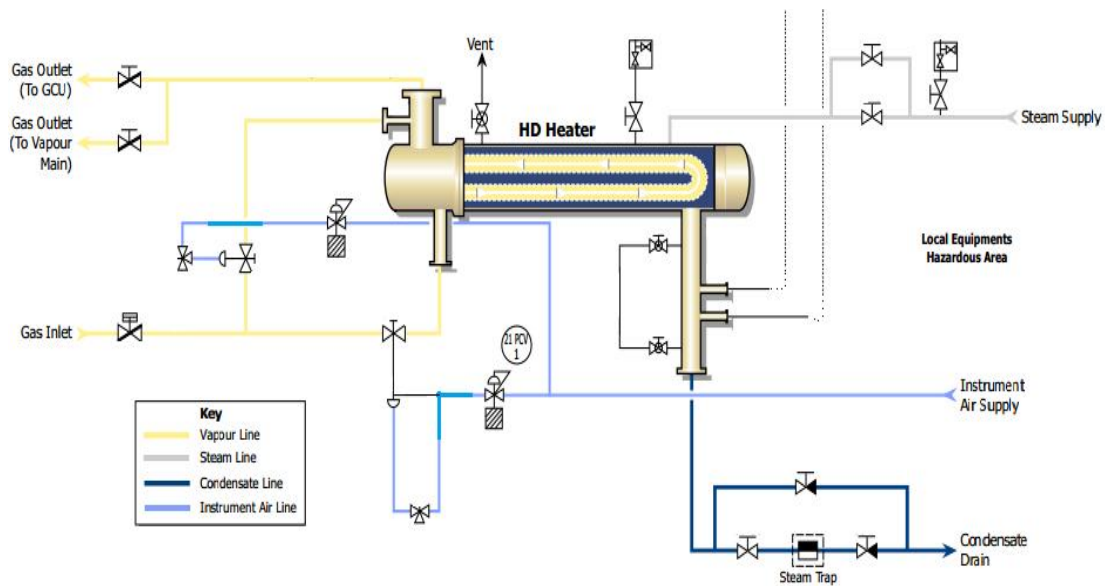

**Figure 16** HD Heater layout

### **LD Heater**

The main purpose of the vapour heaters is to heat the boil-off to be used as fuel gas during voyage. The boil-off gas from the LD compressors will have a temperature on average  $-90^{\circ}\text{C}$  to  $-10^{\circ}\text{C}$ . For the design case the gas will be heated to approximately  $70^{\circ}\text{C}$  in the heater, but after mixing with the cold bypass gas, the temperature of the gas to the burner will be  $20^{\circ}\text{C}$ . The temperature is controlled by 2 control valves. One control valve is located in the heater inlet and the other valve is on the bypass vapour line. When starting the heater, the bypass valve is fully closed and the inlet valve will be fully open. When the gas outlet temperature rises above the desired value ( $20^{\circ}\text{C}$ ) the controller will adjust the bypass valve to maintain the temperature at the set-point. To heat up the boil-off gas, only one of the heater is used at a time.

## After Heater/Cooler

The after heater/cooler is installed downstream of the LD compressors. This heat exchanger is installed for cooling and heating of the fuel gas in order to meet the temperature range required by the Dual Fuel engines. Fresh water is used as a cooling/heating medium. In case of low temperature at the fresh water outlet, the fresh water valves will be closed. There is no temperature control on after heater/cooler as the cooling water flow shall remain constant and permanent.

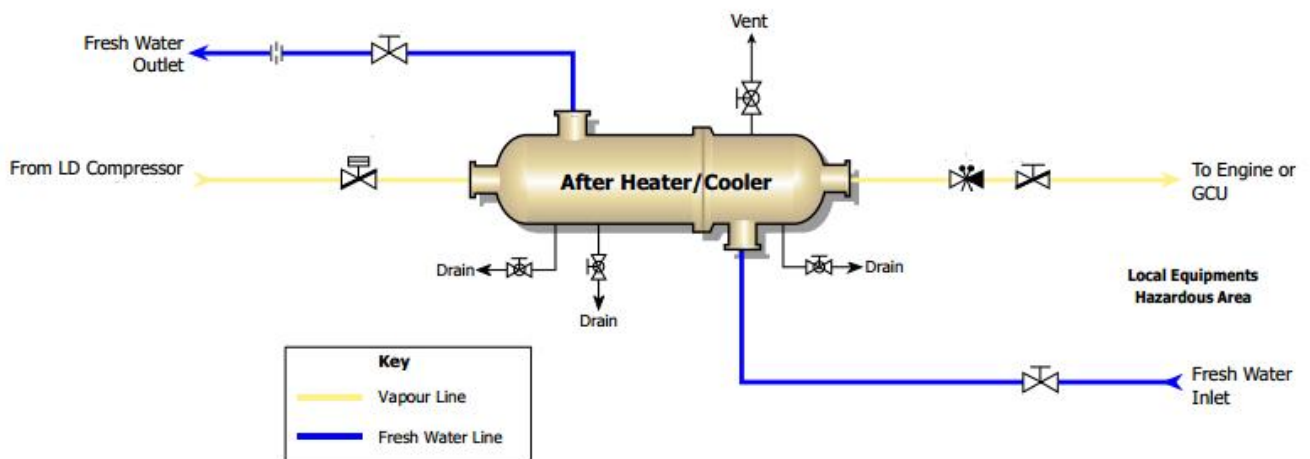

**Figure 17** After Heater/Cooler layout

## 4.7 Custody Transfer System

LNG is one of the most difficult commodities to transfer as it is transported at fully refrigerated conditions at a temperature of  $-161.5^{\circ}\text{C}$  (at boiling point). At these low temperatures, measuring, sampling, quantification and testing of LNG creates a number of practical problems that should not be underestimated. Companies now require more and more accurate and reliable figures on every LNG shipment as there is no acceptance of mistakes or "built-in" inaccuracies. This has placed an increased

focus on the accuracy of the Custody Transfer System (CTS) and the experience of the nominated cargo surveyor(s).

LNG is bought and sold according to its total heat content. To determine this value, the total mass of cargo (volume × density) is measured and multiplied by the calorific value (CV) of the mixture. The CTS allow cargos to be bought and sold by heat value in BTU (British Thermal Units) or in Kilo/cal. To determine the amount of energy transferred, an accurate determination of volume, density and composition must be made. After all, the CTS facilitates accurate cargo calculation. The CTS measures cargo level, liquid and vapour temperatures and the vapour pressure in each cargo tank.

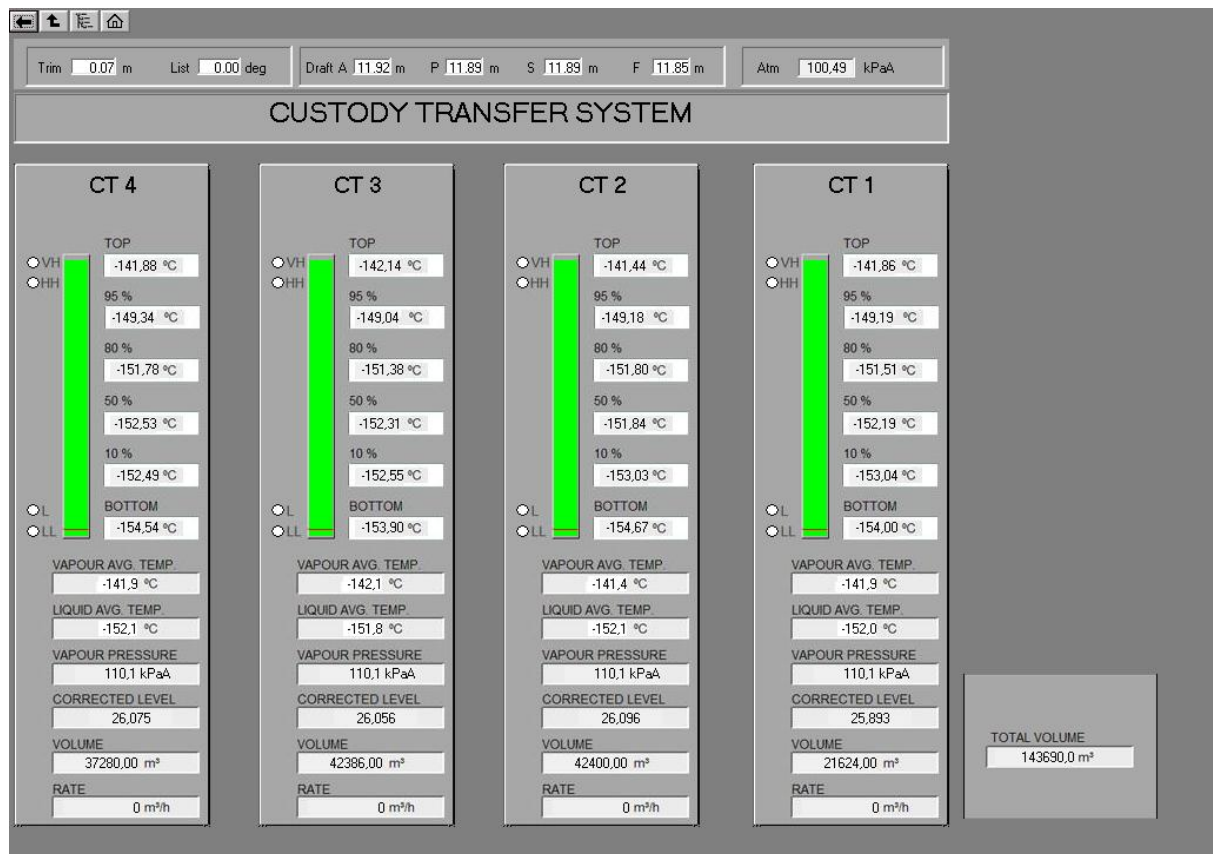

Figure 18 Custody Transfer System



At the present time there are no practical instruments available to determine the net calorific content transferred during loading and discharge so that for the moment this value is determined partly by measurement and partly by analysis of cargo calculation by means of the following formula:

$$Q=(V \times d \times HL)-(V \times T_s \times P_v \times H_v)/(T_v \times P_s)$$

where:

- **Q:** Total energy transferred
- **V:** Cargo volume loaded or discharged at an average temperature TL (m<sup>3</sup>)
- **d:** Density of cargo at temperature TL (kg/ m<sup>3</sup>)
- **HL:** Gross heating value of the cargo (Btu/kg)
- **T<sub>s</sub>:** Standard temperature (°K)
- **T<sub>v</sub>:** Average temperature of gas in the cargo tanks (°K)
- **TL:** Average temperature of liquid in cargo tanks (°K)

## **CHAPTER 5 CARGO HANDLING**

### **5.1 Loading operation - Initial voyage**

#### **Tank inspection**

Before any cargo operations are carried out it is essential that cargo tanks are thoroughly inspected for cleanliness; that all loose objects are removed; and that all fittings are properly secured. In addition, any free water must be removed. Once this inspection has been completed, the cargo tank should be securely closed and air drying operations may start.

#### **Drying operation**

Drying the cargo handling system in any refrigerated ship is a necessary precursor to loading. This means that water vapour and free water must all be removed from the system. If this is not done, the residual moisture can cause problems with icing and hydrate formation within the cargo system.

The drying operation of a hold space is carried out in order to prevent tank insulation damage due to condensation of moisture inside it, prior to initial cool down operation and periodically during a voyage. Fresh air is dehumidified by the IGG and sent to a hold space as dry air with a dew point of  $-70^{\circ}\text{C}$  to  $-40^{\circ}\text{C}$  through its bottom section, humid air inside the hold space is released through the vent pipe provided in the upper portion of the tank. The hold space should be maintained at a higher pressure than the atmospheric pressure.

Before delivering dry air into a hold space, this must be completely dry up beginning from the bottom section of the hold space, particularly the bilge well. When drying a hold space after completing the inerting operation of a cargo tank, relevant

equipments and inerting/aerating lines must be purged with dry air to prevent the ingress of inert gas into the hold space. This is because the hold space holding dry air sent into it is kept almost sealed till the next dry docking and, in addition, about 15% CO<sub>2</sub> gas is present in the inert gas, which may corrode aluminum cargo tanks and destroy insulation materials. When the dew point of the hold space drops below than the planned temperature, the drying operation must be completed.

- **Drying using inert gas from the shore**

Drying may be carried out as part of the inerting procedure when taking inert gas from the shore and this is now commonly done. This method has the advantage of providing the dual functions of lowering the moisture content in tank atmospheres to the required dew point and, at the same time, lowering the oxygen content. A disadvantage of this and the following method is that more inert gas is used than if it is simply a question of reducing the oxygen content to a particular value.

- **Drying using inert gas from ship's plant**

Drying can also be accomplished at the same time as the inerting operation when using the ship's inert gas generator but satisfactory water vapour removal is dependent on the specification of the inert gas system. Here, the generator must be of suitable capacity and the inert gas of suitable quality - but the necessary specifications are not always a design feature of this equipment. The ship's inert gas generator is sometimes provided with both a refrigerated dryer and an adsorption drier which, taken together, can reduce dew points at atmospheric pressure to -45°C or below.

- **On board air-drying systems**

An alternative way to drying with inert gas is by means of an air-drier fitted on board. In this method, air is drawn from the cargo tank by a compressor or provided by the on board inert gas blower (without combustion) and passed through a refrigerated drier. The drier is normally cooled by R22 refrigerant. Here the air is cooled and the water vapour is condensed out and drained off. The air leaving the drier is, therefore, saturated at a lower dew point. Further reduction of the dew point can be achieved by a silica gel after-drier fitted downstream. Thereafter, the air may be warmed back to ambient conditions by means of an air heater and returned to the cargo tank. This process is continued for all ship tanks (and pipelines) until the dew point of the in-tank atmosphere is appropriate to carriage conditions.

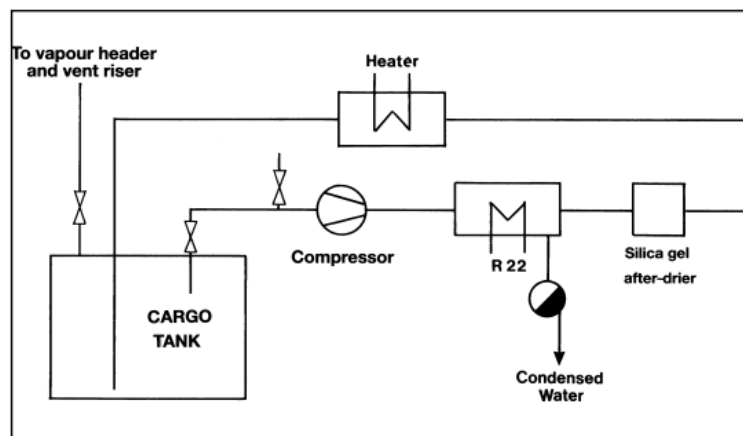

**Figure 19** Air drying circle operation

### **Nitrogen purging**

Before putting a cargo tank into service (on a newly built vessel or after repairs), the humid atmosphere in the insulation spaces must be replaced by a dry, inert

atmosphere of gaseous nitrogen. This is essential to preventing condensation (which would freeze the insulation boxes) from forming when the tank is filled with natural gas, and to ensure that the atmosphere is inert. Further, leaks of LNG across the primary barrier can readily be detected in the nitrogen atmosphere.

The capacity of the ship's Nitrogen Generator (NG) is insufficient for the initial purging, so liquid nitrogen is pumped aboard from shore-side. In normal operations, the insulation space is maintained by alternating the relief of and make-up filling of Nitrogen from the NG and the buffer tank. The procedure consists of partially evacuating the insulation space with the electric vacuum pumps, then pumping Nitrogen in, and repeating the process until the oxygen content is less than 2%.

### Inerting

Inerting takes place immediately after the drying operation. Inerting cargo tanks, cargo machinery and pipelines is undertaken primarily to ensure a non-flammable condition during subsequent gassing-up with cargo. The inert gas generator is used across all of the cargo tanks to reduce the O<sub>2</sub> level to a typical value of 2% and the dew point to -45°C or dryer.

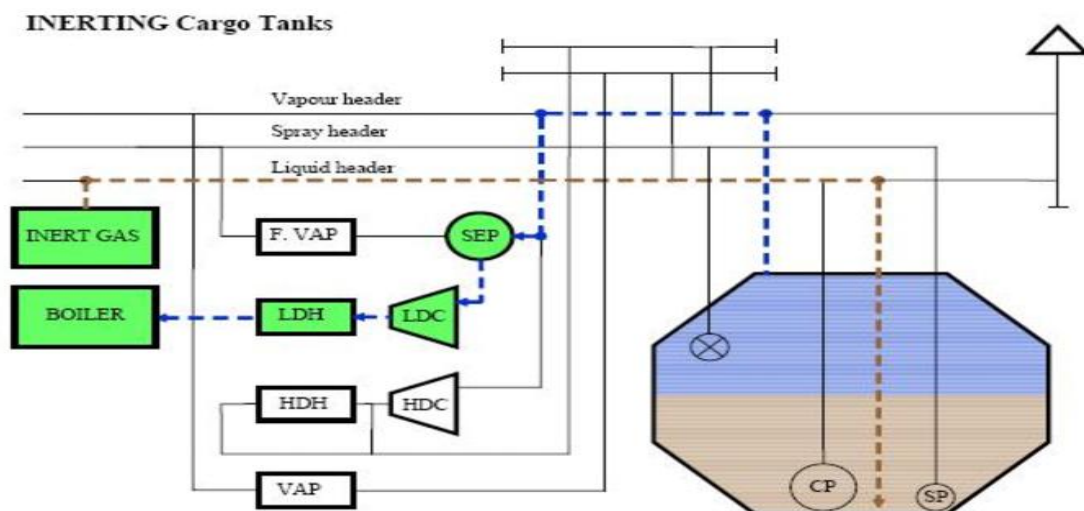

**Figure 20** Inerting operation

- **Inerting of Annular spaces for Moss type vessels**

The space between the surface of a cargo tank and insulation is called annular space, insulation space or wedge space. Annular Space is inerted with nitrogen gas and continuously supplied from N<sub>2</sub> generator through the N<sub>2</sub> bleed line in service in order to ensure adequate path in the insulation space for the gas detection system.

- **Inerting Inter Barrier Spaces (IBS) and Insulation Spaces (IS) for Membrane type vessels**

The space between the primary and the secondary barrier is called inter-barrier space (IBS). The space between the secondary barrier and the inner hull is called insulation space (IS). The pressure in these spaces must be regulated at a pressure slightly above atmospheric pressure in order to prevent any air ingress and the tank pressures must be always at least 10 mbar higher than the insulation space pressures. In normal operation, IBS and IS must be purged with nitrogen in relation with atmospheric pressure variations and cooling or warming of the spaces during loading or unloading, and IBS should be continuously purged with nitrogen if gas is detected by micro-leakage of the membrane.

### **Gassing Up**

After the cargo tanks have been inerted, they are purged at the load port with warm LNG vapour. This helps to remove the gases, such as CO<sub>2</sub>, that could freeze at the cryogenic temperatures of the LNG. This stage is commonly known as purge drying, purging or gassing-up. LNG liquid is loaded from the shore to the LNG vaporizer and

then warm LNG vapour, at approximately +20/+25°C, is introduced to the top of the tank. This creates an interface between the LNG vapour and the inert gas in the tank.

The inert gas is expelled from the tank by displacement via the loading lines and is vented to atmosphere from the forward mast riser (or depending on the shore regulations, the shore flare). The operation is continued until a gas reading of 5% methane by volume is achieved at the mast riser. When this occurs, the HD compressors may be lined up to transfer the vapour ashore. The gassing-up operation is considered complete when the methane content exceeds 88% in each cargo tank. Note that the LNG consists of approximately 95% methane.

### **Cool Down**

Cool down is the process that brings the cargo containment system to a temperature that does not cause excessive boil-off during loading and prevents thermal shock to the primary containment system. The cool down operation is achieved by introducing LNG, which is supplied from the terminal, through the spray header and cool down grids at the top of each tank. The liquid LNG will vaporize at the sprays and cold LNG vapour will enter the tanks. The amount of LNG required for cool down is proportional to the surface area to be cooled.

- On Membrane ships cool down continues until -130°C is achieved. An example of how long cool down takes:  
140.000 m<sup>3</sup> membrane approximately 10 hours from +40°C to -130°C.
- On Moss system ships cool down is continued until -115°C is achieved at the equatorial ring. An example of how long cool down takes:  
135.000 m<sup>3</sup> moss system approximately 24 hours from +40°C to -115°C.

The primary reasons for cooling the cargo lines are:

1. To minimize the possibility of leaks being created at joints with valves or other sections of pipeline as they contract when cargo is passed.
2. To reduce the possibility of sudden shock loadings on bellows as pipes contract rapidly.
3. To avoid the formation of vapor locks in the pipelines when cargo is introduced. If LNG is introduced into a warm pipeline the initial cargo will vaporize, create a large pressure that can 'block' the loading of the liquid. It is then possible that this vapour will then condense very rapidly as the temperature reduces below the condensation point, allowing the liquid to surge along the pipeline possibly resulting in damage to the pipelines, valves or connections.

Before loading operations begin, the pre-operational ship/shore procedures must be thoroughly discussed and followed. Also, the water curtain should be in operation before any arms connection and should remain in operation until after all arms have been disconnected. Water curtain is used at the manifold area for hull protection because the LNG is very corrosive. Appropriate information exchange is required and the relevant parts of the ship/shore safety check list should be completed. When all these procedures completed the initial loading operation can start. To the forthcoming loading operations almost the same procedures must followed.



## **5.2 Loading operation - Except the initial voyage**

### **Line Cool Down**

The terminal should be instructed to begin pumping at a slow rate for approximately 15 minutes, in order to gradually cool down the terminal piping and the ship's headers. Slowly increase the terminal pumping rate until the liquid main and spray headers have cooled down (approximately 15-20 minutes). Cargo tank pressures should be monitored closely and if required the HD compressor should be adjusted in order to maintain a constant vapour pressure.

In order to avoid the possibility of pipe sections hogging, (contracting at the bottom more than at the top and thus causing flanges and long pipe sections to be stressed) the liquid header and crossovers must be cooled down and filled as quickly as possible. Prior to commencing the loading operation the cargo pipelines have to be cooled.

### **Air purge of loading arms**

After the connection of loading arms, air should be purged from the loading arms and the tips of manifold pipes. N<sub>2</sub> gas is lead into the loading arms from injection lines connected to the arms, and then pressurize up to about 2 bar. After pressurization, the ship's liquid manifold vent valve and vapor manifold vent/drain valve are opened to release air and N<sub>2</sub> gas into the atmosphere. While this operation is repeated two or three times, a leak test (with soap solution) is conducted at the same time. Air purge comes to an end when the oxygen content of the purged gas has dropped below 2%.

### **Loading arms cool down**

The cool down of the loading arms is performed from shore side by using a small capacity pump. At a discharge port, the arms are cooled down by sending in LNG by ship's spray pump. The ship will prepare all the lines, crossovers, manifolds and spray rails for cooling down. The terminal will begin the cool down, gradually cooling the lines on the jetty and then the ship. The terminal will normally confirm that they have completed cool down before the ship. When the ship has completed this operation, and when the liquid header is approximately at  $-157^{\circ}\text{C}$ , the tank loading valves must set and after the terminal's confirmation must commence loading/ramp-up at the agreed rates.

### **Loading operation**

After the loading arms are connected, they are purged with  $\text{N}_2$ , and leak tests are conducted using soapy water. When the loading arm is purged, the  $\text{O}_2$  level must be less than 1% and the dew point below  $-50^{\circ}\text{C}$ .

After the loading arms are connected a test of the ESDS will be initiated. The closure time of the remote actuated valves will be timed to verify that they close within 30 seconds. Also, the completion of the ship/shore safety checklist with the terminal representative must be done.

LNG is loaded via the loading manifolds to the liquid header and then to each tank filling line. The boil-off and displaced vapour leave each tank via the vapour suction to the vapour header. The vapour is initially free-flowed to shore via vapour crossover manifold and, as tank pressure rises, one compressor is brought into operation to increase the gas flow to shore and limit the vapour main and cargo tank pressure. As the loading rate increases, it is important to monitor the tank pressures and to start one

HD compressor. If the compressors are unable to cope with the volume of boil-off and displaced gas, it will be necessary to reduce the loading rate.

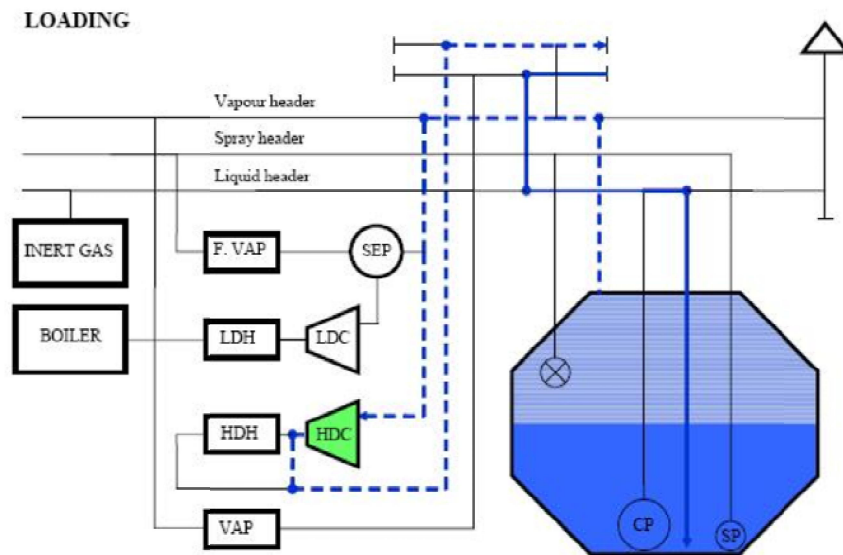

Figure 21 Loading operation

### **Bulk loading**

When all lines and valves are fully cooled the vessel can commence ramping up the loading rate in the sequence agreed with the terminal. Deballasting should be commenced in accordance with the cargo plan. The cargo should be evenly distributed during the loading. The HD compressors have to be adjusted in line with loading rate to ensure that the tank vapour pressure remains at a level safely below the lifting pressure of the relief valves. The Nitrogen system must be perform correctly.

Moss vessels will require the temperature gradient (with particular reference to the equator) to remain within certain limits, the tank temperatures are therefore to be closely monitored. Hourly temperatures must be recorded in order that, if required, the vessel can verify that temperature has stayed within the manufacturers tolerances.

## **Topping off**

As the vessel approaches completion of cargo operations the tanks should be staggered in line with the cargo plan, typically this would leave a gap of 10 to 15 minutes between completion of each tank. The terminal must be notified well in advance and in line with the agreed procedure that the vessel is topping of and will need to reduce loading rate. Notification should be made at least 30 minutes before reducing rate.

Membrane tanks normally fill to 98,5% where as Moss vessels normally fill to 99.5%. On all vessels the independent alarms activate at preset filling levels, the upper alarm activates the ESD if previous alarms are ignored.

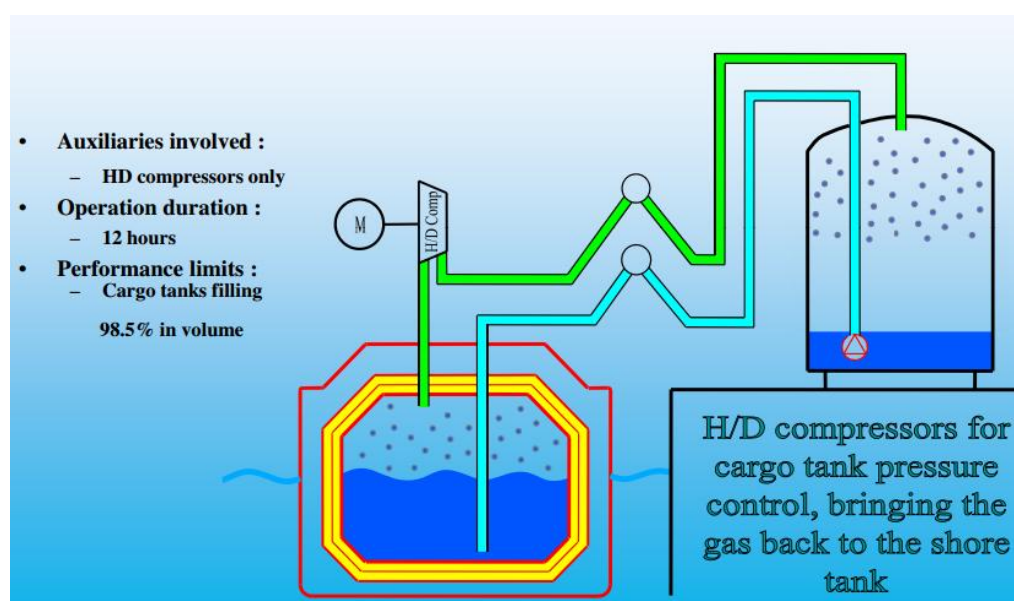

**Figure 22 Loading**

## **Deballasting**

The deballasting operation is carried out simultaneously with the cargo loading operation. Before any de-ballasting commences, all ballast surfaces should be visually

checked and confirmed as free from oil or other pollutants. This check must be carried out through inspection hatches / tank lids. This is particularly important for ballast tanks which are situated adjacent to fuel oil tanks. If fitted, gas detection / sampling systems may not indicate the presence of hydrocarbons particularly in small quantities.

Deballasting is initially carried out by gravity discharge until the level in the ballast tanks approach the vessels water line when the ballast pumps are used. The ballast should be adjusted to keep a small stern trim to aid with the stripping of the ballast tanks. The flow rate of the ballast should be adjusted to keep the ship within 1 meter of the arrival draft or as specified by the terminal. Deballasting should normally be completed before the start of the topping off of the cargo tanks.

### **Draining and Purging of liquid arms**

After all cargo pumps have stopped and shore lines have been drained, ship's manifolds must be pressurized with nitrogen to up to 5 bar. This operation must continue until there is no more liquid on drain valve and methane content is below 2%. When this is accomplished, the loading arms may be disconnected.

## **5.3 Discharging operation**

When a ship arrives at the discharge terminal, cargo tank pressures and temperatures should be in accordance with terminal requirements. This will help maximum discharge rates to be achieved. Before the discharge operation begins, the pre-operational ship/shore procedures should be carried out. Also, the same procedure as the pre-loading operation should be followed, the ESD cable and the discharging

arms have to be connected and water curtain must running. When the discharge arms have been connected, they purged and pressurized with N<sub>2</sub> supplied by the terminal. A pressure of 2 bar may be raised in each arm and soapy water is used to verify that no leaks exist. After that ESD tests have to carried out and terminal will inform the ship that they are ready for cool down and ramp up.

Liquid is pumped ashore by use of two submerged pumps installed at the bottom of each tank. In the process, the cargo tank pressure shows a decreasing tendency as the LNG level drops in the tank, resulting from the discharge of LNG. Conversely, shore tank pressure shows an increasing tendency with the receipt of LNG.

### **Discharging with vapour return**

The usual procedure is to start two pumps on re-circulation on one tank, then commence discharge from the tank. This usually takes 5 minutes. A similar procedure is then applied to the other tanks with a 5 min period between each tank. Once all pumps are running on 60 % load then slowly increased in turn to maximum specified load. As tank pressure falls, request receiving terminal to start sending vapour back to the ship and maintain tank pressure at agreed level.

Monitor the following items during discharge:

- Cargo tank level
- Cargo tank pressure
- Cargo pump motor load and discharge pressure
- Draft, trim and heel
- Ship condition

If stripping is planned for several tanks, it is recommended to keep the tank levels slightly different in each tank in accordance to the established “ramp down” procedures. Liquid draining and vapour purging of the arms is performed after completion of cargo discharging. After completing of draining and purging, the following operations are carried out:

- Final gauging after discharging
- Arm disconnection and de-icing (if necessary)
- Water curtain is stopped.

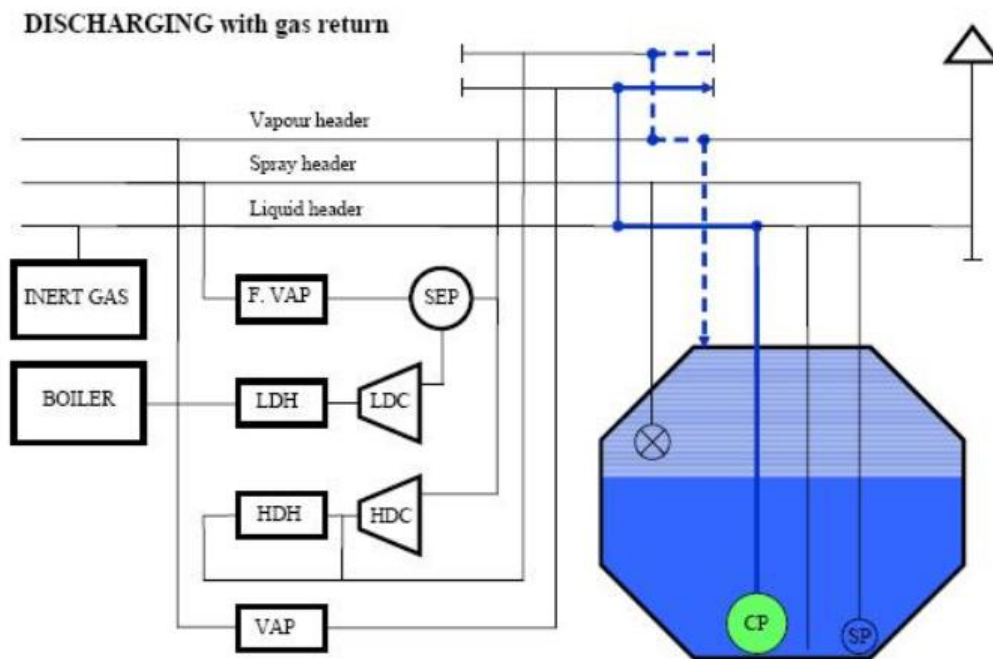

**Figure 23** Discharging operation with vapour return

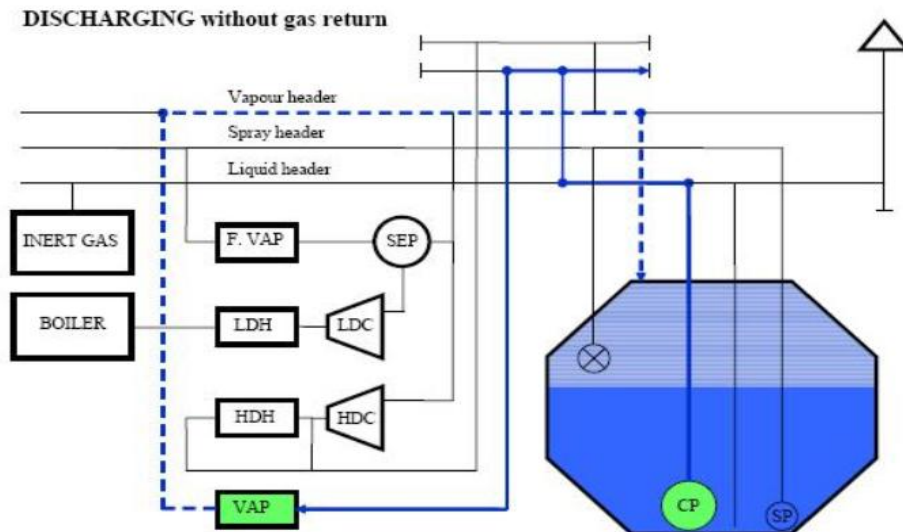

**Figure 24** Discharging operation without vapour return

### **Discharging without vapour return**

In rare instances such as gassing up a new terminal it may be necessary to discharge without the use of a shore return. In this instance the LNG is bled from the main liquid line to the vaporizer. The rate of vaporization is adjusted to maintain a constant tank pressure.

### **Cargo heel**

Subject to the trading patterns of the vessel and any particular requirements of the charterer, a cargo heel may be required. The heel quantity is allowed from the discharge plan and the pumps must be stopped at the required ullages. The heel figures should be carefully calculated, to ensure that there is maximum outturn of cargo at the discharge port, so the ship to arrive at the loading port with tanks cooled down by the onboard retained heel.

All LNG remaining in the downward leg of the loading arms and manifold connection is to be drained to the tanks through the liquid line assisted by nitrogen



pressure from ashore. The LNG and vapour manifolds are then purged with nitrogen until an acceptable hydrocarbon content is reached. On membrane vessels on shorter ballast voyages it is acceptable to carry a small amount of heel in each of the cargo tanks, and generally this will maintain the tank bottom temperature sufficiently cold that the vessel is able to berth and commence loading without additional tank cooldown being necessary.

### **Draining/Purging**

The procedures for draining / purging of the manifold lines and ships liquid lines are the same whether the ship has been loading or discharging. This is done by using a Nitrogen “punch” method. After completion of loading or discharging, this operation is carried out prior to disconnecting the liquid and vapour arms. Vapour in the vapour arm is fed to the cargo tanks through the vapour header by N<sub>2</sub> gas supplied from the terminal. Draining is normally carried out by pressuring the arms one by one.

### **Vapour from shore**

After any discharge operation, when the shore vapour arm has been disconnected and the vapour manifold closed, the vapour from shore valve have to be re-opened and then left open at least 20%. This will allow any increase in pressure, during the subsequent line warm up, to be transferred via the vapour header to the individual cargo tanks. Any excessive increase in pressure within the cargo tanks will initially be regulated by the automatic vent valve to the forward vent riser. If the pressure is not controlled sufficiently by the automatic vent valve, then individual tank relief valves will operate to vent pressure via the individual mast risers.

## **CHAPTER 6 SAFETY**

### **6.1 Liquefied gas fires and safety measures**

Natural gas contains numerous component gases but by far the greater percentage is methane (CH<sub>4</sub>), which represents between 60% - 95% of the total volume. This fact is important when considering the safety aspects for fire-fighters tackling an LNG fire. During the initial period of vaporization of the gas, ignition may be accompanied by a flash of varying proportions. However, because the velocity of propagation of a flame is lower in methane than in other hydro-carbon gases, it is unlikely that future ignition will have flash effect.

Cargo-related fires may be broadly categorised as follows:

- Jet fires from leaks at pumps or pipelines,
- Fires from confined liquid pools,
- Fire, from unconfined spillages,
- Fires in enclosed spaces, such as compressor rooms and
- Manifold fires.

#### **Jet Fires**

Small leaks from pump glands, pipe flanges or from vent risers will initially produce vapour. This vapour will not ignite spontaneously but, if the escape is large, there may be a risk of the vapour cloud spreading to a source of ignition. Should a gas cloud occur, ignition should be prevented by closing all openings to hazardous areas. Furthermore, the vapour cloud should be directly dispersed away from ignition sources by means of fixed or mobile water sprays. If ignition occurs, it will almost certainly flash back to the leak. Leaks from pipelines are likely to be under pressure

and, if ignited, will give rise to a jet flame. Emergency shut-down of pumping systems and closure of ESD valves should have already occurred but, even so, pressure may persist in a closed pipeline until the liquid trapped within has been expelled through the leak. In such a case, the best course of action is often to allow the fire to burn out. The alternative of extinguishing the fire has a high risk of further vapour cloud production and flash-back causing re-ignition. While the fire is being allowed to burn itself out, the surroundings should be protected with cooling water.

### **Liquid (pool) Fires**

Significant pool fires are not likely on tankers' decks because the amount of liquid which can be spilled in such a location is limited. The arrangement of the tanker's deck, with its camber and open scuppers, will allow liquid spillage to flow quickly and freely away over the tanker's side. In case of cargo leakage, open scuppers on gas carriers are an important feature to allow cold liquids to escape quickly so reducing the risk of metal embrittlement and the possibility of small pool fires on a tanker's deck. A liquid spillage on shore, from tank or pipeline ruptures, may involve large quantities but should be contained in bunded areas or culverts. Any ignition of the ensuing vapour cloud would then result in a pool fire.

### **Fires in Compressor Room**

Enclosed spaces containing cargo plant such as compressors, heat exchangers or pumps will normally be provided with a fixed and remotely activated fire extinguishing system such as carbon dioxide. Provided that no major disruption to the enclosure has occurred, these systems should be immediately effective.

## **Manifold Fires**

Manifold fires may consist of a jet fire as a result of leakage from the manifold flanges, or of a pool fire from a drip tray, although the amount of liquid in a drip tray is comparably small.

The avoidance of cargo fires depends upon preventing flammable cargo vapour, oxygen and sources of ignition coming together. Cargo vapours in flammable concentrations are likely to be present in areas such as cargo tanks, cargo machinery spaces and at times on deck. It is essential that all possible sources of ignition are eliminated from these areas, both by design and operation. Sources of ignition are inevitably present in spaces such as the accommodation, galleys and engine rooms, and it is essential to prevent cargo vapour entering these spaces. Personnel should be continuously on their guard, not only against the more obvious dangers, but also against unforeseen circumstances which could lead to flammable vapours and sources of ignition coming together.

If cargo gases are likely to enter the galley the cooking equipment must be shutdown until the source has been located and the gas dispersed. There are many possible sources of ignition in the engine room and gas carriers are designed to reduce the chances of gas entering these spaces. Doors are located away from the cargo area and ventilation fan intakes are positioned at high level. Entrances to the engine room must be kept shut at all times. Most LNG carriers burn cargo boil-off as fuel for propulsion and they are specially designed to ensure this is undertaken safely. Accommodation Cargo gases must be excluded from the accommodation areas and potential sources of ignition. All external doors and ports should be kept shut, especially during loading and discharging operations. As for the engine room,

ventilation fans are high above the deck to prevent gas entering these spaces and intakes are fitted with closing devices. Some doors may be fitted with airlocks and it is essential that these are used correctly. Also, it's important that all crew members know the risks of their actions and the equipment they use and, as per SOLAS and ISGOTT, only intrinsically safe equipment must be used on board LNG carriers.

The fire-fighting plan should be well thought out in advance and a concentrated effort made rather than 'hit and run' tactics, as these will only consume the vessel's extinguishing facilities without extinguishing the fire. Before attempting to tackle a large fire, you should seriously consider allowing the fire to burn itself out. Should an attempt to extinguish the fire be made, extensive use of 'dry powder' should be employed from as many dispensers as can be brought to bear. Fire-fighters should be well protected against heat radiation and possible flash burns, and approach the fire from an upwind direction. Power dispensers should sweep the entire area of the fire, but direct pressure of powder jets on to the surface of the liquid should be avoided. Should dry powder guns be used, fire-fighters should be well practiced in their use and be prepared for some kick-back effect. They should also be made aware that there is no cooling effect from the use of dry powder, and that re-ignition after a fire has been extinguished is a distinct possibility.

## **6.2 Fire-fighting systems**

The faster the extinguishing activity is effectuated, the greater the chance of a successful result. In choosing an extinguishing method, quencher remedy and capacity, the goal must be total elimination. One must also consider the amount of damage the extinguishing agent will cause to the area. In some parts of the vessel, one can choose between permanently installed extinguishing equipment and manual

efforts. On parts of the ship, a manual effort is the only alternative. Permanent equipment should be used in an area where the fire risk is large and has a large risk of spreading.

In the initial stages it is always preferable to isolate the fire by shutting off the source of fuel. This may not, however, always be possible. A final warning when tackling an LNG fire is that water should not be used directly, as this will accelerate vaporization of the liquid. This is not to say that surrounding bulkheads and decks cannot be cooled down with water sprays, provided that water running off is not allowed to mix with burning LNG.

### **Dry powder**

LNG carriers must be fitted with a fixed dry powder installation and portable extinguishers capable of fighting fires on the cargo deck area. At least two hand hose lines should be provided to cover this area and on large ships there are two systems in each side covering the port and starboard manifold and 10-12 hose cabinets strategically situated around the deck.

Each system consists of a tank containing sodium bicarbonate and cylinders containing N<sub>2</sub> gas under pressure. The system is operated by releasing the N<sub>2</sub> gas into the tank, which forces the mixture to the monitors and hose cabinets. When attempting to knock out the fire using a powder system, it is important to decide whether or not the water spray system should be cut off before the powder strike, because dry powders are normally soluble in water and a proportion may be eliminated if they have to pass through a water curtain. Irrespective of being the main extinguishing agent, it should be noted that dry powders doesn't provide cooling effect

and may be ineffective since a fire extinguished by dry powder can easily reflash from the hot metal.

### **Water spray systems**

A requirement is that a series of water spray nozzles are located at each tank liquid and vapour dome, at the amidships manifold, on the compressor house, on the forward bulkhead of the accommodation block and around the amidships cargo control room if applicable. The water for the operation of these nozzles is fed from a pump and line system independent from, but cross connected with, the ship's fire main. In addition to the above system, the sides of the accommodation block may be protected by spray nozzles supplied with water from the fire main via isolating valves.

Water is not a suitable medium of fighting an LNG fire directly as it will cause a massive expansion of the fire, through an increase in the rate of vaporization of the liquid to gaseous state. Water is however essential as a cooling medium for the surrounding area of an LNG fire and to protect personnel who may need to approach the site. Water is also essential for protecting steel work from the effects of extreme cold in the event of a liquid spill. It is necessary to avoid water running off adjacent structures and aggravating burning LNG, or splashing into spill trays which may contain LNG, thus causing it to overflow onto unprotected steelwork. Spill trays and areas under manifolds are in any case floodable with water to protect hull steelwork from damage due to exposure to the intense cold of LNG.

### **CO<sub>2</sub>**

CO<sub>2</sub> or nitrogen injected into safety relief valve outlets may be used as an effective means of extinguishing vapour fires at the vent risers. This is particularly valuable

once the initial pressure flow has subsided. After CO<sub>2</sub> has been injected into an enclosed space, the boundaries of the space should be kept cool - usually with water sprayed from a hose. The space should remain sealed until it is established that the fire has been extinguished and has sufficiently cooled so that it will not reignite with the introduction of oxygen. A CO<sub>2</sub> extinguisher system is available for cargo compressor rooms, electric motor rooms, inert gas dryer room and on some ships cargo control room. Ships plans should be consulted for what is applicable to the concerned vessel.

### **High Expansion Foam**

High expansion foam, adequately applied to the surface of a burning liquid pool (when confined within a bounded area), suppresses the radiation from the flame into the liquid beneath and reduces the vaporization rate. Consequently, the intensity of the pool fire is limited. Continuous application is required in order to maintain a foam depth of at least one to two meters. High expansion foam of about five-hundred to one expansion ratio has been found to be the most effective for this purpose.

Foam has a suffocating effect and acts as a cooling extinguishing agent. The suffocating or the cooling effect can be more or less the dominating effect, but depends on what material is burning and what sort of foam is used. By extinguishing a burning liquid with a surface temperature higher than +100°C, the cooling effect is the dominating force. This is caused by evaporation of the liquid that penetrates into the surface's layer of the burning material as the foam collapses. By extinguishing fire when the temperature in the surface is below +100°C, the extinguishing effect is connected with the heat-insulating foam and, above all, a differentiation effect.



### **6.3 Cargo hazards and medical treatment**

Carrying and handling various liquefied natural gases pose significant potential hazards including risk of injury, death or threats to environment. All gas carriers are designed so that, in normal operation, personnel should never be exposed to the hazards posed by the products being carried. This assumes, of course, that the ship and its equipment are maintained properly and that operating instructions are followed. Liquefied gas relate to the following hazards:

- Flammability
- Toxicity (poisoning)
- Asphyxia (suffocation)
- Low temperature (frostbite)
- Chemical burns

#### **Flammability**

All liquefied gases transported in bulk by sea, with the exception of chlorine, are flammable. The vapours of other liquefied gases are easily ignited. The exception to this is ammonia which requires much higher ignition energy than the other flammable vapours. Because of the very rapid vaporization of spilled liquefied gases, the spread of flammable vapour will be far more extensive than in the case of a similar spillage of oil. The chances of ignition following a spill of liquefied gas is, therefore, much greater. For this reason, many terminals establish ignition-free zones round jetties. The extent of these zones is based on a hazard analysis, taking into account local conditions and involving the dimensions of the gas cloud which could be formed.

## **Toxicity**

Toxicity is the ability of a substance to cause damage to living tissue, including impairment of the nervous system. Illness or, in extreme cases, death may occur when a dangerous gas or liquid is breathed, taken orally or absorbed through the skin. (In general, the terms ‘toxic’ and ‘poisonous’ can be considered synonymous). Toxic substances are often ranked according to a system of toxicity ratings. One such scale is shown below:

- ***Unknown***, for products with insufficient toxicity data available.
- ***No toxicity***, for products causing no harm (under conditions of normal use) or for those that produce toxic effects only because of overwhelming dosages.
- ***Slight toxicity***, for products producing only slight effects on the skin or mucous membranes or other body organs
- ***Moderate toxicity***, for products producing moderate effects on the skin or mucous membranes or other body organs from either acute or chronic exposure.
- ***Severe toxicity***, for products that threaten life or cause permanent physical impairment or disfigurement from either acute or chronic exposure.

## **Asphyxia (suffocation)**

Asphyxia occurs when the blood cannot take a sufficient supply of oxygen to the brain. A person affected may experience headache, dizziness and inability to concentrate, followed by loss of consciousness. In sufficient concentrations any vapour may cause asphyxiation, whether toxic or not. For survival, the human body requires air having a normal content of about 21% oxygen. However, a gas-free

atmosphere with somewhat less oxygen can support life for a period without ill-effects being noticed. The susceptibility of persons to reduced oxygen levels vary but at levels below about 19%, impaired mobility and mental confusion rapidly occur. This mental confusion is particularly dangerous as the victim may be unable to appreciate his predicament. Accordingly, self-assisted escape from a hazardous location may be impossible. At levels below 16%, unconsciousness takes place rapidly and, if the victim is not removed quickly, permanent brain damage and death will result.

## **TREATMENT**

Medical treatment for exposure to gas first involves the removal of the casualty to a safe area. Where necessary it may also involve artificial respiration, external cardiac massage and the administration of oxygen.

For asphyxia and inhalation of toxic fumes Remove the casualty from the dangerous atmosphere — ensure that rescuers are equipped with self-contained breathing apparatus so that they do not become the next casualty.

To check that the patient is breathing tilt the head firmly backwards as far as it will go to relieve obstructions and listen for breathing with the rescuer's ear over the patient's nose and mouth.

### ***Patient not breathing***

- Give artificial respiration at once
- Give cardiac compression if the pulse is absent

### ***Patient breathing but unconscious***

- Place the patient in the unconscious position

- Check there are no obstructions in the mouth
- Remove any dentures
- Insert an airway; leave in place until the patient regains consciousness
- Give oxygen
- Keep the patient warm
- Give nothing by mouth
- Give no alcohol, morphine or stimulant

***Patient conscious but having breathing difficulty***

- Place the patient in a high sitting-up position and keep warm
- Give oxygen

If breathing does not improve despite these measures, then asphyxia or other lung problems may have occurred. In such circumstances, or if the patient's condition deteriorates rapidly, medical advice is required.

Oxygen resuscitators are used to provide oxygen-enriched respiration to assist in the recovery of victims overcome by oxygen deficiency or toxic gas. The equipment can be taken into enclosed spaces to give immediate treatment to a casualty. Oxygen resuscitators consist of face mask, pressurised oxygen cylinder and automatic controls to avoid damage to the victim and give audible warning in the event of airway obstructions. Oxygen must be given with care since it can be dangerous to patients who have had breathing difficulties such as bronchitis.

***Stage 1 - During rescue***

During rescue the patient should be connected to the portable oxygen resuscitation apparatus and oxygen administered until transferred to safety.

## *Stage 2 - When the patient is in a safe room*

### *The unconscious patient*

- Ensure there is a clear passage to the lungs and that an Airway is in place.
- Place mask over the nose and mouth and give 35 per cent oxygen.
- Connect the mask to the flow meter and set it at 4 liters per minute.

### *The conscious patient*

- Ask if the patient suffers with breathing difficulty. If the patient has severe bronchitis, then give only 24% oxygen. All others should be given 35% oxygen.
- The mask is secured over the patient's mouth and nose.
- The patient should be placed in the high sitting-up position.
- Turn on the oxygen flow meter to 4 liters per minute.

## **Low temperature (frostbite)**

The extreme coldness of some liquefied gases is a significant hazard. If the skin is exposed to severe cold, the tissue becomes frozen. This danger is ever-present in gas terminals and on a ship handling fully refrigerated cargos. For fully pressurised gases, while containment systems will normally be at or near ambient temperature, liquid leaks will quickly flash to the fully refrigerated temperature. Such areas should never be approached without proper protective clothing. Direct contact with cold liquid or vapour or un-insulated pipes and equipment can cause cold burns or frostbite. Inhalation of cold vapour can permanently damage certain organs (e.g. lungs).

## **TREATMENT**

- Warm the area quickly by placing it in water at 42°C until it has thawed.
- Keep the patient in a warm room.
- Do not massage the affected area.
- Severe pain may occur on thawing: give pain killer or morphine if serious.
- Blisters should never be cut, nor clothing removed if it is adhering firmly.
- Dress the area with sterile dry gauze.
- If the area does not regain normal colour and sensation, medical advice required.

## **Chemical burns**

Chemical burns can be caused by; ammonia, chlorine, ethylene oxide, propylene oxide and other certain chemical gases. The symptoms are similar to heat burns, excepting that the product may be absorbed through the skin causing toxic side-effects. Chemical burns can seriously damage the eyes. On gas carriers authorized to transport these products, deck showers and eye baths are provided for water dousing; their locations should be clearly indicated.

## **TREATMENT**

- Remove patient from source of contamination - including clothing.
- Attend first to the eyes and skin.
- Wash the eyes thoroughly for ten minutes with copious amounts of fresh water.
- Wash the skin thoroughly for ten minutes with copious amounts of fresh water.
- Cover with a sterile dressing.
- Seek urgent medical/first-aid attention.

## **BIBLIOGRAPHY**

**Liquefied Gas Handling Principles on Ships and in Terminals**, (SIGTTO) 2000. ISBN 1 85609 164 3.

**LNG Shipping Knowledge**, (SIGTTO) 2011, ISBN 978 1 85609 504 4.

**International Code for the Construction and Equipment of Ships Carrying Liquefied Gases in Bulk (IGC Code)**, 1993. IMO Ref: 104 E. ISBN 92 801 1277 5.

**Handling and Transportation of LNG**, (CHAMBER SHIPPING of British Columbia) 2016.

**Code for the Construction and Equipment of Ships Carrying Liquefied Gases in Bulk**, 1983. Incorporating Amendments 1-4, IMO Ref: 782 E. ISBN 92 801 1165 5.

**International Convention for the Safety of Life at Sea (SOLAS)**, 1974, 1992. IMO Ref: 110 E. ISBN 92 801 1294 5.

**Student Handout Material**, MARAN GAS MARITIME INC., 2012.

**Cargo Operating Manual MG Apollonia**, MARAN GAS MARITIME INC. 2014.

**Medical First Aid Guide for Use in Accidents involving Dangerous Goods (MFAG)**, 1991. IMO Ref: 251 E. ISBN 92 801 1189 2.

**International Safety Guide for Inland Navigation Tank-barges and Terminals**, (CCNR/OCIMF) 2010.

**Model Course 1.05 — Liquefied Gas Tanker Familiarisation**, 1991.

**Model Course 1.06 — Advanced Training Programme on Liquefied Gas Tanker Operations**, 1991.

**Tanker Safety Guide (Liquefied Gas)**, (ICS) 1996. ISBN 0 906270 03 0.

**Safety in Liquefied Gas Tankers**, (ICS) 1991. ISBN 0 85493 026 4.

**Guidelines for Hazard Analysis as an Aid to Management of Safe Operations**, (SIGTTO) 1992. ISBN 1 85609 054 X.

**LNG Information Paper No.1 - Basic Properties of LNG**, (GIIGNL) 2011.

**A Short History of LNG Shipping 1959-2009**, Peter G. Noble, Texas Section (SNAME), 2009.

## **INTERNET BIBLIOGRAPHY**

**<https://higherlogicdownload.s3.amazonaws.com/SNAME/1dcdb863-8881-4263-af8d-530101f64412/UploadedFiles/c3352777fcaa4c4daa8f125c0a7c03e9.pdf>** (retrieved 23/07/2017)

**[https://www.gecf.org/\\_resources/files/pages/gas-value-chain/natural-gas.jpg](https://www.gecf.org/_resources/files/pages/gas-value-chain/natural-gas.jpg)** (retrieved 23/07/2017)

**[http://www.giignl.org/sites/default/files/PUBLIC\\_AREA/About\\_LNG/4\\_LNG\\_Basics/090801publique\\_lngbasics\\_lng\\_1\\_-\\_basic\\_properties\\_7.2.09\\_aacomments.pdf](http://www.giignl.org/sites/default/files/PUBLIC_AREA/About_LNG/4_LNG_Basics/090801publique_lngbasics_lng_1_-_basic_properties_7.2.09_aacomments.pdf)** (retrieved 25/07/2017)

**<http://breakingenergy.com/2014/12/22/how-dangerous-is-lng/>** (retrieved 25/07/2017)

**[http://www.britcham.org.sg/files/event\\_document/6/6LNG%20A5%20Booklet-FINAL.compressed.pdf](http://www.britcham.org.sg/files/event_document/6/6LNG%20A5%20Booklet-FINAL.compressed.pdf)** (retrieved 30/07/2017)

**[https://www.ihrdc.com/els/po-demo/module15/figures/fig\\_018.jpg](https://www.ihrdc.com/els/po-demo/module15/figures/fig_018.jpg)** (retrieved 02/08/2017)

**<http://www.pomorskodobro.com/en/short-history-of-lng.html>** (retrieved 02/08/2017)

**<https://www.cultofsea.com/tanker/gas-tanker-types-tanks-cargo/>** (retrieved 02/08/2017)

**<http://www.cosbc.ca/index.php/references/lng-transport>** (retrieved 03/08/2017)

**<https://valueandopportunity.files.wordpress.com/2016/01/lng-containerment-tanks.jpeg?w=860>** (retrieved 03/08/2017)

**<http://www.lngworldnews.com/wp-content/uploads/2014/10/GTT-to-receive-CCS-AIP-at-LNG-seminar-in-Beijing.jpg>** (retrieved 03/08/2017)

**[http://lngseaterm.blogspot.gr/2015/01/about-shipa-virtual-tour\\_13.html](http://lngseaterm.blogspot.gr/2015/01/about-shipa-virtual-tour_13.html)** (retrieved 05/08/2017)

**[http://www.isgintt.org/files/documents/Chapter\\_30en\\_isgintt\\_062010.pdf](http://www.isgintt.org/files/documents/Chapter_30en_isgintt_062010.pdf)** (retrieved 05/08/2017)



**<https://www.km.kongsberg.com/ks/web/nokbg0240.nsf/AllWeb/E1C7040DC299F88CC12570A400338307?OpenDocument>** (retrieved 10/08/2017)

**<http://www.dh.co.kr/lng-vaporizer/>** (retrieved 10/08/2017)