

**ΑΚΑΔΗΜΙΑ ΕΜΠΟΡΙΚΟΥ ΝΑΥΤΙΚΟΥ  
ΜΑΚΕΔΟΝΙΑΣ**

**ΠΤΥΧΙΑΚΗ ΕΡΓΑΣΙΑ**

**ΕΠΙΒΛΕΠΟΥΣΑ ΚΑΘΗΓΗΤΡΙΑ: ΣΓΟΥΡΟΥ ΜΑΡΙΝΑ**

**ΘΕΜΑ**  
*The Evolution of Ship Propulsion*

**ΤΟΥ ΣΠΟΥΔΑΣΤΗ: ΕΖΑΤ ΑΛΕΞΑΝΔΡΟΣ ΟΜΑΡ**  
*A.G.M: 4184*

**Ημερομηνία ανάληψης της εργασίας: 17/05/2020**

**Ημερομηνία παράδοσης της εργασίας:**

**Ο ΔΙΕΥΘΥΝΤΗΣ ΣΧΟΛΗΣ : ΤΣΟΥΛΗΣ ΝΙΚΟΛΑΟΣ**

---

## TABLE OF CONTENTS

PROJECT SUMMARY.....	2
SPECIAL THANKS .....	2
INTRODUCTION.....	3
CHAPTER 1 – MAN POWER THE FIRST STEP .....	4
CHAPTER 2 – RIDING THE WIND .....	8
CHAPTER 3 – THE AGE OF THE STEAM ENGINE .....	17
CHAPTER 4 – STEAM ENGINES CLASSIFIED BY CONNECTION MECHANISM .....	38
CHAPTER 5 - ENTER THE STEAMSHIP-AN ERA OF FIRSTS .....	49
CHAPTER 6 – THE INTERNAL COMBUSTION ENGINE .....	70
CHAPTER 7 – THE GAS TURBINE .....	89
CHAPTER 8 – LNG ENGINE.....	90
CHAPTER 9 - HOVERCRAFTS .....	93
CHAPTER 10 - VARIOUS TYPES OF PROPELLERS AND THRUSTERS.....	94
CHAPTER 11 - CATERPILLAR.....	98
CHAPTER 12 - BIODIESEL POWERBOAT .....	99
CHAPTER 13 - ANIMAL POWER.....	100
CHAPTER 14 - NUCLEAR PROPULSION.....	101
CHAPTER 15 - THE HYDROFOIL.....	104
CHAPTER 16 - SKYSAILS PROPULSION SYSTEM .....	106
CHAPTER 17 - THE STIRLING ENGINE .....	107
CHAPTER 18 - SOLAR-POWERED PROPULSION.....	109
CHAPTER 19 - WINDMILL SHIP .....	109
CHAPTER 20 - WATER-JET PROPULSION.....	110
CHAPTER 21 - THE FLETTNER ROTOR .....	112
CHAPTER 22 - HYDROGEN PROPULSION .....	113
CHAPTER 23 - BATTERY-ELECTRIC PROPULSION .....	115
EPILOGUE .....	116
BIBLIOGRAPHY .....	117

---

## **PROJECT SUMMARY**

In this project that I have been assigned to, I will be attempting to present the stages through which marine propulsion has gone through the passage of time.

The project focuses on the advancements made in the marine propulsion systems as a whole regardless of the precise timetable or original founders of the given system due to the limitation of my research medium which is mostly the internet and books. I would also like to remark that alteration of the original events cannot be avoided, as history is usually written by the victors.

Taking into consideration these limitations I will be examining the marine propulsion systems and will be presenting some of the types thrusters, hulls and ship designs that were used in conjunction with each propulsion systems. Moreover, under the term marine propulsion I will include anything manmade in the ocean that makes way whether it be a vessel, small boat, submarine or hovercraft. I will also be including pictures to best aid with the comprehension of the given subject.

Our research will start all the way back to the oldest dugout canoe boats that date back to the Neolithic Stone Age and were propelled by man power through the use of oars.

Then we will continue through the age of sails until the era that the Steam Engines, turbines and external combustion engines took over. These were used to set propellers into motion after paddles became obsolete.

Next up we have the Gas Turbines and internal combustion engines that are able to burn marine diesel, jet fuel or in rare cases kerosene. Later on, diesel engines made their appearance along with the first diesel-electric and gas propulsion engines.

Also, around that time, dual fuel engines came along. These are basically internal combustion engines working in Diesel cycle, using liquefied natural gas (LNG) as main fuel and sometimes working in dual-fuel mode with partial marine-diesel injection.

We are going to have a look as well into the parallel evolution of thrusters. Starting from paddles, including oars and waterwheels, sails, screw propellers which are the most common even today, all the way to water jets and some miscellaneous types that will be mentioned in later chapters.

There will be reference not only to the propulsion technology that was developed but also to some of the first vessels to employ them in actual practice. So, in parallel to the technological evolution of the means of propulsion, I will be presenting the hulls that embodied them and were most notable throughout history.

## **SPECIAL THANKS**

I'd like to express my gratitude to my family for their unwavering support during this project's months of study. To the teacher with whom I was tasked with presenting my project, for assisting me with minor layout and cosmetic improvements. I am thankful for the Merchant Marine Academy of Macedonia for providing me with the opportunity to study marine history in depth and acquire experience that will benefit me for the rest of my life. Lastly, I would also like to thank the readers for taking the time to read my project.

---

## INTRODUCTION

Throughout history seafaring has been instrumental in the development of various civilizations, providing humans with greater mobility than land travel, whether for trade, transport, warfare or the capacity for fishing and leisure.

Travel at sea is the easiest compared to land transport, a log floats and is carried with the current, no hills to climb, no thick vegetation to be pushed aside... But, to get where we want to, we need propulsion, and fluid propulsion is by far more difficult than land propulsion.

The reason for this difficulty is that, for us to advance, we need to push something backwards (propulsion fundamentals) and it is far more efficient to push a massive object (the Earth) back by solid-friction forces at our feet (or by wheels), than to push a small amount of fluid back over and over again (the mass of water you can take in with your hands, or with oars, propeller).

Propulsion is the action or process of pushing or pulling to drive an object forward. The term is derived from two Latin words: pro, meaning before or forward; and pellere, meaning to drive.

Propulsion in vessels is needed not only to go ahead against natural forces (water and air drag), but also to decelerate and stop and even keep the current position on the surface or under water. Without propulsion, a surface ship cannot steer (all rudders work only dynamically) and underwater, without propulsion it is almost impossible to keep a fixed depth of immersion simply by buoyancy. Of course, crawling propulsion can be used to move along the sea floor, but this solution is a rarity because of the muddy bottom of the oceans.

A propulsion system consists of three parts: an energy source (carried aboard as animal or fuel energy, or collected from outside such as wind or solar power), an engine that transforms that energy into a mechanical form, and the propulsor or thruster (that pushes the surrounding water backwards).

A technological system uses an engine or motor as the power source (commonly called a powerplant) and wheels, axles, propellers, or a propulsive nozzle to generate the force. Components such as clutches or gearboxes may be needed to connect the motor to axles, wheels, or propellers. A technological/biological system may use human, or trained animal muscular work to power a mechanical device.

It's a known fact that sea transport has been the largest carrier of freight all throughout history because it is the cheapest way. When we combine that fact with the realization that a substantial portion of every military's strength is derived from its naval fleet, we may conclude that a great deal of focus has been placed on improving the construction of the numerous ships both in merchant and military practices.

Thus, with each substantial technological leap in the propulsion system, what usually follows is a corresponding improvement on the hull configuration of the vessel that employs it and is worth looking into.

---

## CHAPTER 1 – MAN POWER THE FIRST STEP

In this section vessels that have rowing as a primary means of propulsion will be included, regardless of them using sails as a secondary means of propulsion.

### 1.1 - Introduction

Maritime history dates back thousands of years. In ancient maritime history, evidence of maritime trade between civilizations dates back at least two millennia. The first prehistoric boats are presumed to have been dugout canoes which were developed independently by various Stone Age populations. These boats that featured various styles were used for coastal fishing and small distance travels.



*Dugout Canoe – reconstruction*

### 1.2 – Types of oar vessels

#### Dugout Canoes

*Dugout Canoes*, are the oldest boat type archaeologists have found. They are made of massive pieces of wood, which are made from hollowed tree trunks. Along with bark canoe and hide kayak, dugout boats were also used by indigenous people of America.

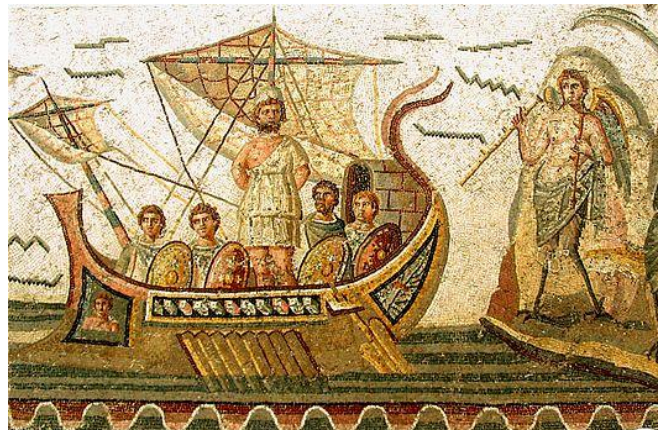

*Early depiction of a Dugout Canoe*

They belonged in the same category with Egyptian boats which commonly featured sails as well as oars.

Due to the fact that they were confined to the Nile and depended on winds in a narrow channel, recourse to rowing was essential. This became true of most navigation when the Egyptians began to venture out onto the waters of the Mediterranean and Red seas. Most initial Nile boats had a single square sail as well as one row of oarsmen. Quickly, several levels-rows came into use, as it was difficult to maneuver very elongated boats in the open sea.



*Egyptian Dugout Canoe*

---

## Reed boats

Often used as traditional fishing boats, they are still used in a few places around the world, even though they have been replaced with planked boats. Reed boats can be distinguished from reed rafts, since reed boats are usually waterproofed with some form of tar. The earliest discovered remains of a reed boat are 7000 years old, found in Kuwait. They are depicted in early petroglyphs and were most common in Ancient Egypt.



*Traditional Reed boat – Reconstruction*

They are still used in Peru, Bolivia, Ethiopia and until recently in Corfu.

## The Galley

A galley is a type of ship that is propelled mainly by rowing. The galley is characterized by its long, slender hull, shallow draft, and low freeboard (clearance between sea and railing). Virtually all types of galleys had sails that could be used in favorable winds but human effort was always the primary method of propulsion. This allowed galleys to navigate independently of winds and currents. The galley originated among the seafaring civilizations



*The Galley - 3d render*

around the Mediterranean Sea including the Greeks, Illyrians, Phoenicians, and Romans in the late second millennium BC and remained in use in various forms until the early 19th century in warfare, trade, and piracy.

---

## The Trimere

*Trireme*, an oar-powered warship that reached its highest point of development in the eastern Mediterranean during the 5th century BCE.

Light, fast, and maneuverable, it was the principal naval vessel with which Persia, Phoenicia, and the Greek city-states fought for mastery of the seas from the Battle of Salamis in 480 BCE through the end of the Peloponnesian War in 404.

The light materials that were used for its construction and the strength of the oarsmen allowed the Trireme to travel at high speed which combined with its battering ram could inflict devastating damage on the enemy ships.



*The Trireme*

## Leontophoros

*Leontophoros* was a famous ship built in Heraclea for Lysimachos, one of the largest wooden ships ever built. In this ship there were eight hundred men from each side. From both sides there were one thousand six hundred oarsmen in total.

Those who fought from the deck were one thousand two hundred and there were two helmsmen as well. Using the data provided by Vitruvius on the space allowed for each oarsman, Morrison concluded that the ship was at least 110m long.

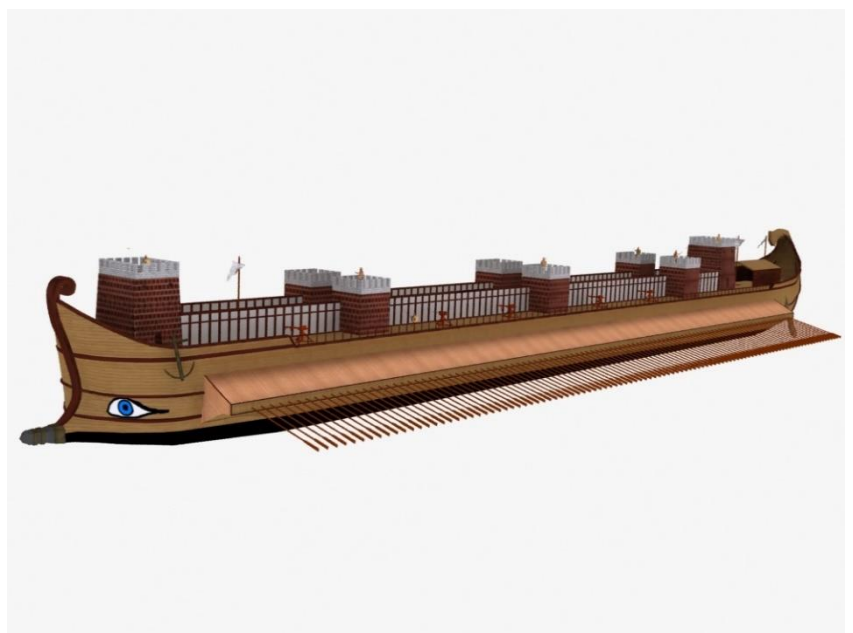

*Leontophoros - 3d render*

---

## The Bimere

A *bireme* is an ancient oared warship with two decks of oars. Bimeres were long vessels built for military purposes and could achieve relatively high speeds. They were invented well before the 6th century BC and were used by the Phoenicians, Assyrians & Greeks. One bimere was typically about 24m long with a maximum beam width of around 3m.



*The Phoenician Bimere - reconstruction*

## Tessarakonteres

*Tessarakonteres* or simply "forty" was a very large catamaran galley reportedly built in the Hellenistic period by Ptolemy IV Philopator of Egypt. As a catamaran of two "twenties" with 4,000 oarsmen, there would be 2,000 per hull and therefore 1,000 per side. It had a length of 130 meters.

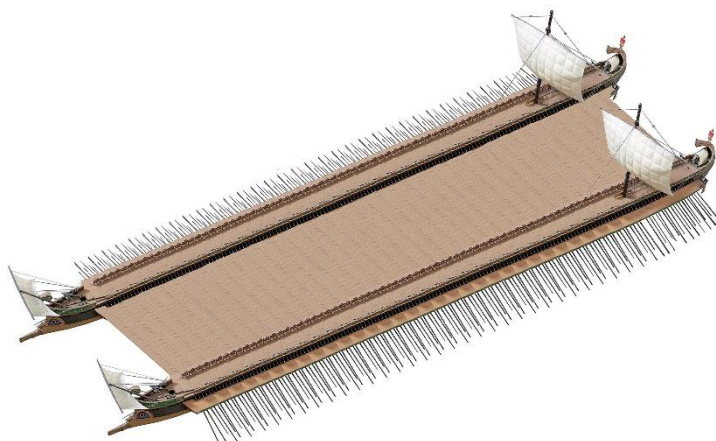

*Tessarakonteres – 3d render*

## Longship

The *longships* were characterized as elegant, long, wide and light, with a shallow-draft hull designed for speed. They demonstrated true individual designs with its designer's footprints and often had regional characteristics. For example, the choice of material was mostly dictated by the regional forests, that is pine from Norway and Sweden, and oak from Denmark.



*Small sized longship*



---

## CHAPTER 2 – RIDING THE WIND

### 2.1 - Introduction

The move to the pure sailing ship came with small but steadily increasing technical innovations that allowed ships to sail with the wind behind them. Sails changed from a large square canvas suspended from a single yard (top spar), to complex arrangements intended to pivot on the mast depending on the direction and force of the wind. Instead of being driven solely by the wind direction, ships could “sail into the wind” to the extent that the course taken by a ship became the product of a resolution of forces (the actual wind direction and the objective course of the particular ship). Sails were devised to handle gentle breezes and to gain some mileage from them as well as from strong winds and to maintain some choice as to course while under their influence.

### 2.2 – Sails and masts

While the speed of a rowed ship was mainly determined by the number of oarsmen in the crew, in sailing ships the total spread of canvas in the sails was the main determinant of speed. Because winds are not fixed either as to direction or as to force, gaining the maximum effective propulsion from them requires complexly variable sails. There was one constant that characterized navigation by sail throughout its history, to gain speed it was necessary to increase the number of masts on the ship.

Ships in both the Mediterranean and the north were single-masted until about 1400 BC and likely as well to be rigged for one basic type of sail. With experience square sails replaced the simple lateen sails that were the mainstay during the Middle Ages, particularly in the Mediterranean.

By 1200 AD the standard sailing ship in the Mediterranean was two-masted, with the foremast larger and hung with a sail new to ordinary navigation at sea. This was the lateen sail, earlier known to the Egyptians and sailors of the eastern Mediterranean. The lateen sail (as shown in the figure) is triangular in shape and is fixed to a long yard mounted at its middle to the top of the mast. The combination of sails tended to change over the years, though the second mast often carried a square sail.

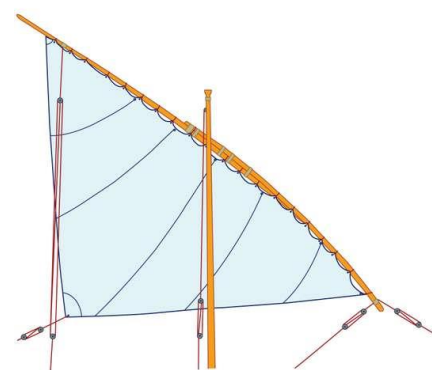
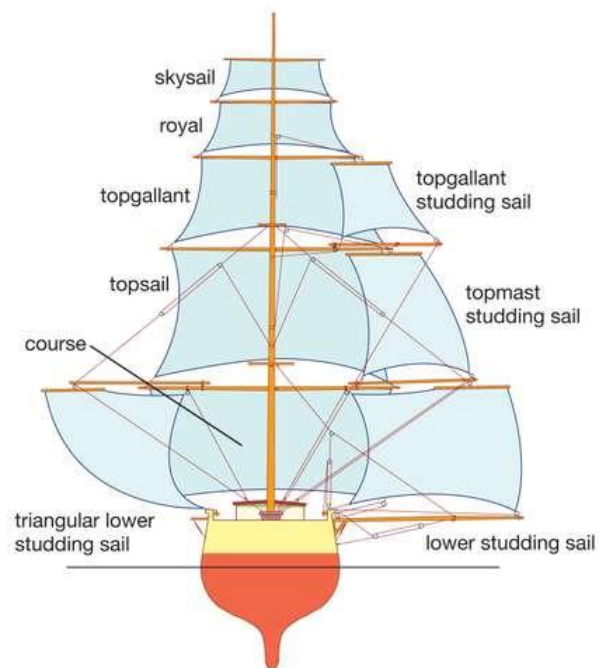

*The Lateen Sail*

For ships with square sails the principal masts, given their standard names in bow to stern (front to back) order, are:

- **Staysail:** it is a fore-and-aft rigged sail whose luff can be affixed to a stay running forward (and most often but not always downwards) from a mast to the deck, the bowsprit, or to another mast
- **Fore-mast:** the mast nearest the bow, or the mast forward of the main-mast with sections: fore-mast lower, fore topmast, and fore topgallant mast
- **Main-mast:** the tallest mast, usually located near the centre of the ship with sections: main-mast lower, main topmast, main topgallant mast, royal mast (sometimes)
- **Mizzen-mast:** the aft-most mast. Typically, shorter than the fore-mast with sections: mizzen-mast lower, mizzen topmast, and mizzen topgallant mast.
- **Jigger-mast:** typically, it is the shortest and aftmost mast on vessels with more than three masts
- **Fore-and-aft rig:** it is a sailing rig that has sails that are set along the line of the keel instead of perpendicular to it. Such sails are described as fore-and-aft rigged.

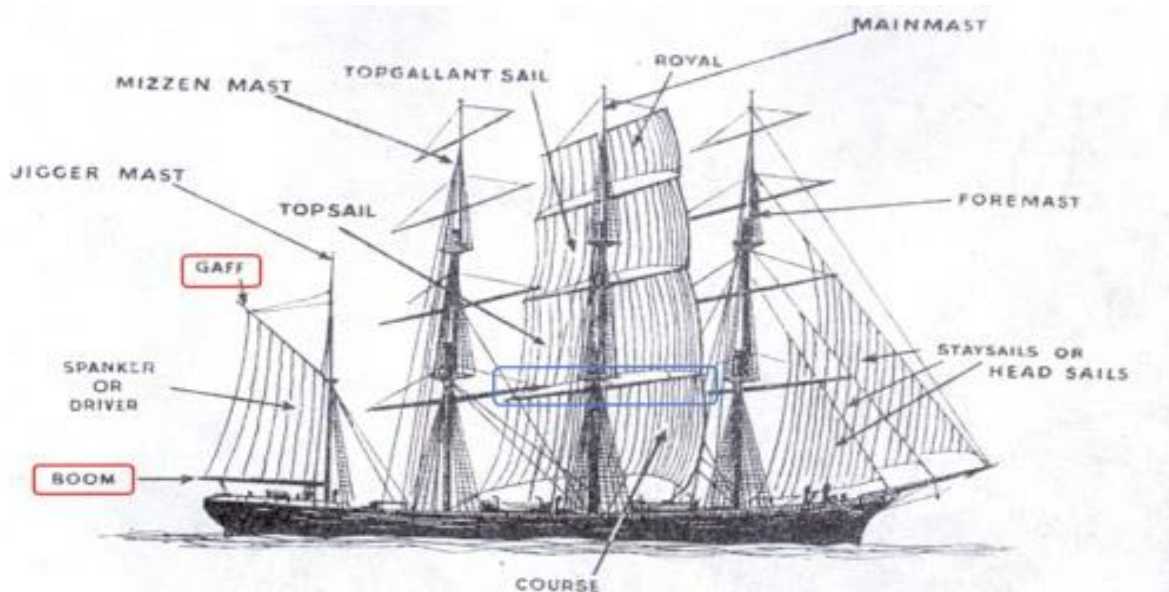

- 1) **Barque:** at least three masts, fore-and-aft rigged mizzen mast
- 2) **Barquentine:** at least three masts with all but the foremost fore-and-aft rigged
- 3) **Fully Rigged:** Square rigged with three or more masts casually called a ship
- 4) **Brigantine:** two masts, with the foremost square-rigged
- 5) **Brig:** two masts, square rigged (may have a spanker on the aftermost)
- 6) **Schooner:** fore-and-aft rigged sails, with two or more masts
- 7) **Sloop:** single mast with one fore headsail and one mainsail aft

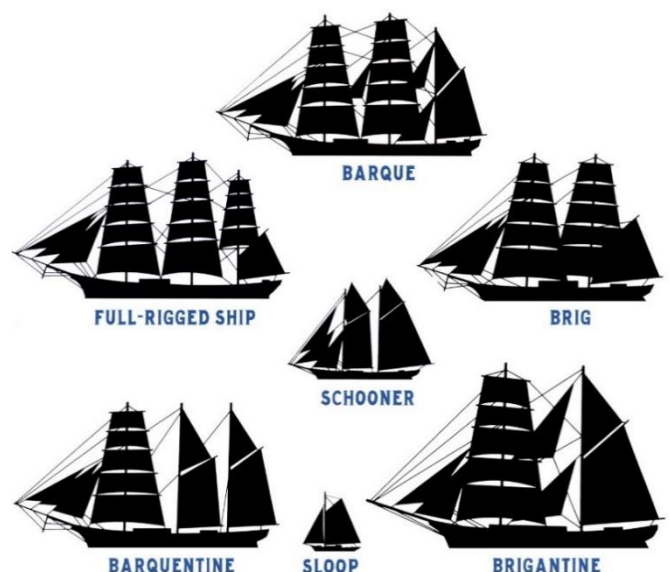

---

## 2.3 - Asian ships

During this same period China, with its vast land areas and poor road communications, was turning to water for transportation. Starting with a dugout canoe, the Chinese joined two canoes with planking, forming a square punt, or raft. Next, the side, the bow, and the stern were built up with planking to form a large, flat-bottomed wooden box. The bow was sharpened with a wedge-shaped addition below the waterline. At the stern, instead of merely hanging a steering oar over one side as did the Western ships,

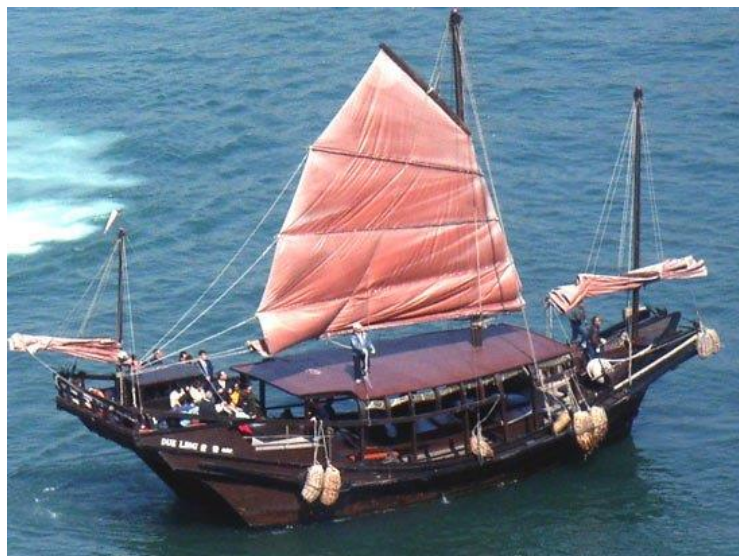

*Modern Chinese Junk - Attraction*

Chinese shipbuilders contrived a watertight box, extending through the deck and bottom, that allowed the steering oar or rudder to be placed on the centreline, thus giving better control. The stern was built to a high, small platform at the stern deck, later called a castle in the West, so that, in a following sea, the ship would remain dry. Thus, in spite of what to Western eyes seemed an ungainly figure, the Chinese junk was an excellent hull for seaworthiness as well as for beaching in shoal (shallow) water. The principal advantage, however, not apparent from an external view, was great structural rigidity. In order to support the side and the bow planking, the Chinese used solid planked walls (bulkheads), running both longitudinally and transversely and dividing the ship into 12 or more compartments, producing not only strength but also protection against damage.

In rigging the Chinese junk was far ahead of Western ships, with sails made of narrow panels, each tied to a sheet (line) at each end so that the force of the wind could be taken in many lines rather than on the mast alone; also, the sail could be hauled about to permit the ship to sail somewhat into the wind. By the 15th century junks had developed into the largest, strongest, and most seaworthy ships in the world. Not until about the 19th century did Western ships catch up in performance.



*Chinese Junk - 3 masts*

---

## 2.4 - Early oceanic navigation

The rise of oceanic navigation began when the basic Mediterranean trading vessel, the Venetian buss (a full-bodied, rounded two-masted ship), passed through the Strait of Gibraltar. At the time of Richard I of England (reigned 1189–99), whose familiarity with Mediterranean shipping stemmed from his participation in the Crusades, Mediterranean navigation had evolved in two directions: the galley had become a rowed fighting ship and the buss a sail-propelled trader's vessel. From Richard's crusading expeditions the value of the forecastle and aftercastle—giving enclosed deck houses and a bulging bow of great capacity—was learned, and this style became the basis of the English oceangoing trader. These crusading voyages also introduced the English to journeys longer than the coasting and North Sea navigation they had previously undertaken.

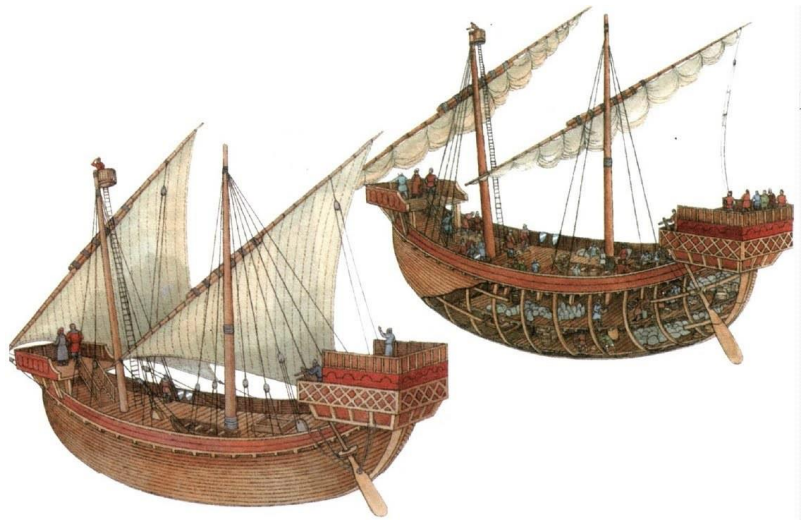

*The Galley*

## 2.5 - 15<sup>th</sup> Century Ships and shipping

The early 15th century saw the rise of the full-rigged ship, which had three masts and five or six sails. At the beginning of that century Europe and Asia were connected by caravan routes over land. The galleys or trade ships were long, low-sided. By the end of the century Da Gama, Columbus, and Cabot had made their revolutionary journeys, the Portuguese had organized the first school of oceanic navigation, and trade had begun to be global.

“Full-rigged” ships were introduced because trade was becoming larger in scale, more frequent in occurrence, and more distant in destination. The only way to enlarge the propulsive force was to pack more square yards of canvas on a hull, which required multiple masts and hoisting more and larger sails on each mast. As multiple masts were added, the hull was elongated, keels were often two and a half times as long as the ship's beam (width). At the beginning of the 15th century large ships were of about 300 tons; by 1425 they were approximately 720 tons.



*Illustration depicting Christopher Columbus's fleet departing from Spain in 1492.*

---

## 2.6 – 16<sup>th</sup> Century Sailing

In the 16th century the full-rigged ship was initially a carrack, a Mediterranean three-master. The mainmast and foremast were rigged with square sails and the mizzenmast rigged with a fore-and-aft triangular lateen sail. It was first introduced from Genoa to England.

The trade between the Mediterranean and England was carried on at Southampton largely by these carracks.



*Mediterranean Carrack*

As the years passed, the galleon became the most distinctive vessel. This was most commonly a Spanish ship riding high out of the water.

Although the name suggested a large galley, galleons didn't carry oars and were three or four masted, square-rigged, multi decked sailing ships used for war or commerce. They were lightly armed with cannons in general.



*Spanish Galleon*

---

## 2.7 – 17<sup>th</sup> Century Developments

With the emergence of the eastern trade about 1600 the merchant ship had grown impressively. The Venetian buss was rapidly supplanted by another Venetian ship, the cog. A buss of 240 tons with lateen sails was required by maritime statutes of Venice to be manned by a crew of 50 sailors. The crew of a square-sailed cog of the same size was only 20 sailors. Thus, began an effort that has characterized merchant shipping for centuries—to reduce crews to the minimum. This was particularly true of oceanic navigation, because larger crews were expensive to pay and to provision—and the large amounts of provisions necessary were sometimes critical on long voyages.



*Venetian Cog - drawing*

Raleigh wrote that the Dutch ships of the period were so easy to sail that a crew one-third the size used in English craft could operate them. Efforts were made to accomplish technical improvements on English copies of Venetian and Genoese traders. These ultimately resulted in the East Indiaman of the 17th century. This large and costly ship was intended to be England's entry in a fierce competition with the Dutch for the trade of India and the Spice Islands.



*East Indiaman*

The Dutch competitors of England were able to build and operate merchant ships more cheaply. In the 16th century the sailing ship in general service was the Dutch fluyt, which made Holland the great maritime power of the 17th century. A long, relatively narrow ship designed to carry as much cargo as possible, the fluyt featured three masts and a large hold beneath a single deck. The main and fore masts carried two or more square sails and the third mast a lateen sail. Only at the end of the century,

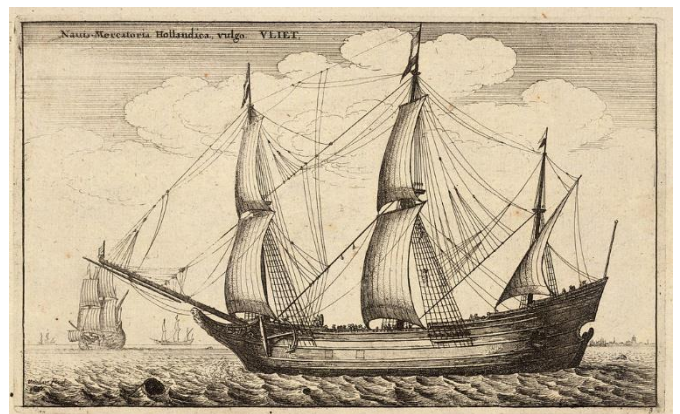

*Dutch Fluyt*

when the Dutch had been decisively defeated in the Anglo-Dutch trading wars, did England finally succeed to the role of leading merchant marine power in the world and possessed the largest merchant marine until it lost that distinction to the Americans in the mid-19th century.

---

## 2.8 - Copper Sheathing

During the Age of Sail, ships' hulls were under frequent attack by shipworms (which affected the structural strength of timbers), barnacles and various marine weeds (which affected ship speed). Since before the common era, a variety of coatings had been applied to hulls to counter this effect, including pitch, wax, tar, oil, sulfur and arsenic. In the mid-18th century copper sheathing was developed as a defense against such bottom fouling, similar function to the modern anti-fouling paint. After coping with problems of galvanic deterioration of metal hull fasteners, sacrificial anodes were developed, which were designed to corrode, instead of the hull fasteners. The practice became widespread on naval vessels, starting in the late 18th century, and on merchant vessels, starting in the early 19th century, until the advent of iron and steel hulls.

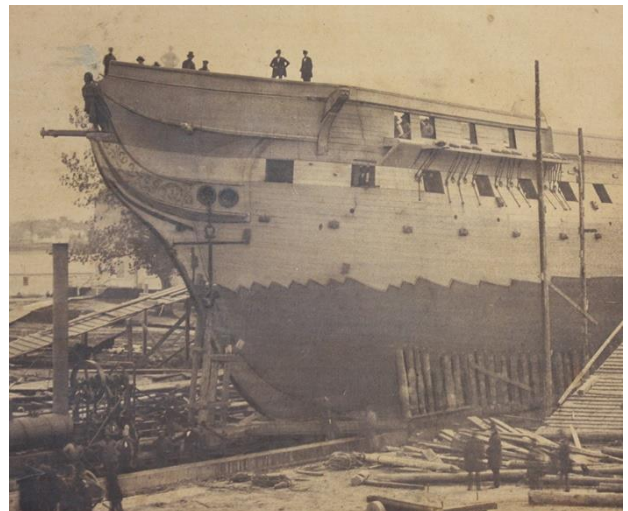

*Copper Sheathing in a dry dock*

## 2.9 - Shipping in the 19th century

Once the extent and nature of the world's oceans was established, the final stage of the era of sail had been reached. The American independence played a major role in determining how the final stage developed.

In the 25 years after 1815 American ships changed in weight from 500 to 1,200 tons and in configuration from a hull with a length 4 times the beam. The faster and thus shorter journeys meant that the shipowner could earn back his investment in two or three years. The *Mayflower* had taken 66 days to cross the Atlantic in 1620. The Black Ball Lines' nine-year average as of 1825 was 23 days from Liverpool to New York City. Twenty years later Atlantic ships had doubled in size and were not credited as a success unless they had made at least a single east-bound dash of 14 days or less.



*The Mayflower*

The culmination of these American innovations was the creation of a hull intended primarily for speed, which came with the clipper ships. *Clippers* were long, graceful three-masted ships with projecting bows and exceptionally large spreads of sail. The first of these, the *Rainbow*, was built in New York in 1845. It was followed by a number of ships built there and in East Boston particularly intended for the China-England tea trade, which was open to all merchant marines by the late 1840s.



*Standard Clipper type vessel*

---

Subsequently the *Witch of the Wave* (an American clipper) sailed from Canton to Deal, England, in 1852 in just 90 days. Similar feats of sailing were accomplished in Atlantic crossings. In 1854 the *Lightning* sailed 436 miles in a day, at an average speed of 18 1/2 knots.

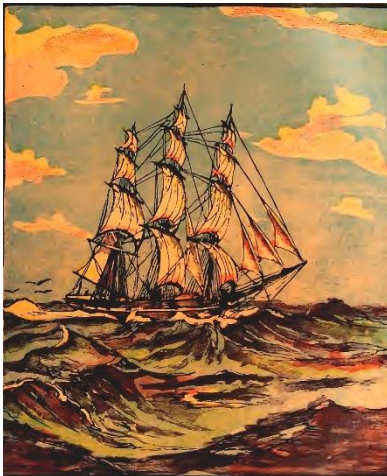

*Rainbow*



*Witch of the wave*

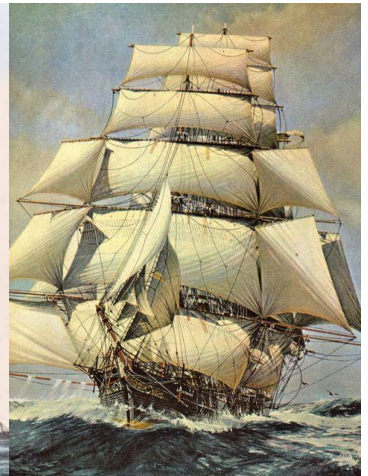

*Lightning*

## 2.10 - The End of the Glorious Sailing Era

Iron-hulled sailing ships, often referred to as "windjammers" or "tall ships", represented the final evolution of sailing ships at the end of the Age of Sail. They were built to carry bulk cargo for long distances in the nineteenth and early twentieth centuries. They were the largest of merchant sailing ships, with three to five masts and square sails, as well as other sail plans. They carried lumber, ore or grain between continents. Later examples had steel hulls.



*Standard Windjammer type vessel*

The four-masted, iron-hulled ship, introduced in 1875 with the full-rigged *County of Peebles*, represented an especially efficient configuration that prolonged the competitiveness of sail against steam in the later part of the 19th century.



*County of Peebles*



---

The largest example of such ships was the five-masted, full-rigged ship *Preussen*, which had a load capacity of 7,800 tonnes. Ships transitioned from all sail to all steam-power during from the mid-19th century into the 20th. Five-masted *Preussen* used steam power for driving the winches, hoists and pumps, and could be manned by a crew of 48, compared with the four-masted *Kruzenshtern*, which has a crew of 257.

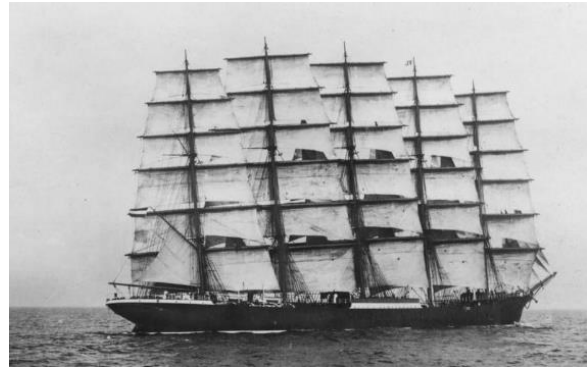

*Preussen*

Even into the twentieth century, sailing ships could hold their own on transoceanic voyages such as Australia to Europe, since they did not require bunkering for coal nor fresh water for steam and they were faster than the early steamers, which usually could barely make 8 knots.



*Kruzenshtern*

By 1840, however, it was clear that the last glorious days of the sailing ship were close at hand. Iron-hulled sailing ships were mainly built from the 1870s to 1900, when steamships began to outpace them economically, due to their ability to keep a schedule regardless of the wind. Steel hulls also replaced iron hulls at around the same time. Pure sailing ships were in active use for another generation, while the earliest steamships were being launched. By 1875 the pure sailer was disappearing, and by the turn of the 20th century the last masts on mainstream passenger ships had been removed.

---

## CHAPTER 3 – THE AGE OF THE STEAM ENGINE

### 3.1 – Introduction

Following the end of the mainstream sailing era, the trend of technological development that followed was:

1. Development of ships propelled by *steam engines* driving paddle wheels.
2. Development of the *screw propeller* to replace the paddle wheel driven by a steam engine.
3. Development of the *diesel engine* to replace the steam engine.
4. Development of the *steam turbine* in order to achieve the higher rotative speeds.

Although, the above gives the developments in point form, it is not a chronological representation of the actual developments. Different engineers or researchers were experimenting in different places, yet, at the same time. Some became successful while others failed, but the combined effort resulted in what is now the most popular form of propulsion “**The screw propeller**”.

### 3.2 – Paddle Wheels

*Paddles* came onto the scene with the discovery of properties of steam and the developments in the Newcomen Engine. These were driven by the steam engine, and were largely made up of wooden spirals/planks riveted around a large wheel mounted on the sides of the ship. Initially the paddles were a series of oars, which were arranged around on a framework and worked by a mechanism to give them the to and -fro movement. Obviously, this was not very effective and the oars took up most of the space in the engine room. The development of rotary paddles mounted on the side of the vessel, came as an improvement as it allowed larger and multiple engine cylinders to be used. Some of the early vessels had the paddles placed at the stem with the engine on deck, or ‘quarter-wheels’ (one on each side of the stem), with the engine and boiler in the hold. It should be noted that most of the ships were designed as sailing ships. The paddles and their engines were only for assistance if the wind failed. Therefore, it was common practice and knowledge that the engine wasn't run continuously. The only exception was a popular belief that, the paddle ships had to continue running their engines in a storm as it improved the ship's stability and sea keeping capabilities.



*Modern recreational vessel with a paddle wheel*

### 3.3 – The Screw Propeller

The Screw propeller was not very well known in the first half of the nineteenth century. The first scientist seen to be popular with the propeller, was Colonel John Stevens an American, who designed a screw driven ship in 1804. The race for this new innovation continued and several ships were fitted and driven by the screw propeller.

---

Problems associated with the screw propeller were:

- Rotational speed which was very slow due to low pressure from the boilers. In order to achieve high speed, it required high pressure steam and this wasn't achieved until 1860.
- No propeller gearing equipment to upgrade the speed from that of low steam engine.
- The absorbing of the propeller thrust into the ship's hull 'thrust block' by then, was not yet developed (extra support to limit the axial movement of the shaft).
- With direct drive coupling the propeller shaft to the intermediate shaft resulted in transmission to the crankshaft bearing, resulting in overheating and problems of lubrication.
- Finding a suitable means of providing an underwater fitting in the ship's hull for the main shaft 'stern tube'. The solution was the development of the stern tube with lignum vitae bush (material) in 1854. Lignum Vitae (Tree of life), is the world's densest wood and in addition to being strong, hard, heavy, dense, water and salt-water-resistant, it contains natural oils that make the bearings self-lubricating.

The success story of the screw propeller came in later years. Starting with the Archimedes experiments and Brunel adoption of the ideas, as employed on the Great Britain and the Great Eastern. The screw propeller had found its mark, and it was there to stay.

Other developments in the screw propeller were:

- Fitting of twin-screw propulsion
- Gearing to adopt various speed requirements
- Optimization of number of blades
- Improvements of the underwater fitting arrangements

As the ship sizes increased, the size of the propeller became also larger, in order to absorb the new power requirements.



*The screw propeller*

### 3.4 – The Steam Engine

A steam engine is a heat engine that performs mechanical work using steam as its working fluid. The steam engine uses the force produced by steam pressure to push a piston back and forth inside a cylinder. This pushing force is transformed, by a connecting rod and flywheel, into rotational force for work.

The term "steam engine" is generally applied only to reciprocating engines as just described, not to the steam turbine. Steam engines are external combustion engines, where the working fluid is separated from the combustion products.

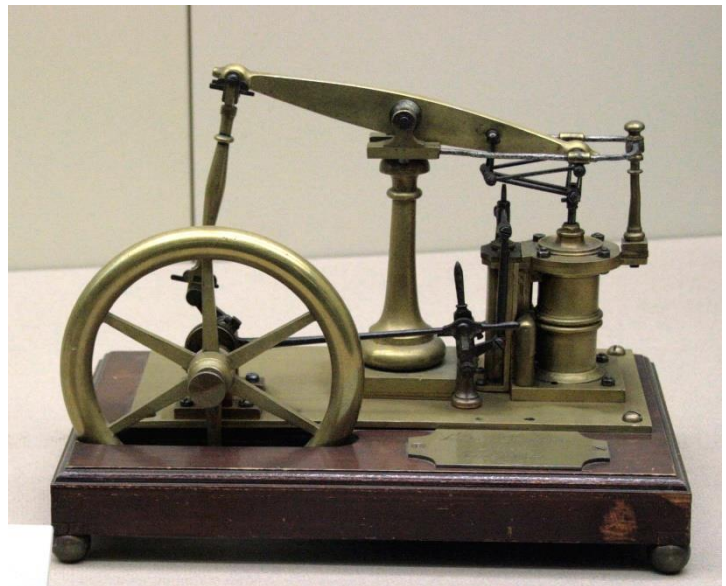

Model of a Beam Steam engine

### 3.5 - Thomas Savery Steam Pump

The story of the marine engine goes back 150 years. It is most attributed to the development of steam and its physical properties.

The founder of the steam engine 'Thomas Savery, (1698), was the first to develop the first machinery-pump that worked continuously, pumping water from a mine sump and delivering it from 80 feet (24.4 m) and in his words he provided an "engine to raise water by fire".

The Savery Pump was extensively popular for use in the mines and was the most required tool sometimes known as "friend of the miner". Fuel consumption was about 30 lb/13.6 kg of coal per hp.

Water will rise up about 33 feet in a laboratory vacuum. Savery's device was limited in practical usage to 20-25 feet of suction. Therefore, the pump needed to be located within about 25 feet of the water. Imagine the difficulties of placing a boiler with a raging fire down in a deep well!

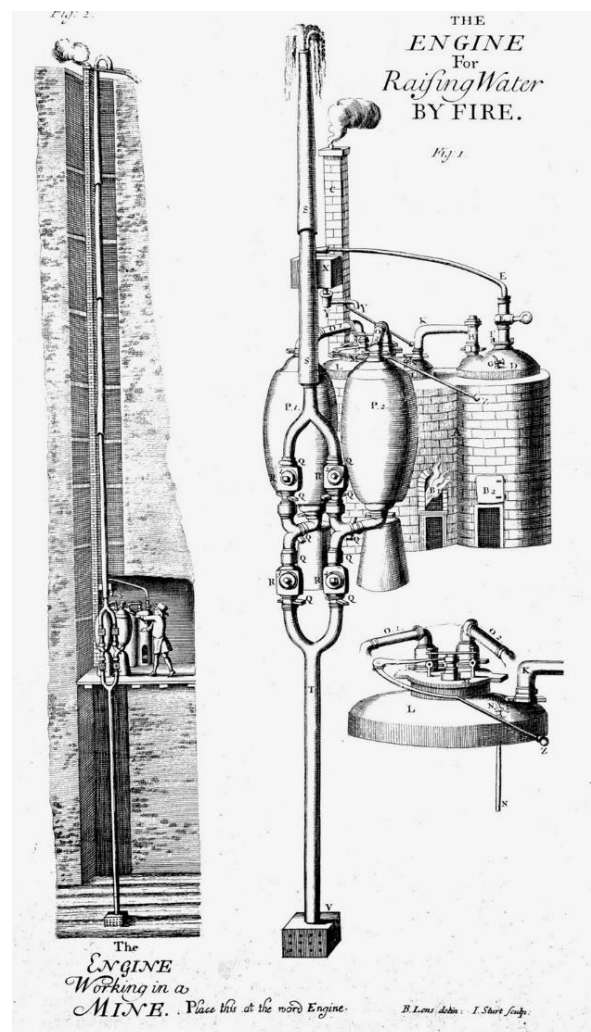

Thomas Savery's Engine

Operation of the pump was by admitting steam to one side of the cylinder. The steam would force the water in the cylinder out through the discharge chamber. The steam would then be shut off. Upon condensation a vacuum would be created and water would enter the chamber through the valves from the well to replace the already discharged steam.

Then, when the steam is admitted, the water would be forced out through the valve chest thus repeating the cycle. The other side of the cylinder is operated in the same way hence duplicating the amount of water discharged. Thus, the arrangement is a double pump.

One of the main drawbacks of the pump was in its operation, that it required an attendant to operate the steam valve with careful manipulation. The steam drums were very hot so the water level could not be judged correctly.

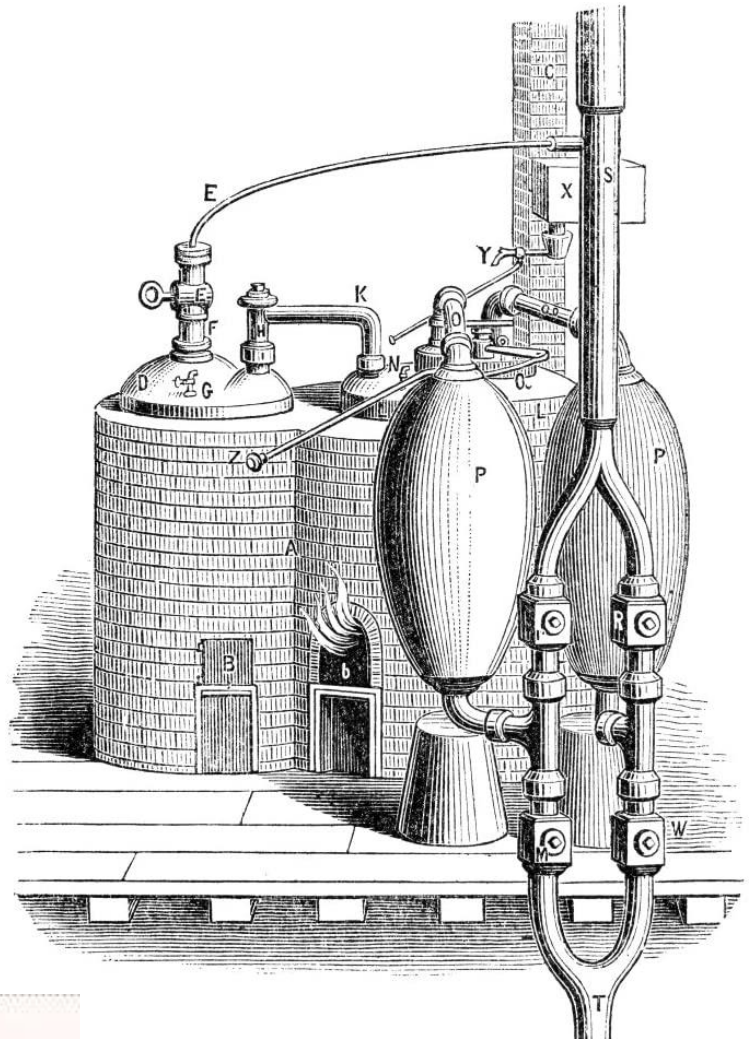

*Another view at Tomas Savery's pump*

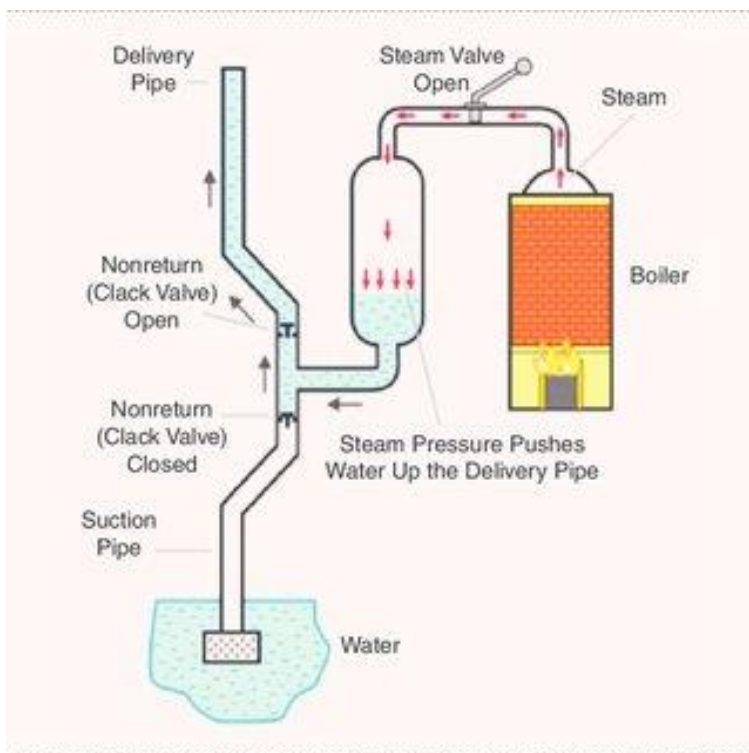

*Explanation diagram*

Obviously, the skills of the operator were required to:

- i. determine length and duration of stroke for the most efficient delivery
- ii. minimize the steam intake per stroke
- iii. ascertain the quantity of steam being discharged together with water.

### 3.6 – Newcomen Engine

Thomas Newcomen developed the Thomas Savery idea and came up with the picklepot condenser in 1705 which later became operational and became known as the fire engine/ Newcomen engine in 1712 . This engine raised the depth of water to be pumped and the pump itself was made to be self-acting. The depth of pumping water to the surface was increased from 80 feet to 500 feet (24m - 154 m) almost over a 600 % increase.

Despite the success achieved in the depth of the mines drawbacks still existed:

- It was operating on atmospheric boiler steam pressure which was too low
- Working pressure had to be brought from cold, losing thermal heat in the process (the solution was to condense the steam separately without cooling the main cylinder later done by James Watt)

The pump equipment F was heavier than the steam piston D, so that the position of the beam at rest was pump-side down/engine-side up, which was called "out of the house".

To start the engine, the regulator valve V was opened and steam was admitted into the cylinder from the boiler, filling the space beneath the piston. The regulator valve was then closed and the water injection valve V' briefly snapped open and shut, sending a spray of cold water into the cylinder B.

This condensed the steam and created a partial vacuum under the piston. Pressure differential between the atmosphere above the piston and the partial vacuum below then drove the piston down making the power stroke, bringing the beam "into the house" and raising the pump gear. Steam was then readmitted to the cylinder, destroying the vacuum and driving the condensate down the sinking or "eduction" pipe E. As the low-pressure steam from the boiler flowed into the cylinder, the weight of the pump and gear returned the beam to its initial position, whilst at the same time driving the water up from the mine.

This cycle was repeated around 12 times per minute. Lastly, with the plug tree connected to the beam action, Newcomen was able to automate the operation of the opening and closing of valves instead of using a human plugman/valveman.

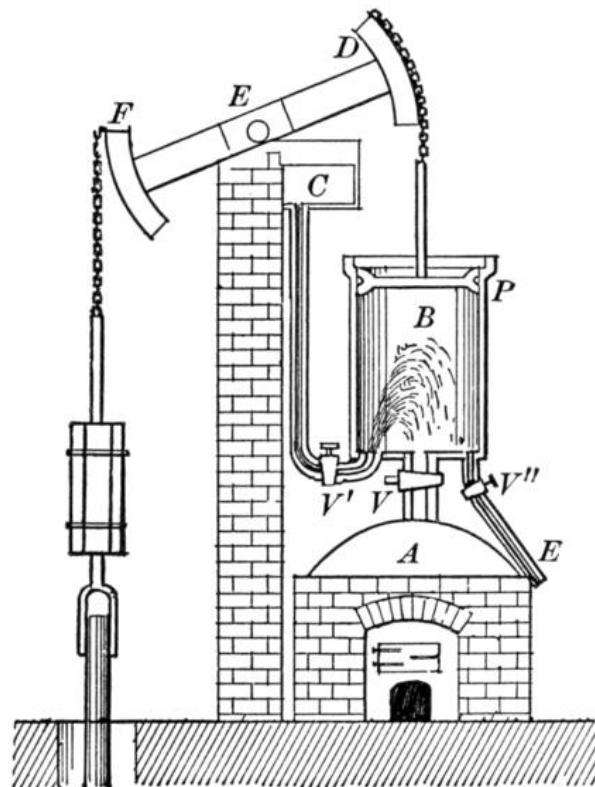

*Newcomen's Engine*

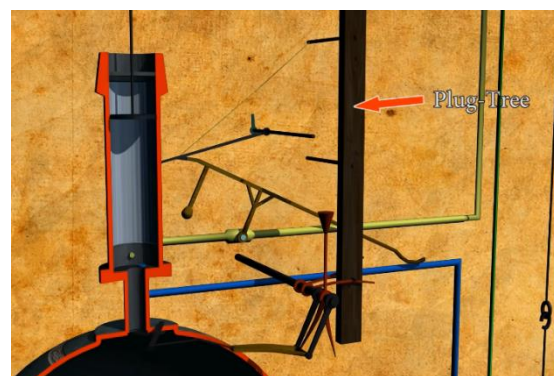

*Plug Tree*

### 3.7 – James Watt Engines

While working at the University of Glasgow as an instrument maker and repairman in 1759, James Watt was introduced to the power of steam by Professor John Robison. When Watt discovered that the University owned a small working model of a Newcomen engine, he insisted to have it returned from London where it was being unsuccessfully repaired. Watt repaired the machine, but found it was barely functional even when fully repaired.

Limitations and draw backs of the Newcomen engine, as discovered and improved by James Watt were:

- high fuel consumption, in which the cure was designing a separate condenser, air pump and lagged cylinder
- use of steam in a cylinder to push the piston
- create a vacuum underneath the piston

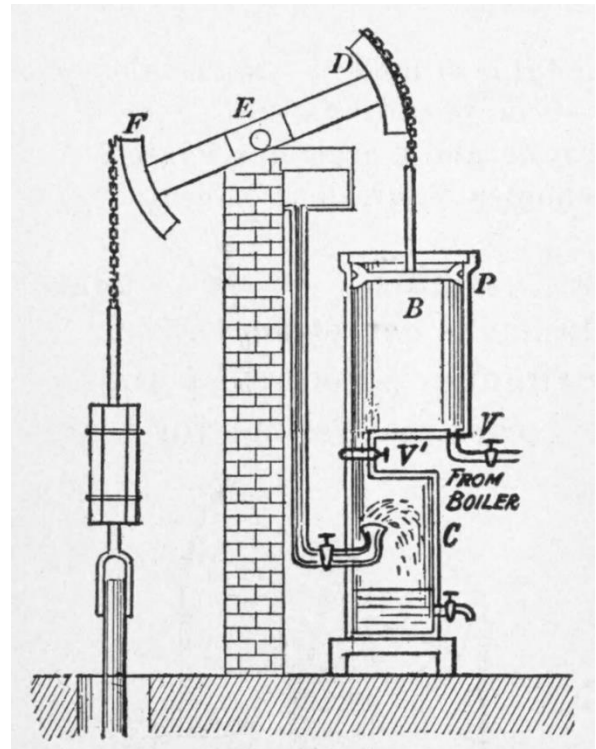

Watt's Steam condenser Engine

After working with the design, Watt concluded that 80% of the steam used by the engine was wasted. Instead of providing motive force, it was instead being used to heat the cylinder. In the Newcomen design, every power stroke was started with a spray of cold water, which not only condensed the steam, but also cooled the walls of the cylinder. This heat had to be replaced before the cylinder would accept steam again.

In the Newcomen engine the heat was supplied only by the steam. Therefore, when the steam valve was opened again, the vast majority condensed on the cold walls as soon as it was admitted to the cylinder. It took a considerable amount of time and steam before the cylinder warmed back up and the steam started to fill it up.

Watt solved the problem of the water spray by removing the cold water to a different cylinder C. This type of condenser is known as a *jet condenser*. The condenser is located in a cold-water bath below the cylinder. Once the induction stroke was complete a valve V' was opened between the two, and any steam that entered the cylinder would condense inside this cold cylinder C. This would create a vacuum that would pull more of the steam into the cylinder, and so on until the steam was mostly condensed. The valve V' was then closed, and operation of the main cylinder continued as it would on a conventional Newcomen engine. As the power cylinder B remained at operational temperature throughout, the system was ready for another stroke as soon as the piston was pulled back to the top.

Maintaining the temperature was a jacket around the cylinder where steam was admitted. Watt produced a working model in 1765. Not content with this single improvement, Watt worked tirelessly on a series of other improvements to practically every part of the engine. Watt further improved the system by adding a small vacuum pump to pull the steam out of the cylinder into the condenser, further improving cycle times.

The Further various developments on the Newcomen engine continued and these led to what was known as the Cornish engine designed by James Watt. It can be thought of as the improved version of Watt's Steam Condenser engine.

This more radical change from the Newcomen design was closing off the top of the cylinder and introducing low-pressure steam above the piston.

Now the power was not due to the difference of atmospheric pressure and the vacuum, but the pressure of the steam and the vacuum, that was of somewhat higher value.

On the upward return stroke, the steam on top was transferred through a pipe to the underside of the piston ready to be condensed for the downward stroke. Sealing of the piston on a Newcomen engine had been achieved by maintaining a small quantity of water on its upper side. This was no longer possible in Watt's engine due to the presence of the steam.

Watt spent considerable effort to find a seal that worked, eventually obtained by using a mixture of tallow and oil. The piston rod also passed through a gland on the top cylinder cover, sealed in a similar way.

In a Watt Steam Condenser engine, steam is admitted throughout the piston's power stroke. At the end of the stroke, the steam is exhausted, and any remaining energy is wasted in the condenser, where the steam is cooled back to water.

In a Cornish engine, by contrast, the intake valve is shut off midway through the power stroke, allowing the steam already in that part of the cylinder to expand through the rest of the stroke to a lower pressure. This results in the capture of a greater proportion of its energy, and less heat being lost to the condenser, than in a Watt engine.

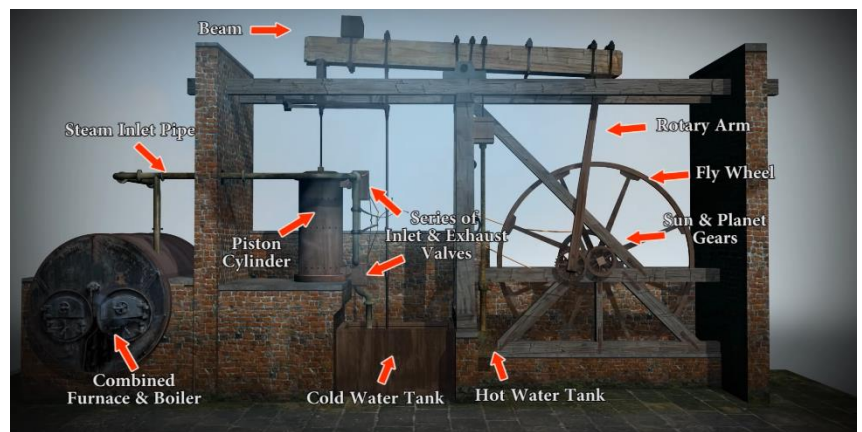

*Watt's Cornish Engine*

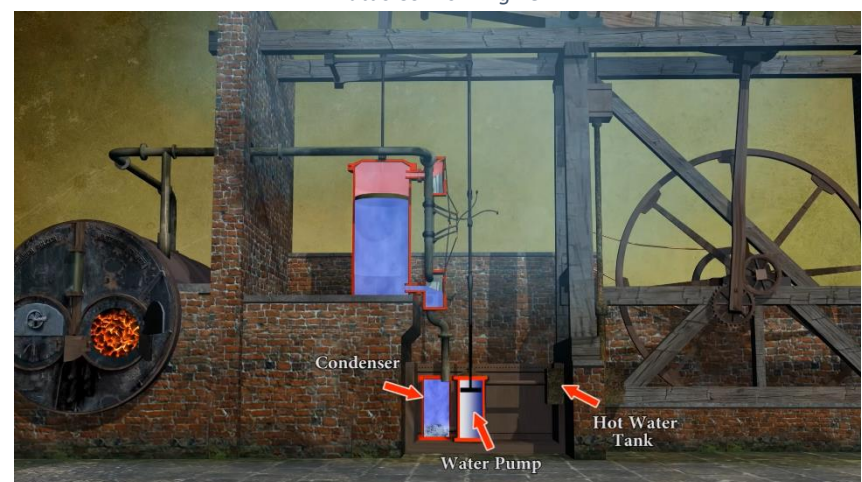

*Top Valve open on the end of the up-stroke*



*Bottom - Equilibrium valve open at end of the down-stroke*



The Cornish cycle operates as follows:  
Starting from a condition during operation with the piston at the top of the cylinder, the cylinder below the piston full of steam from the previous stroke, the boiler at normal working pressure, and the condenser at normal working vacuum.

1. The pressurized steam inlet valve and low-pressure steam exhaust valves are opened. Pressurized steam from the boiler enters the top part of the cylinder above the piston, pushing it down, and the steam below the piston is drawn into the condenser, creating a vacuum below the piston. The pressure difference between the steam at boiler pressure above the piston and the vacuum below it drives the piston down.

2. Part way down the stroke, the pressurized steam inlet valve is closed. The steam above the piston then expands through the rest of the stroke, while the low-pressure steam on the other side (bottom) of the piston continues to be drawn into the condenser, thereby maintaining the partial vacuum in that part of the cylinder.

3. At the bottom of the stroke, the exhaust valve to the condenser is closed and the equilibrium valve is opened. The weight of the pump gear draws the piston up, and as the piston comes up, steam is transferred through the equilibrium pipe from above the piston to the bottom of the cylinder below the piston.

4. When the piston reaches the top of the cylinder, the cycle is ready to repeat.

Watt finally considered the design good enough to release in 1774 and the Watt engine was released to the market. As portions of the design could be easily fitted into existing Newcomen engines, there was no need to build an entirely new engine at the mines. Instead, Watt and his business partner Matthew Boulton licensed the improvements to engine operators, charging them a portion of the money they would save in reduced fuel costs. The design was wildly successful, and the Boulton and Watt company was formed to license the design and help new manufacturers build the engines. The two would later open the Soho Foundry to produce engines of their own. James Watt had witnessed the hardships while treading the path to success, his life and work have served as the milestone for future generations.

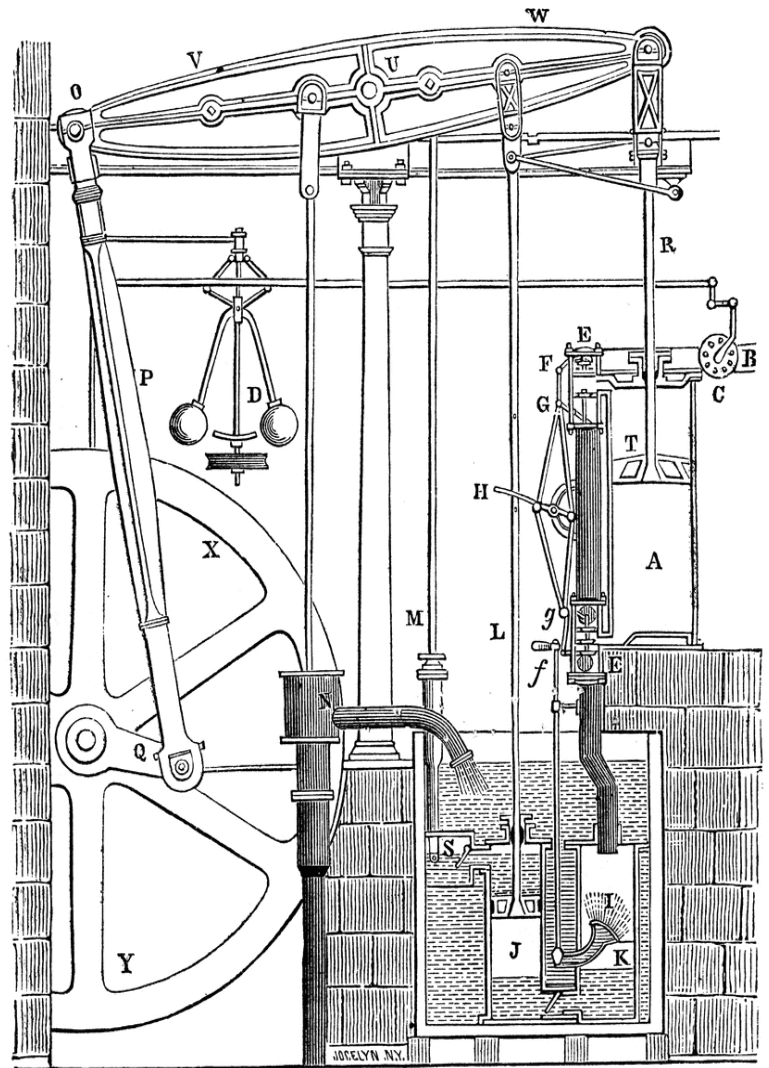

*A more detailed look at Watt's Cornish Engine*

---

### 3.8 - Converting reciprocating motion to Rotary motion

The success of the watt engine in the mining industry led to the idea that such an engine could be used in other industries. Therefore, the idea was adopted and in 1781 a single acting rotative beam engine was developed and in 1783 a double acting beam engine as an improvement of the same proto-type was developed. The crank arrangement was developed as an improvement to change the reciprocating motion of the piston to that of rotation for the crank and shaft 'crankshaft'.

Boulton & Watt developed the reciprocating engine into the rotative type. Unlike the Newcomen engine, the Watt engine could operate smoothly enough to be connected to a drive shaft via sun and planet gears.

The sun and planet gear converted the vertical motion of a beam, driven by a steam engine, into circular motion using a 'planet', a cogwheel fixed at the end of the connecting rod (connected to the beam) of the engine.

With the motion of the beam, this revolved around, and turned, the 'sun', a second rotating cog fixed to the drive shaft, thus generating rotary motion.

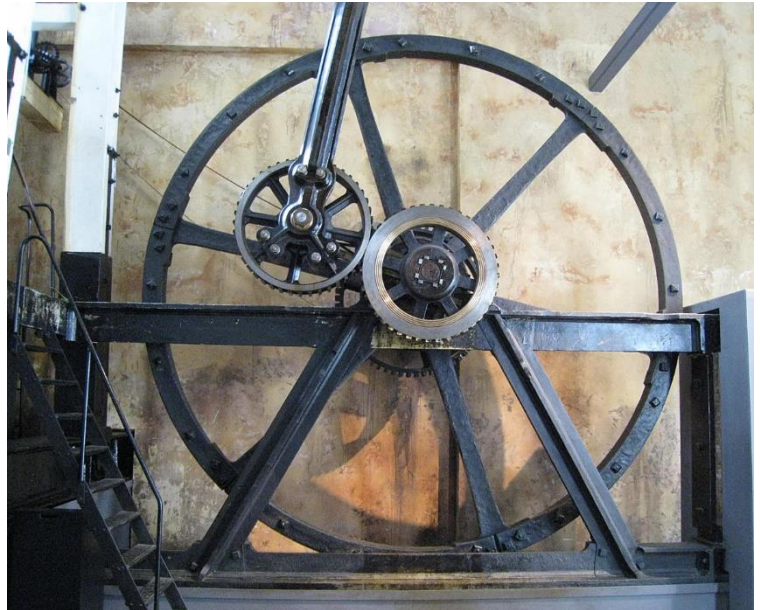

*The Well-Known Sun and Planet Gear patented by James Watt*

An interesting feature of this arrangement, when compared to that of a simple crank, is that when both sun and planet have the same number of teeth, the drive shaft completes two revolutions for each double stroke of the beam instead of one. The planet gear is fixed to the connecting rod and thus does not rotate around its own axis.

Note that the axle of the planet gear is tied to the axle of the sun gear by a link that freely rotates around the axis of the sun gear and keeps the planet gear engaged with the sun gear but does not contribute to the drive torque. This link appears, at first sight, to be similar to a crank but the drive is not transmitted through it. Thus, it did not contravene the crank patent.

It was invented by the Scottish engineer William Murdoch, an employee of Boulton and Watt, but was patented by James Watt in October 1781. The purpose was to bypass the patent on the crank, already held by James Pickard. It played an important part in the development of devices for rotation in the Industrial Revolution.

James Pickard was an English inventor. He modified the Newcomen engine in a manner that it could deliver a rotary motion. His solution, which he patented in 1780, involved the combined use of a crank and a flywheel.

A crank is an arm attached at a right angle to a rotating shaft by which circular motion is imparted to or received from the shaft. When combined with a connecting rod, it can be used to convert circular motion into reciprocating motion, or vice versa. The arm may be a bent portion of the shaft, or a separate arm or disk attached to it. Attached to the end of the crank by a pivot is a rod, usually called a connecting rod (conrod).

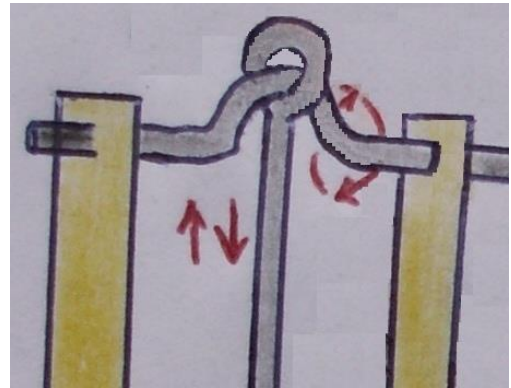

Compound Crank example

### 3.9 – Watt’s Flyball Governor

The drive shaft of Watt's speed sensor is geared to the steam engine's main drive shaft and rotates at a convenient speed in unison with it. As it rotates the two heavy balls are driven outwards by the centrifugal force.

As the weights fly outwards, a sliding ring on the drive shaft is pulled downwards by the scissor mechanism supporting the weights. This displacement of the ring along the shaft represents the magnitude and direction of the speed error.

A linkage mechanism provides the feedback loop which transfers this movement to the butterfly valve of the throttle control. The pivot in the linkage reverses the direction of the error signal thus, providing the negative feedback.

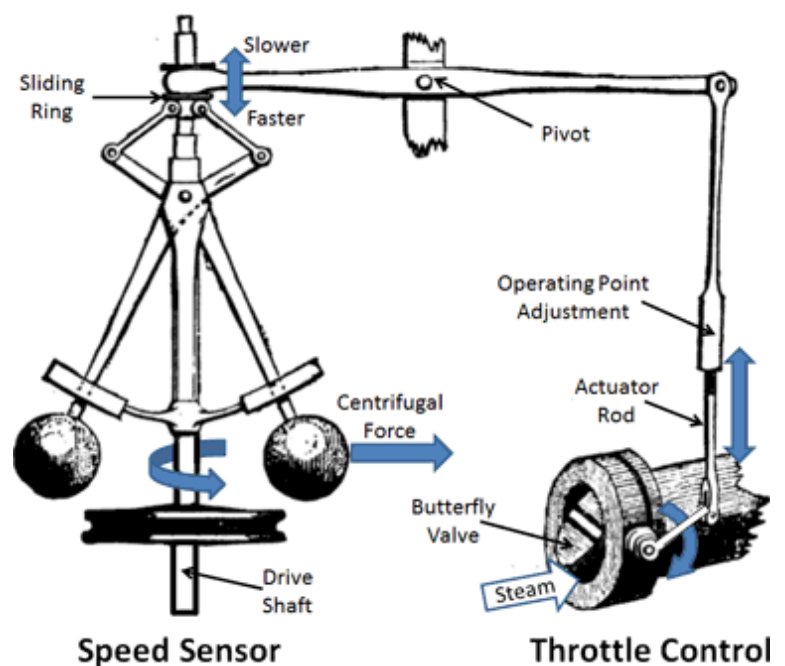

Flyball governor which was used on Watt's Steam engines

If the engine speed is too high, the centrifugal force on the sensor's weights will cause the actuator rod to be raised, in turn causing the butterfly valve to move so as to restrict the flow of steam into the engine, hence reducing its speed.

Conversely, if the engine speed is too low, the centrifugal force will be lower and the weights will be closer to the drive shaft and the sliding ring will ride higher on the drive shaft. This will force the actuator rod downwards opening up the butterfly valve to admit more steam into the engine thus increasing its speed.

The desired speed of the engine is set by means of a screw thread on the actuator rod which adjusts the rod's length thus enabling the angle of the butterfly valve to be set to the corresponding operating point.

### 3.10 – Watt’s Pressure Gauge

In 1790 James Watt completed the "Watt engine" by inventing the pressure gauge to monitor steam pressure which revolutionized the industries in that era. This was the first device intended to measure the varying pressures within a steam engine’s cylinder as it was working. The manometer liquids most commonly used are mercury, oil, alcohol and water.

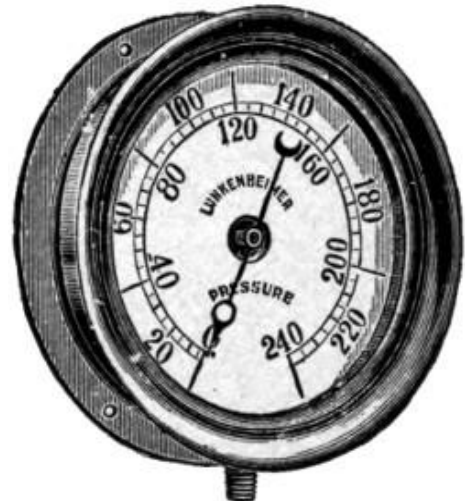

Watt's Pressure Gauge

### 3.11 – Watt’s Parallel Motion

The parallel motion is a mechanical linkage invented by the Scottish engineer James Watt in 1784 for the double-acting Watt steam engine. It allows a rod moving straight up and down to transmit motion to a beam moving in an arc, without putting sideways strain on the rod.

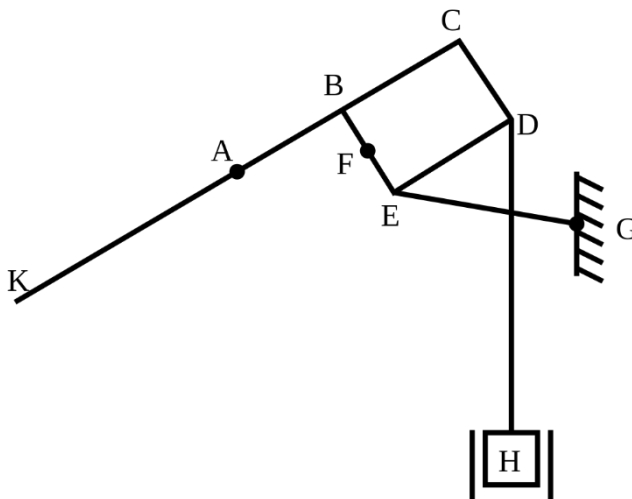

Watt's Parallel Motion Diagram



Watt's Parallel Motion in a Steam Engine

### 3.12 – Watt’s Legacy

The Watt engine was a defining development of the Industrial Revolution because of its rapid incorporation into many industries including the marine sector. Because of Watt’s contributions to science and industry, the watt, the unit of power in the International System of Units (SI) equal to one joule of work performed per second, was named after him.

Some scientists argue that the design of the parallel motion (or double-acting engine) in 1784 should serve as the starting point of the Anthropocene Epoch—the unofficial interval of geologic time in which human activity began to substantially alter Earth’s surface, atmosphere, and oceans.

---

### 3.13 – High – Pressure Engines

As the 18th century advanced, there was a call for higher pressures; this was strongly resisted by Watt who used the monopoly his patent gave him to prevent others from building high-pressure engines and using them in vehicles. He mistrusted the boiler technology of the day, the way they were constructed and the strength of the materials used.

#### The important advantages of high-pressure engines were:

1. They could be made much smaller than previously for a given power output. There was thus the potential for steam engines to be developed that were small and powerful enough to propel themselves and other objects. As a result, steam power for transportation now became a practicality in the form of ships and land vehicles, which revolutionised cargo businesses, travel, military strategy, and essentially every aspect of society.
2. Because of their smaller size, they were much less expensive.
3. They did not require the significant quantities of condenser cooling water needed by atmospheric engines.
4. They could be designed to run at higher speeds, making them more suitable for powering machinery.

#### The disadvantages were:

1. In the low-pressure range they were less efficient than condensing engines, especially if steam was not used expansively.
2. They were more susceptible to boiler explosions.

The main difference between how high-pressure and low-pressure steam engines work is the source of the force that moves the piston. In the engines of Newcomen and Watt, it is the condensation of the steam that creates most of the pressure difference, causing atmospheric pressure (Newcomen) and low-pressure steam, seldom more than 7 psi boiler pressure, plus condenser vacuum (Watt), to move the piston.

In a high-pressure engine, most of the pressure difference is provided by the high-pressure steam from the boiler; the low-pressure side of the piston may be at atmospheric pressure or connected to the condenser pressure.

Late eighteenth-century precision boring mills finally made tight-fitting high-pressure pistons possible. Inventor Richard Trevithick and American millwright Oliver Evans both made high-pressure engines just after 1800. So, it finally made sense to fit a steam engine into a vehicle. Instead of condensing steam to create a vacuum, builders simply blew spent steam into the atmosphere.

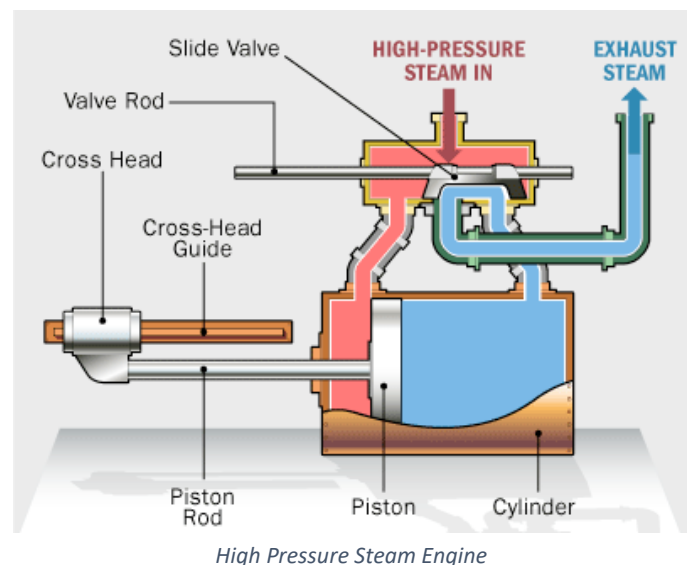

---

The importance of raising steam under pressure (from a thermodynamic standpoint) is that it attains a higher temperature. Thus, any engine using high-pressure steam operates at a higher temperature and pressure differential than what is possible with a low-pressure vacuum engine. The high-pressure engine thus became the basis for most further developments of reciprocating steam technology.

Even so, around the year 1800, "high pressure" amounted to what today would be considered very low pressure i.e., 40-50 psi (276-345 kPa), the point being that the high-pressure engine in question was non-condensing, driven solely by the expansive power of the steam, and once that steam had performed work it was usually exhausted at higher-than-atmospheric pressure.

The blast of the exhausting steam into the chimney could be exploited to increase the rate of burning, hence creating more heat in a smaller furnace, at the expense of creating back pressure on the exhaust side of the piston.

The first high-pressure steam engine was invented in 1800 by Richard Trevithick. He was not the first to think of the so-called "strong steam" or steam of about 30 psi (210 kPa). William Murdoch had developed and demonstrated a model steam carriage, initially in 1784, and demonstrated it to Trevithick at his request in 1794. In fact, Trevithick lived next door to Murdoch in Redruth in 1797 and 1798. Not only would a high-pressure steam engine eliminate the condenser, but it would allow the use of a smaller cylinder, saving space and weight.

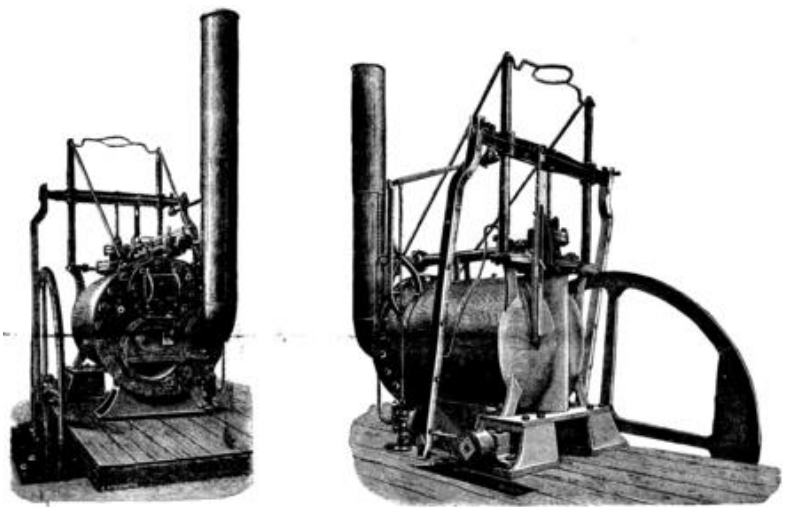

*Trevithick's High-Pressure Steam Engine*

Oliver Evans was also in favour of "strong steam" which he applied to boat engines and to stationary uses. He was a pioneer of cylindrical boilers; however, Evans' boilers did suffer several serious boiler explosions, which tended to lend weight to Watt's qualms. He founded the Pittsburgh Steam Engine Company in 1811 in Pittsburgh, Pennsylvania. The company introduced high-pressure steam engines to the riverboat trade in the Mississippi watershed.

---

### 3.14 – Compound Steam Engines

Compounding involves two or more cylinders; low-pressure steam from the first, high-pressure, cylinder is passed to the second cylinder where it expands further and provides more drive. This is the compound effect; the waste steam from this can produce further work if it is then passed into a condenser in the normal way.

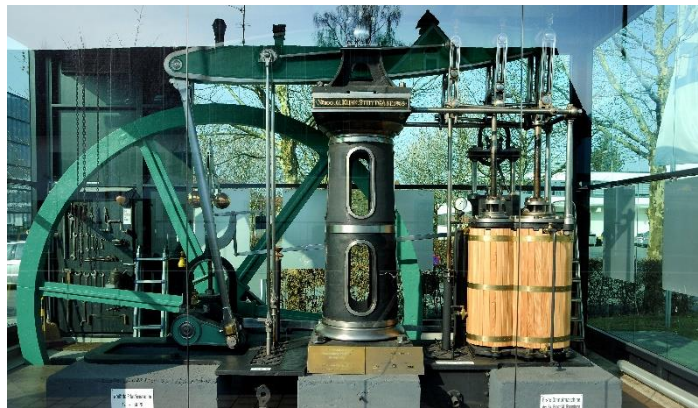

*Woolf's Compound-Double Expansion Steam Engine*

The first experiment with compounding was conducted by Jonathan Hornblower, who took out a patent in 1781. His first engine was installed at Tincroft Mine, Cornwall. It had two cylinders – one 21-inch (0.53 m) diameter with 6-foot (1.8 m) stroke and one 27-inch (0.69 m) diameter with 8-foot (2.4 m) stroke – placed alongside each other at one end of the beam.

The early engines showed little performance gain: the steam pressure was too low, interconnecting pipes were of small diameter and the condenser ineffective. Even though this was a revolutionary new steam technology, Jonathan was unfortunately prevented from pursuing his invention by litigation with James Watt (Boulton & Watt) over intellectual property.

His compound engine principle was not revived until 1804 (by Arthur Woolf) following the expiration of Boulton and Watt's patent. Hornblower's compound engine principle contributed significantly to the increases in steam engine efficiency and it was the foundation of the expansion engine.

A method to lessen the magnitude of the continual heating and cooling of a single-expansion steam engine that leads to inefficiency was invented by British engineer Arthur Woolf.

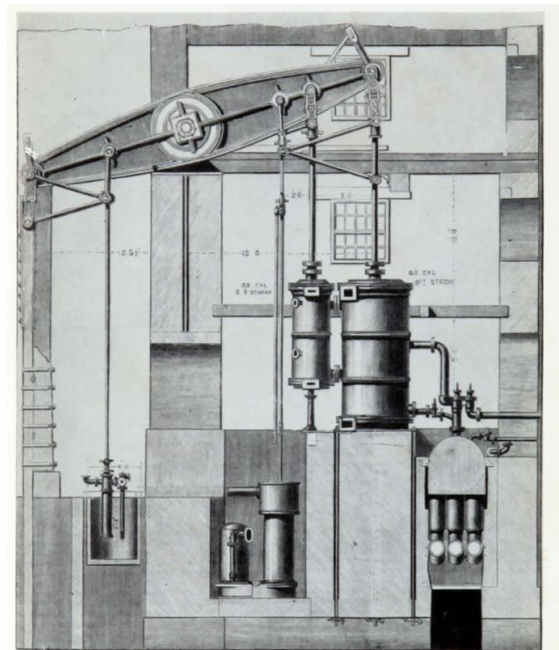

*Woolf's Compound Steam Engine*

Woolf patented his stationary Woolf high-pressure compound engine in 1805. Successful Woolf compound engines were produced in 1814, for the Wheal Abraham copper mine and the Wheal Vor tin mine. Compound steam engines are otherwise known as double expansion steam engines.

### 3.15 – Corliss Steam Engine

A Corliss steam engine (or Corliss engine) is a steam engine, fitted with rotary valves and with variable valve timing, patented in 1849, invented by and named after the American engineer George Henry Corliss of Providence, Rhode Island.

It was called the greatest improvement since James Watt. The Corliss engine had greatly improved speed control and better efficiency, making it suitable to all sorts of industrial applications, including spinning.

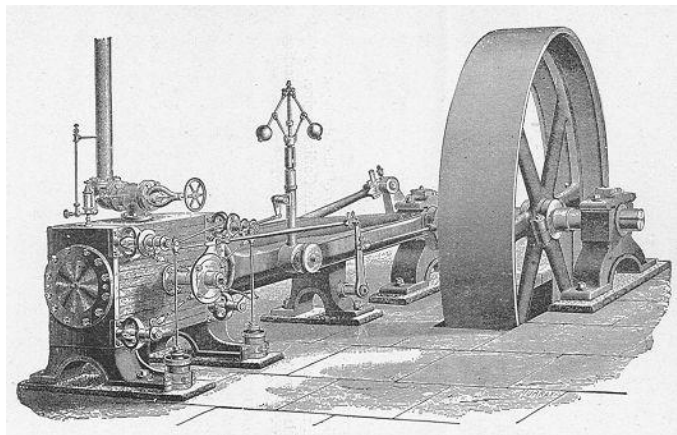

The Corliss Steam Engine

#### Corliss Valve Gear Operation:

The sequence begins with the piston at one end of the cylinder. At this point, the exhaust valve in the left end of the cylinder is opened and the steam inlet valve in the right end of the cylinder is opened (figure 1). When the steam enters the cylinder, it pushes the piston toward the left end of the cylinder. Part way through the stroke the right inlet valve is closed and the steam in the cylinder continues to expand and push the piston (figure 2). When the far end of the stroke is reached, the valve gear rotates the exhaust valve in the right end of the cylinder open as the inlet valve in the left end of the cylinder is opened (figure 3). This allows the steam to the right of the piston to escape the cylinder as live steam now pushes on the left side of the piston (figure 4). Part way through the return stroke the inlet valve closes and the expansion of the steam pushes the piston to the end of its travel. At this point the cycle begins again.

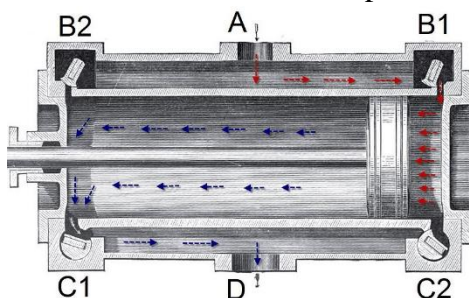
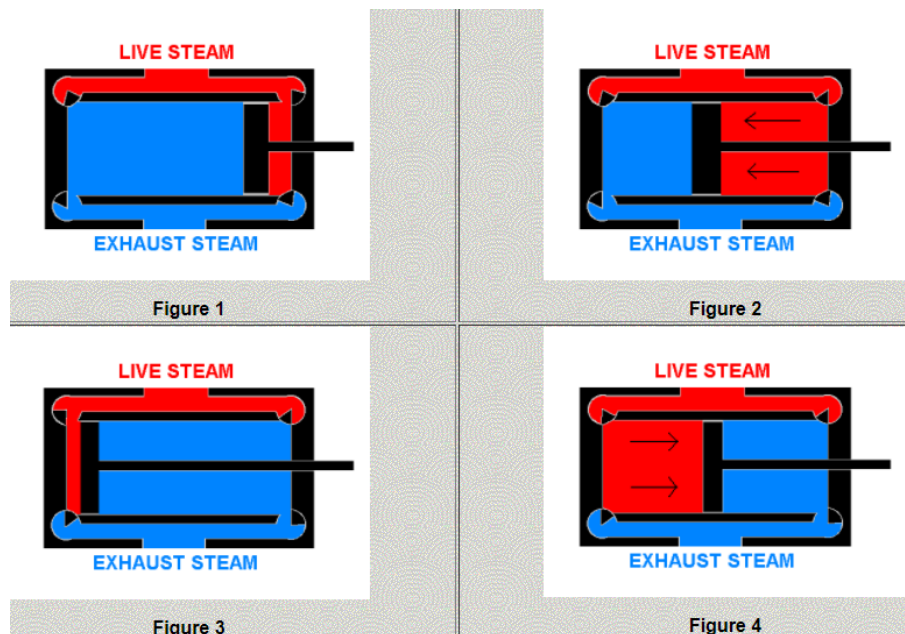

THE CORLISS ENGINE CYLINDER.

Engines fitted with Corliss valve gear offered the best thermal efficiency of any type of stationary steam engine until the refinement of the uniflow steam engine and steam turbine in the 20th century. Corliss engines were generally about 30 percent more fuel efficient than conventional steam engines with fixed cutoff.



---

### 3.16 – Multiple Expansion Steam Engine

In 1861, Daniel Adamson took out a patent for a multiple-expansion engine, with three or more cylinders connected to one beam or crankshaft. He built a triple-expansion engine for Victoria Mills, Dukinfield which opened in 1867.

It is a logical extension of the compound engine-double expansion engine, to split the expansion into yet more stages to increase efficiency. The result is the multiple-expansion engine. Such engines use either three or four expansion stages and are known as triple- and quadruple-expansion engines respectively.

These engines use a series of double-acting cylinders of progressively increasing diameter and/or stroke and hence volume. These cylinders are designed to divide the work into three or four equal portions, one for each expansion stage. The steam travels through the engine from left to right. The valve chest for each of the cylinders is to the left of the corresponding cylinder.

The development of this type of engine was important for its use in steamships as by exhausting to a condenser the water could be reclaimed to feed the boiler, which was unable to use seawater. Land-based steam engines could simply exhaust much of their steam, as feed water was usually readily available.

Prior to and during World War II, the expansion engine dominated marine applications where high vessel speed was not essential.

It was superseded by the steam turbine when speed was required, such as for warships and ocean liners.

In 1872, Sir Fredrick J. Bramwell reported that compound marine engines, operating at 45psi to 60psi, consumed 2 lbs to 2.5 lbs of coal per hour per indicated horsepower. Lasty in 1881, Alexander C. Kirk designs the first practical triple expansion engine which was later installed in SS Aberdeen.

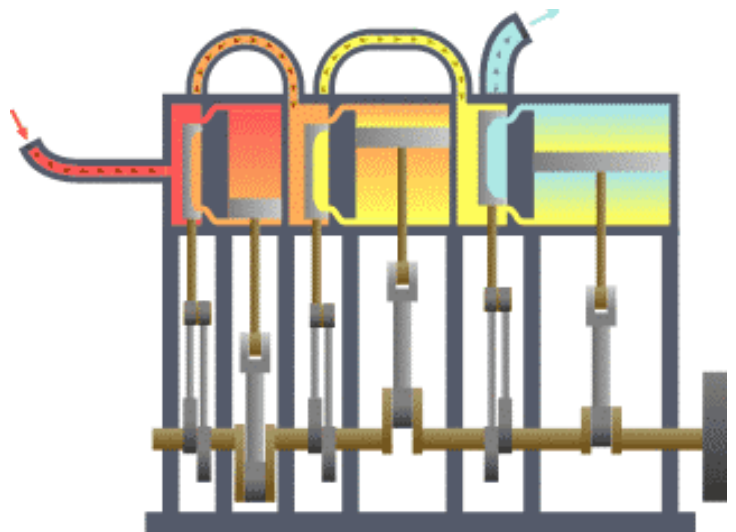

*Triple Expansion Steam Engine with HP - IP - LP*



*Triple Expansion Steam Engine*

### 3.17 – High Speed Steam Engine

The Porter-Allen engine, introduced in 1862, used an advanced valve gear mechanism developed for Porter by Allen, a mechanic of exceptional ability, and was at first generally known as the Allen engine. The high-speed engine was a precision machine that was well balanced. It was made possible by advancements in machine tools and manufacturing technology. It ran at piston speeds from three to five times the speed of ordinary engines. It also had low speed variability.

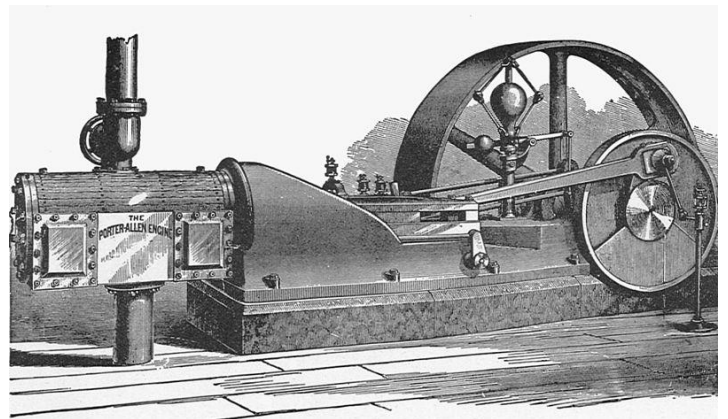

*Port-Allen High Speed Steam Engine*

The engine had several advantages. It could be directly coupled. If gears or belts and drums were used, they could be much smaller sizes. The engine itself was also small for the amount of power it developed. Porter greatly improved the fly-ball governor by reducing the rotating weight and adding a weight around the shaft. This significantly improved speed control. Porter's governor became the leading type by 1880. The efficiency of the Porter-Allen engine was good, but not equal to the Corliss engine.

### 3.18 – The Steam Turbine

The first device that may be classified as a reaction steam turbine was little more than a toy, the classic Aeolipile, described in the 1st century by Hero of Alexandria in Roman Egypt. Steam turbines were also described by the Italian Giovanni Branca (1629) and John Wilkins in England (1648).

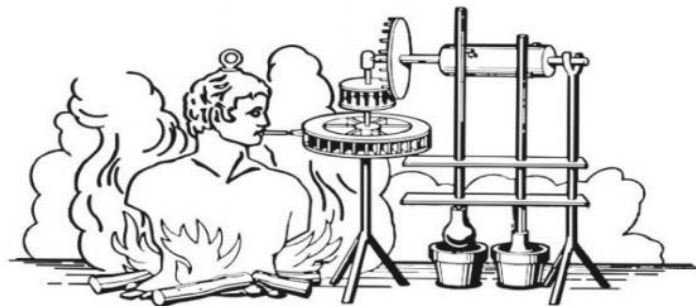

*Govanni de Branca's Turbine*

A steam turbine is basically a device that extracts thermal energy from pressurized steam and uses it to do mechanical work on a rotating output shaft. Its modern manifestation was invented by Charles Parsons in 1884.

It is a form of heat engine that derives much of its improvement in thermodynamic efficiency from the use of multiple stages in the expansion of the steam, which results in a closer approach to the ideal reversible expansion process. Because the turbine generates rotary motion, it is particularly suited to be used to drive an electrical generator—about 85% of all electricity generation in the United States in the year 2014 was by use of steam turbines.

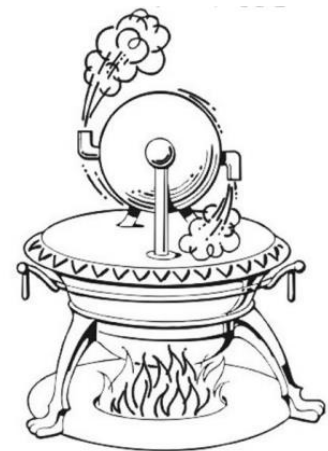

*Hero of Alexandria's turbine*

## Turbine Blades

Turbine blades are of two basic types, blades and nozzles. Blades move entirely due to the impact of steam on them and their profiles do not converge. This results in a steam velocity drop and essentially no pressure drop as steam moves through the blades. A turbine composed of blades alternating with fixed nozzles is called an impulse turbine. Nozzles appear similar to blades, but their profiles converge near the exit. This results in a steam

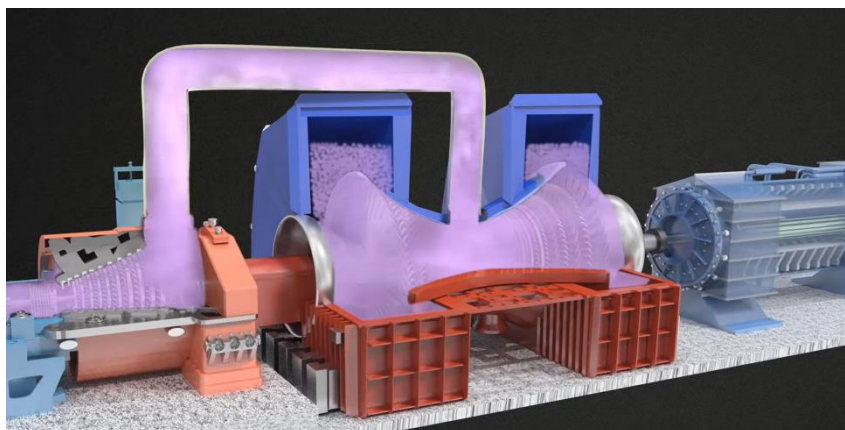

Modern Reaction Steam Turbine

pressure drop and velocity increase as steam moves through the nozzles. Nozzles move due to both the impact of steam on them and the reaction due to the high-velocity steam at the exit. A turbine composed of moving nozzles alternating with fixed nozzles is called a *reaction turbine*.

## Impulse Turbines

An impulse turbine has fixed nozzles that orient the steam flow into high-speed jets. These jets contain significant kinetic energy, which is converted into shaft rotation by the bucket-like shaped rotor blades, as the steam jet changes direction.

A pressure drop occurs across only the stationary blades, with a net increase in steam velocity across the stage. As the steam flows through the nozzle its pressure falls from inlet pressure to the exit pressure (atmospheric pressure or, more usually, the condenser vacuum).

Due to this high ratio of expansion of steam, the steam leaves the nozzle with very high velocity.

The steam leaving the moving blades has a large portion of the maximum velocity of the steam when leaving the nozzle. The loss of energy due to this higher exit velocity is commonly called the *carry over velocity* or *leaving loss*.

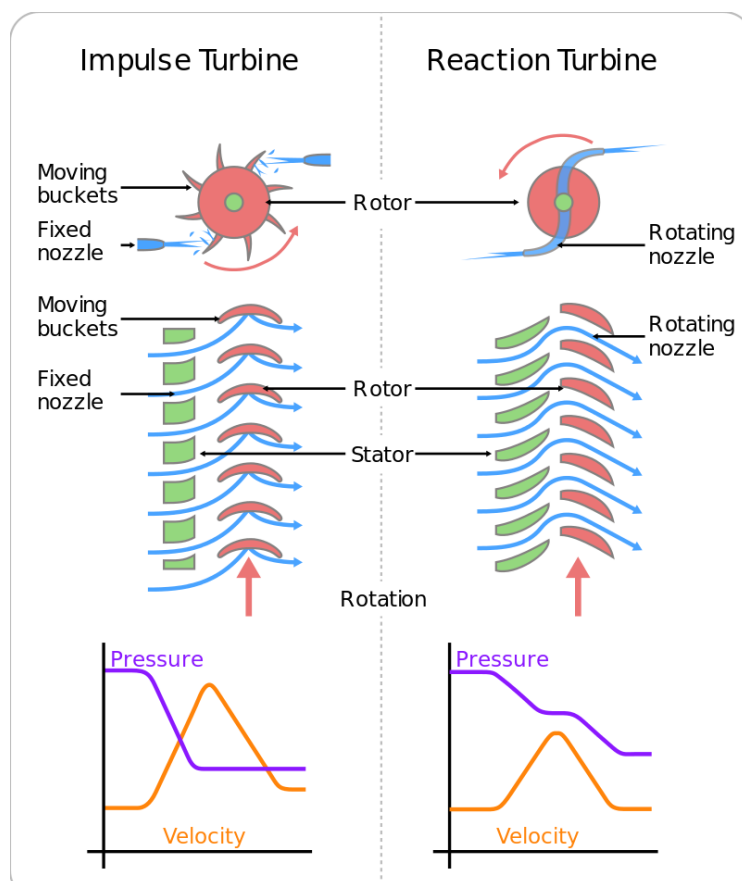

Impulse and Reaction Turbine Diagram

## Reaction Turbines

In the reaction turbine, the rotor blades are arranged to form convergent nozzles.

This type of turbine makes use of the reaction force produced as the steam accelerates through the nozzles formed by the rotor.

Steam is directed onto the rotor by the fixed vanes of the stator. It leaves the stator as a jet that fills the entire circumference of the rotor. The steam then changes direction and increases its speed relative to the speed of the blades.

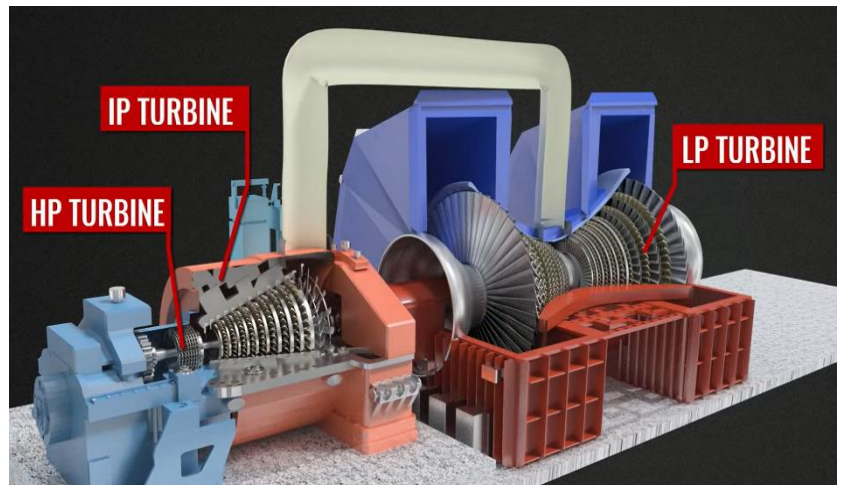

Reaction turbine with 3 different pressure chambers

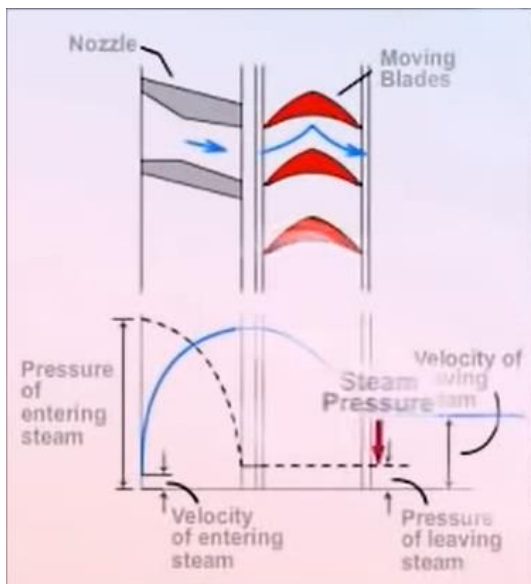

Impulse Turbine

In steamships, advantages of steam turbines over reciprocating engines are smaller size, lower maintenance, lighter weight, and lower vibration.

A steam turbine is efficient only when operating in the thousands of RPM, while the most effective propeller designs are for speeds less than 300 RPM; consequently, precise (thus expensive) reduction gears are usually required.

In general, reaction turbines are more efficient as compared to impulse turbines.

A pressure drop occurs across both the stator and the rotor with steam accelerating through the stator and decelerating through the rotor, with no net change in steam velocity across the stage, but with a decrease in both pressure and temperature, reflecting the work performed in the driving of the rotor.

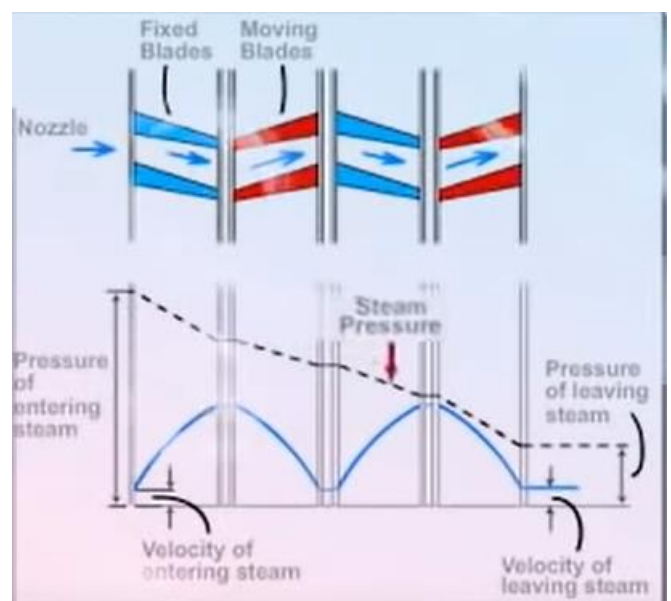

Reaction Turbine

The higher cost of turbines and the associated gears or generator/motor sets is offset by lower maintenance requirements and the smaller size of a turbine in comparison with a reciprocating engine of equal power. Furthermore, the fuel costs are higher than those of a diesel engine because steam turbines have lower thermal efficiency. In order to reduce fuel costs, the thermal efficiency of both types of engines have been improved over the years.

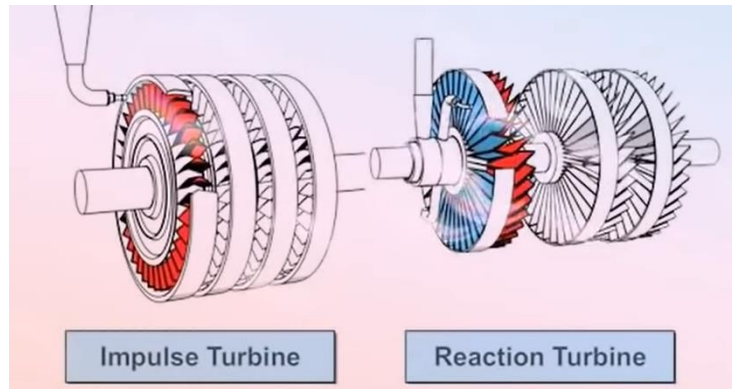

*Side comparison of Impulse and Reaction Turbine*

## **Turbo-Electric Transmission**

Turbo-electric transmission uses electric generators to convert the mechanical energy of a turbine (steam or gas) into electric energy and electric motors to convert it back into mechanical energy to power the driveshafts.

A steam turbine ship can have either direct propulsion (the turbines, equipped with a reduction gear, rotate directly the propellers), or turboelectric (the turbines rotate electric generators, which in turn feed electric motors operating the propellers). An advantage of turbo-electric transmission is that it allows the adaptation of high-speed turbines to slow turning propellers or wheels without a heavy and complex gearbox.

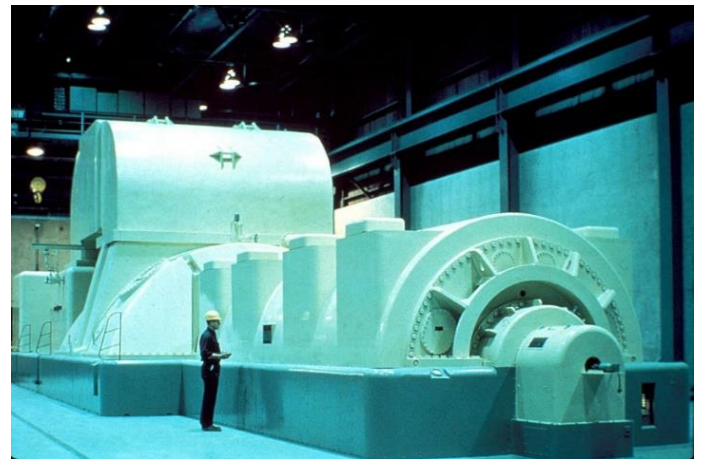

*Modern Steam Turbine Generator*

It has the advantage of being able to provide electricity for the ship's other electrical systems, such as lighting, computers, radar and communications equipment.

### 3.19 – The Uniflow Steam Engine

The uniflow engine was first used in Britain in 1827 by Jacob Perkins and was patented in 1885 by Leonard Jennett Todd. It was popularized by German engineer Johann Stumpf in 1909, with the first commercial stationary engine produced a year previously in 1908.

The uniflow type of steam engine uses steam that flows in one direction only in each half of the cylinder. Thermal efficiency is increased by having a temperature gradient along the cylinder. Steam always enters at the hot ends of the cylinder and exhausts through ports at the cooler center. By this means, the relative heating and cooling of the cylinder walls is reduced.

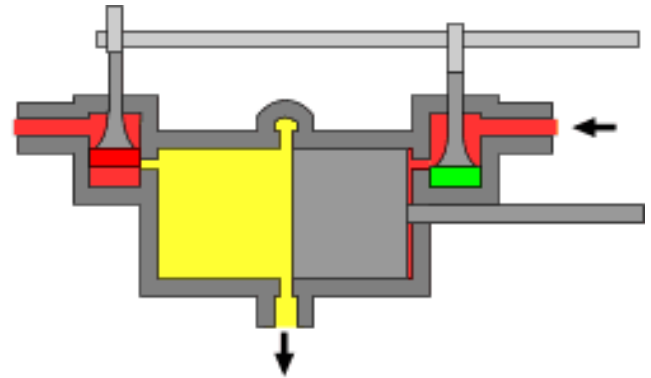

*Uniflow Steam Engine Cylinder*

One of the disadvantages is that because there is a thermal gradient across the cylinder, the metal of the wall expands to different extents. This requires the cylinder bore to be machined wider in the cool center than at the hot ends. If the cylinder is not heated correctly, or if water enters, the delicate balance can be upset causing disruption mid-stroke or potentially, destruction.

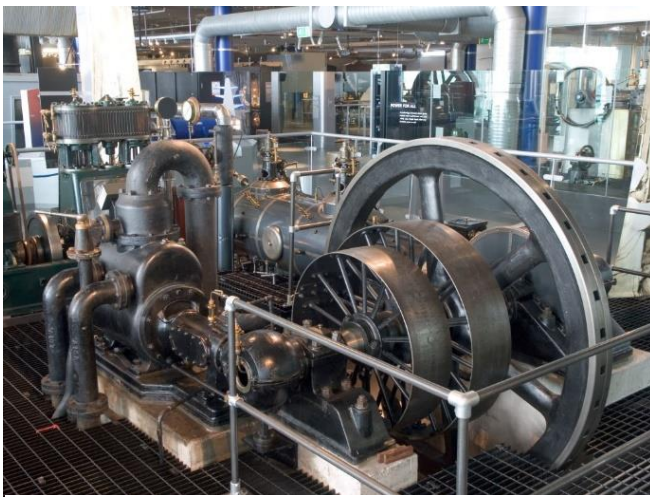

*Birmingham Science Museum*

Further development of the steam engine during the 20th century was arrested or severely limited by the development of the internal combustion engine for mobile applications, and the steam turbine for large scale electric power generation. The reciprocating steam engine nonetheless continued to play a very important role through the end of WWII, powering a majority of freighters and troop transport ships, as well as the majority of locomotives. An obvious advantage of the steam engine over the internal combustion engine is its ability to burn low-cost solid fuels, including coal and biomass.

The uniflow engine was the most efficient type of high-pressure steam engine. It was used in ships, but was displaced by steam turbines and later marine diesel engines.

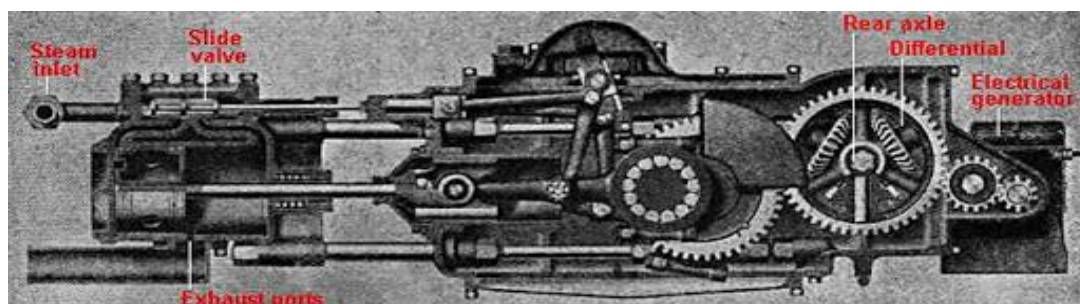

*Uniflow Steam Engine*

---

## CHAPTER 4 – STEAM ENGINES CLASSIFIED BY CONNECTION MECHANISM

### 4.1 – Side Lever

In the early years of steam navigation, the side-lever was the most common type of marine engine for inland waterway and coastal service in Europe, and it remained for many years the preferred engine for oceangoing service on both sides of the Atlantic.

The side-lever was an adaptation of the earliest form of a steam engine, the beam engine. The typical side-lever engine had a pair of heavy horizontal iron beams, known as side levers, that connected in the center to the bottom of the engine with a pin. This connection allowed a limited arc for the levers to pivot in. A piston rod, connected vertically to the piston, extended out of the top of the cylinder. This rod attached to a horizontal crosshead, connected at each end to vertical rods (known as side-rods). These rods connected down to the levers on each side of the cylinder. This formed the connection of the levers to the piston on the cylinder side of the engine.

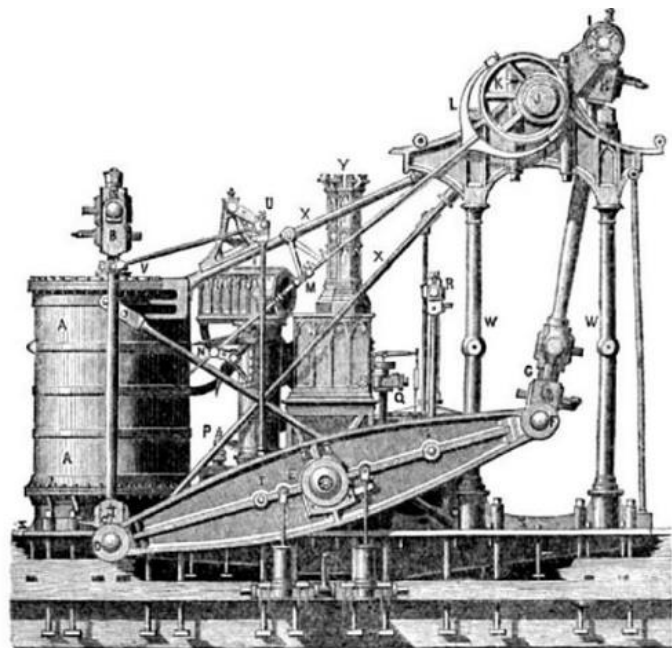

*The Side Lever Engine*

The other side of the levers (the opposite end of the lever pivot to the cylinder) was connected to each other with a horizontal cross tail. This cross tail in turn connected to and operated a single connecting rod, which turned the crankshaft. The rotation of the crankshaft was driven by the levers—which, at the cylinder's side, were driven by the piston's vertical oscillation.

The main disadvantage of the side-lever engine was that it was large and heavy. For inland waterway and coastal service, lighter and more efficient designs soon replaced it. It remained the dominant engine type for oceangoing service through much of the first half of the 19th century, due to its relatively low center of gravity, which gave ships more stability in heavy seas. It was also a common early engine type for warships, since its relatively low height made it less susceptible to battle damage.

The side-lever engine was a paddlewheel engine and was not suitable for driving screw propellers. The last ship built for transatlantic service that had a side-lever engine was the Cunard Line's paddle steamer RMS Scotia, considered an anachronism when it entered service in 1862.

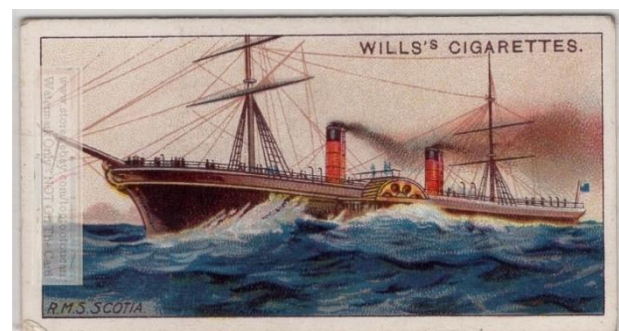

*RMS Scotia*

---

## 4.2 - Grasshopper

The grasshopper or 'half-lever' engine was a variant of the side-lever engine. The grasshopper engine differs from the conventional side-lever in that the location of the lever pivot and connecting rod are more or less reversed, with the pivot located at one end of the lever instead of the center, while the connecting rod is attached to the lever between the cylinder at one end and the pivot at the other.

Chief advantages of the grasshopper engine were cheapness of construction and robustness, with this type said to require less maintenance than any other type of marine steam engine. Another advantage is that the engine could be easily started from any crank position. Like the conventional side-lever engine however, grasshopper engines were disadvantaged by their weight and size. They were mainly used in small watercrafts such as riverboats and tugs.

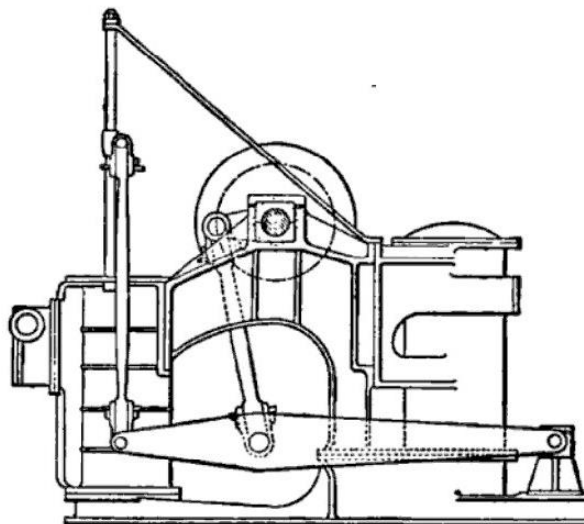

*The Grasshopper Engine*

## 4.3 – Crosshead (square)

The crosshead engine, also known as a square, sawmill or A-frame engine, was a type of paddlewheel engine used in the United States. It was the most common type of engine in the early years of American steam navigation.

The crosshead engine is described as having a vertical cylinder above the crankshaft, with the piston rod secured to a horizontal crosshead, from each end of which, on opposite sides of the cylinder, extended a connecting rod that rotated its own separate crankshaft. The crosshead moved within vertical guides so that the assembly maintained the correct path as it moved.

The engine's alternative name—"A-frame"—presumably derived from the shape of the frames that supported these guides.

Because the cylinder was above the crankshaft in this type of engine, it had a high center of gravity, and was therefore deemed unsuitable for oceangoing service. This largely confined it to vessels built for inland waterways. As marine engines grew steadily larger and heavier through the 19th century, the high center of gravity of square crosshead engines became increasingly impractical, and by the 1840s, ship builders abandoned them in favor of the walking beam engine.

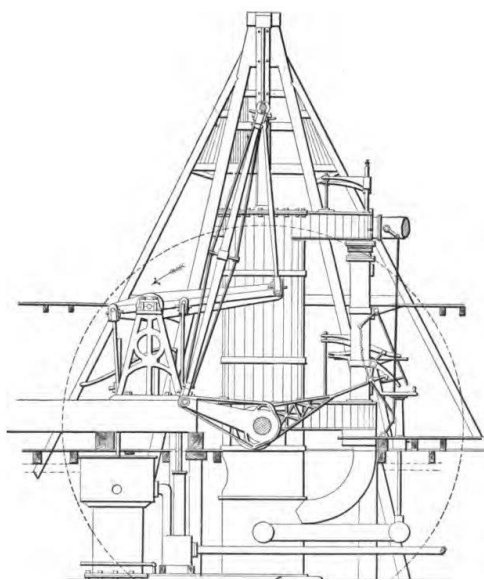

*Diagram of a typical Hudson River Steamboat Crosshead Engine (Side view)*



The name of this engine can cause confusion, as "crosshead" is also an alternative name for the steeple engine (below). Many sources thus prefer to refer to it by its informal name of "square" engine to avoid confusion. Additionally, the marine crosshead or square engine described in this section should not be confused with the term "square engine" as applied to internal combustion engines, which in the latter case refers to an engine whose bore is equal to its stroke.

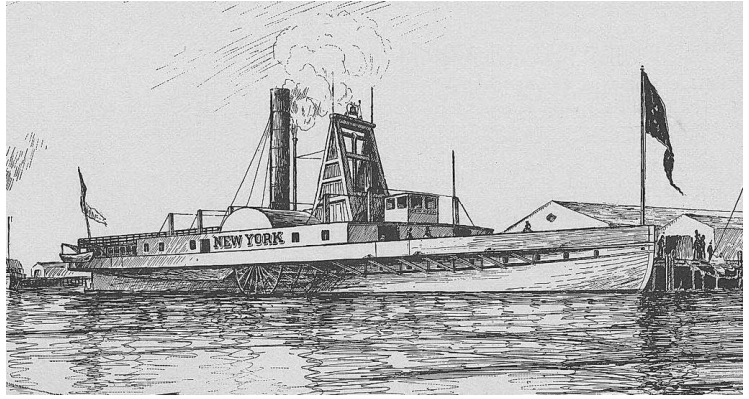

*A-Frame Engine fitted on the 1836 Paddle Steamer New York*

#### **4.4 – Walking Beam**

The walking beam, also known as a "vertical beam", "overhead beam", or simply "beam", was another early adaptation of the beam engine, but its use was confined almost entirely to the United States.

After its introduction, the walking beam quickly became the most popular engine type in America for inland waterway and coastal service, and the type proved to have remarkable longevity, with walking beam engines still being occasionally manufactured as late as the 1940s.

In marine applications, the beam itself was generally reinforced with iron struts that gave it a characteristic diamond shape, although the supports on which the beam rested were often built of wood. The adjective "walking" was applied because the beam, which rose high above the ship's deck, could be seen operating, and its rocking motion was (somewhat fancifully) compared to a walking motion.

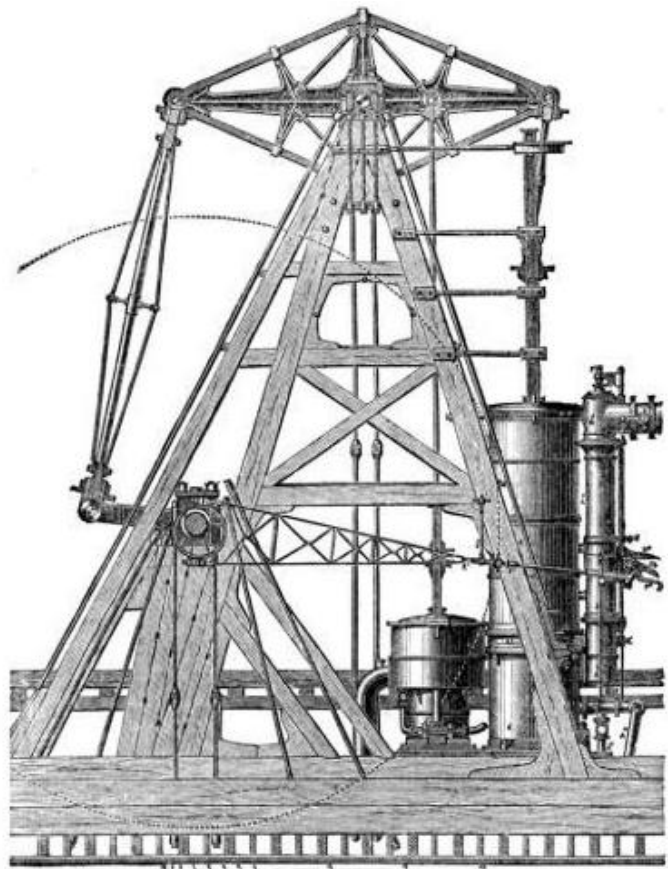

*Basic Diagram of a Walking Beam Engine*

---

Walking beam engines were a type of paddlewheel engine and were rarely used for powering propellers. They were used primarily for ships and boats working in rivers, lakes and along the coastline, but were a less popular choice for seagoing vessels because the great height of the engine made the vessel less stable in heavy seas. They were also of limited use militarily, because the engine was exposed to enemy fire and could thus be easily disabled.

Walking beam engines remained popular with American shipping lines and excursion operations right into the early 20th century. Although the walking beam engine was technically obsolete in the later 19th century, it remained popular with excursion steamer passengers who expected to see the "walking beam" in motion.

There were also technical reasons for retaining the walking beam engine in America, as it was easier to build, requiring less precision in its construction. Wood could be used for the main frame of the engine, at a much lower cost than typical practice of using iron castings for more modern engine designs. Fuel was also much cheaper in America than in Europe, so the lower efficiency of the walking beam engine was less of a consideration.

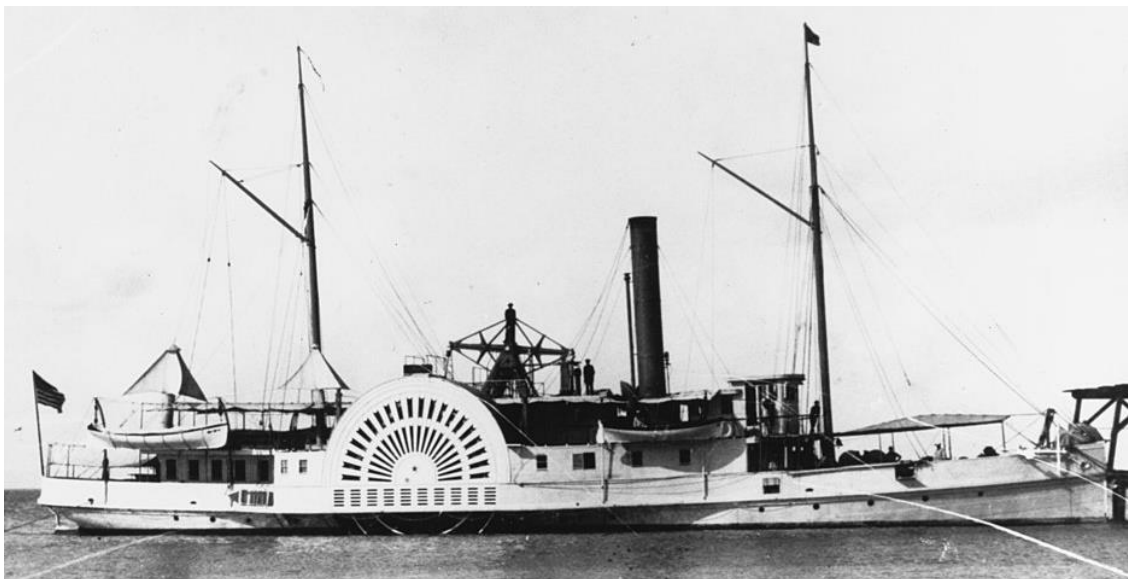

*USS Delaware 1861*

---

## 4.5 – Steeple

The steeple engine, sometimes referred to as a "crosshead" engine, was an early attempt to break away from the beam concept common to both the walking beam and side-lever types, and come up with a smaller, lighter, more efficient design.

In a steeple engine, the vertical oscillation of the piston is not converted to a horizontal rocking motion as in a beam engine, but is instead used to move an assembly, composed of a crosshead and two rods, through a vertical guide at the top of the engine, which in turn rotates the crankshaft connecting rod below.

In early examples of the type, the crosshead assembly was rectangular in shape, but over time it was refined into an elongated triangle.

The triangular assembly above the engine cylinder gives the engine its characteristic "steeple" shape, hence the name.

Steeple engines were tall like walking beam engines, but much narrower laterally, saving both space and weight. Because of their height and high center of gravity, they were, like walking beams, considered less appropriate for oceangoing service, but they remained highly popular for several decades, especially in Europe, for inland waterway and coastal vessels.

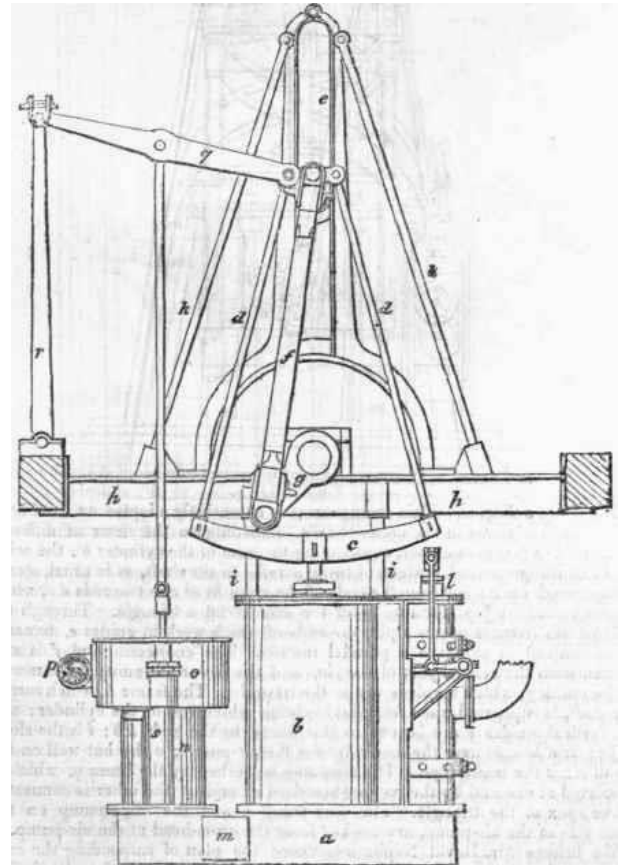

*Diagram of the Steeple Engine*

Steeple engines began to appear in steamships in the 1830s and the type was perfected in the early 1840s by the Scottish shipbuilder David Napier. The steeple engine was gradually superseded by the various types of direct-acting engines.

---

## 4.6 - Siamese

The Siamese engine, also referred to as the "double cylinder" or "twin cylinder" engine, was another early alternative to the beam or side-lever engine. This type of engine had two identical, vertical engine cylinders arranged side-by-side, whose piston rods were attached to a common, T-shaped crosshead.

The vertical arm of the crosshead extended down between the two cylinders and was attached at the bottom to both the crankshaft connecting rod and to a guide block that slid between the vertical sides of the cylinders, enabling the assembly to maintain the correct path as it moved.

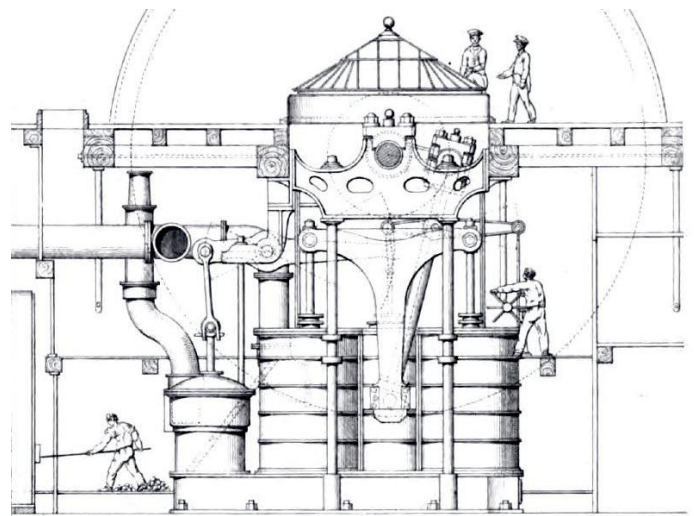

*Siamese Engine - HMS Retribution*

The Siamese engine was invented by British engineer Joseph Maudslay (son of Henry), but although he invented it after his oscillating engine, it failed to achieve the same widespread acceptance, as it was only marginally smaller and lighter than the side-lever engine it was designed to replace. It was however used on a number of mid-century warships.

## 4.7 – Direct Acting

There are two definitions of a direct-acting engine encountered in 19th-century literature. The earlier definition applies the term "direct-acting" to any type of engine other than a beam (i.e., walking beam, side-lever or grasshopper) engine. The later definition only uses the term for engines that apply power directly to the crankshaft via the piston rod and/or connecting rod. Unless otherwise noted, this project will be utilizing the later definition.

Unlike the side-lever or beam engine, a direct-acting engine could be readily adapted to power either paddlewheels or a propeller. As well as offering a lower profile, direct-acting engines had the advantage of being smaller and weighing considerably less than beam or side-lever engines.

The Royal Navy found that on average a direct-acting engine (early definition) weighed 40% less and required an engine room only two thirds the size of that for a side-lever of equivalent power. One disadvantage of such engines is that they were more prone to wear and tear and thus required more maintenance.

## 4.8 – Oscillating

An oscillating engine was a type of direct-acting engine that was designed to achieve further reductions in engine size and weight. Oscillating engines had the piston rods connected directly to the crankshaft, taking away the need for connecting rods.

To achieve this, the engine cylinders were not immobile as in most engines, but secured in the middle by trunnions that let the cylinders themselves pivot back and forth as the crankshaft rotated—hence the term, oscillating. Steam was supplied and exhausted through the trunnions.

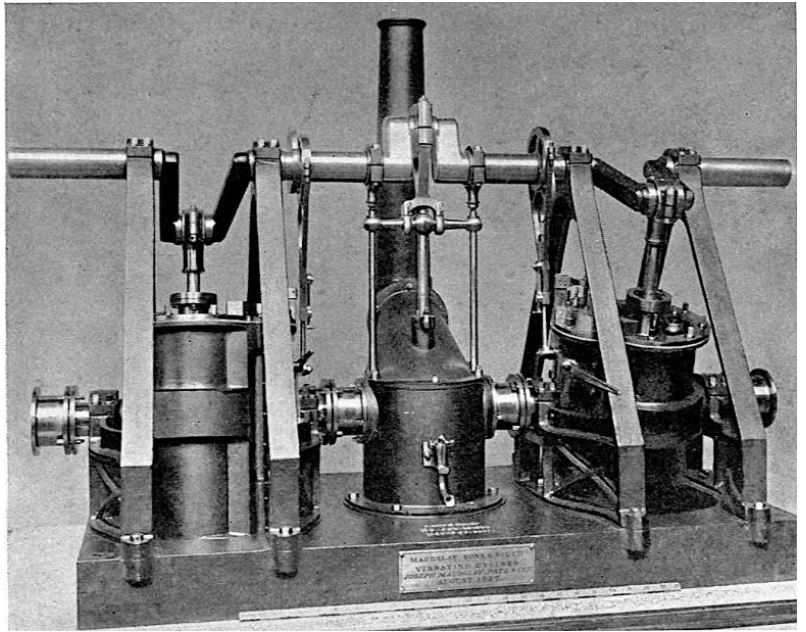

*Maudslay Oscillating Engine Model*

The oscillating motion of the cylinder was usually used to line up ports in the trunnions to direct the steam feed and exhaust to the cylinder at the correct times. However, separate valves were often provided, controlled by the oscillating motion. This let the timing be varied to enable expansive working. This provides simplicity but still retains the advantages of compactness.

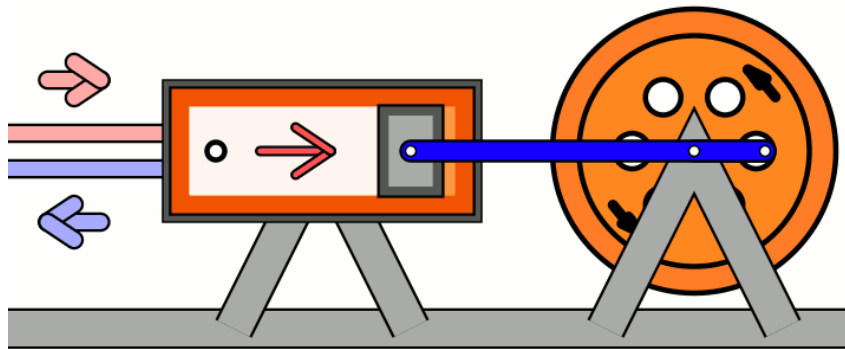

*Oscillating Steam Engine Cylinder Animation*

The first patented oscillating engine was built by Joseph Maudslay in 1827, but the type is considered to have been perfected by John Penn. Oscillating engines remained a popular type of marine engine for much of the 19th century.

---

## 4.9 – Trunk

The trunk engine, another type of direct-acting engine, was originally developed as a means of reducing an engine's height while retaining a long stroke. (A long stroke was considered important at this time because it reduced the strain on components.)

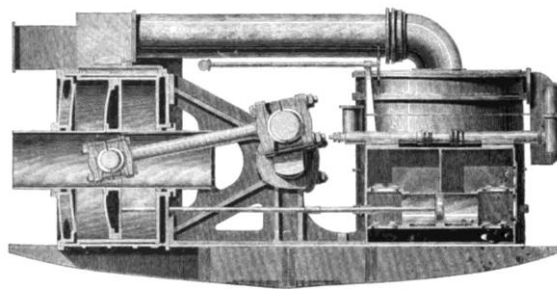

*Trunk Engine Illustration from Johnson 1918*

A trunk engine locates the connecting rod within a large-diameter hollow piston rod. This "trunk" carries almost no load. The interior of the trunk is open to outside air, and is wide enough to accommodate the side-to-side motion of the connecting rod, which links a gudgeon pin at the piston head to an outside crankshaft.

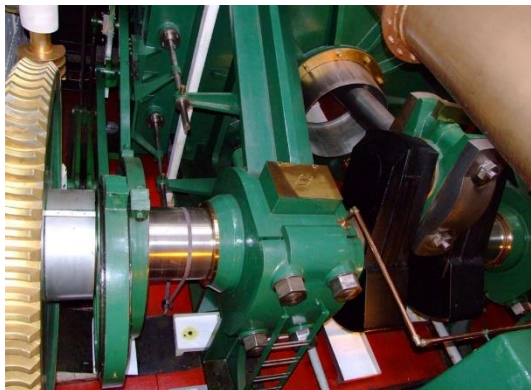

*HMS Warrior Trunk Engine*

The walls of the trunk were either bolted to the piston or cast as one piece with it, and moved back and forth with it. The working portion of the cylinder is annular or ring-shaped, with the trunk passing through the center of the cylinder itself.

Early examples of trunk engines had vertical cylinders. However, ship builders quickly realized that the type was compact enough to lay horizontally across the keel. In this configuration, it was very useful to navies, as it had a profile low enough to fit entirely below a ship's waterline, as safe as possible from enemy fire. The type was generally produced for military service by John Penn.

Trunk engines were common on mid-19th century warships. They also powered commercial vessels, where—though valued for their compact size and low center of gravity—they were expensive to operate. Trunk engines, however, did not work well with the higher boiler pressures that became prevalent in the latter half of the 19th century, and builders abandoned them for other solutions. Trunk engines were normally large, but a small, mass-produced, high-revolution, high-pressure version was produced for the Crimean War. In being quite effective, the type persisted in later gunboats.

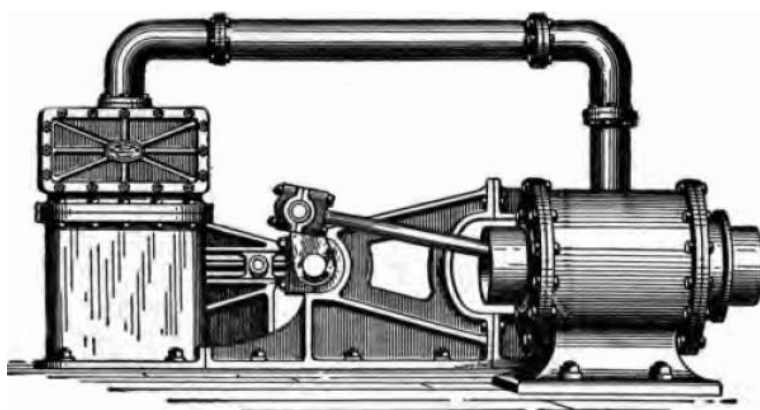

*HMS Bellerophon Trunk Engine*

---

## 4.10 – Vibrating Lever

The vibrating lever, or half-trunk engine, was a development of the conventional trunk engine conceived by Swedish-American engineer John Ericsson. Ericsson needed a small, low-profile engine like the trunk engine to power the U.S. Federal government's monitors, a type of warship developed during the American Civil War that had very little space for a conventional powerplant.

The trunk engine itself was, however, unsuitable for this purpose, because the preponderance of weight was on the side of the engine that contained the cylinder and trunk—a problem that designers could not compensate for on the small monitor warships.

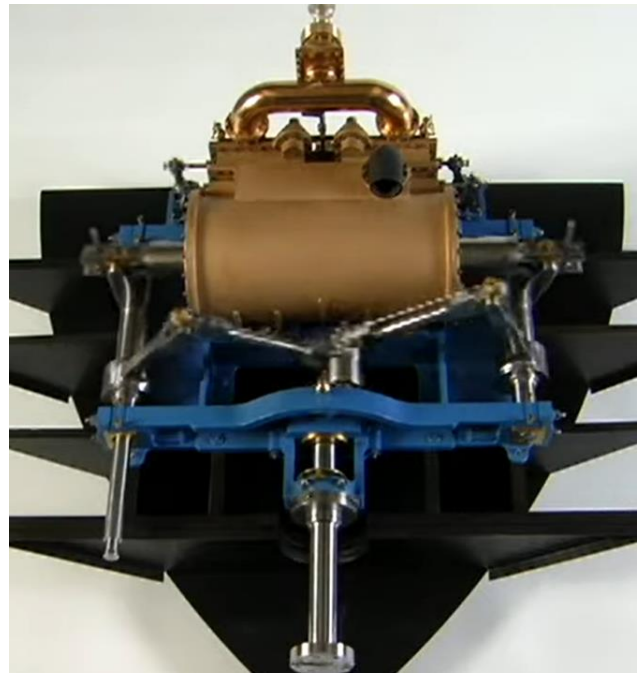

*Modern Model of the USS Monadnock with over 3000 hours of work dedicated to the build*

Ericsson resolved this problem by placing two horizontal cylinders back-to-back in the middle of the engine, working two "vibrating levers", one on each side, which by means of shafts and additional levers rotated a centrally located crankshaft.

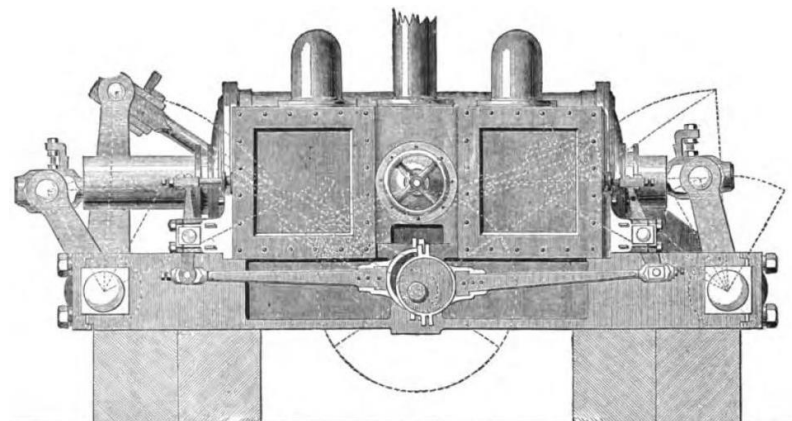

*USS Monitor Monadnock Vibrating Lever Engine*

Vibrating lever engines were later used in some other warships and merchant vessels, but their use was confined to ships built in the United States and in Ericsson's native country of Sweden. They had few advantages over more conventional engines and thus were soon supplanted by other types.

---

## 4.11 – Back Acting

The back-acting engine, also known as the return connecting rod engine, was another engine designed to have a very low profile and looks a lot like a trunk engine. The back-acting engine was in effect a modified steeple engine, laid horizontally across the keel of a ship rather than standing vertically above it.

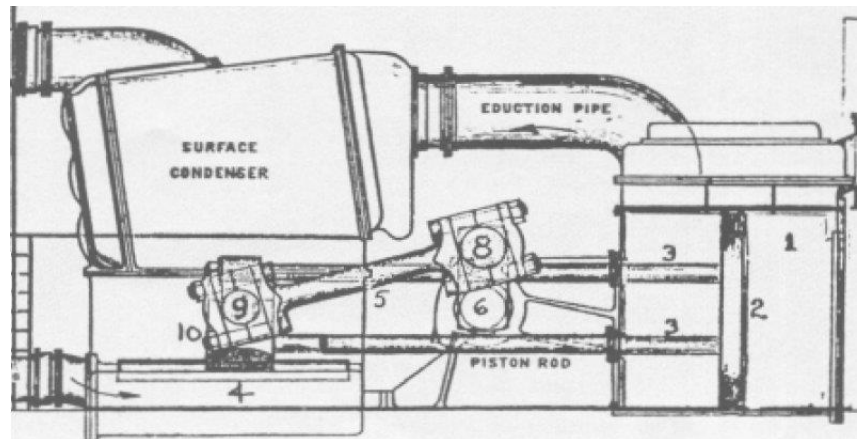

*Diagram of Back-Acting Engine of USS Ranger*

Instead of the triangular crosshead assembly found in a typical steeple engine however, the back-acting engine generally used a set of two or more elongated, parallel piston rods terminating in a crosshead to perform the same function.

The term "back-acting" or "return connecting rod" derives from the fact that the connecting rod "returns" or comes back from the side of the engine opposite of the engine cylinder to rotate a centrally located crankshaft.

Back-acting engines were another type of engine popular in both warships and commercial vessels in the mid-19th century, but like many other engine types in this era of rapidly changing technology, they were eventually abandoned for other solutions. There is only one known surviving back-acting engine, that of the TV Emery Rice (formerly USS Ranger), now the centerpiece of a display at the American Merchant Marine Museum.



## 4.12 – Vertical

As steamships grew steadily in size and tonnage through the course of the 19th century, the need for low profile, low center-of-gravity engines correspondingly declined. Freed increasingly from these design constraints, engineers were able to revert to simpler, more efficient and more easily maintained designs. The result was the growing dominance of the so-called "vertical" engine (more correctly known as the vertical inverted direct acting engine).

In this type of engine, the cylinders are located directly above the crankshaft, with the piston rod/connecting rod assemblies forming a more or less straight line between the two. The configuration is similar to that of a modern internal combustion engine (one notable difference being that the steam engine is double acting, whereas almost all internal combustion engines generate power only in the downward stroke). Vertical engines are sometimes referred to as "hammer", "forge hammer" or "steam hammer" engines, due to their roughly similar appearance to another common 19th-century steam technology, the steam hammer.

Vertical engines came to supersede almost every other type of marine steam engine toward the close of the 19th century. Because they became so common, vertical engines are not usually referred to as such, but are instead referred to, based upon their cylinder technology, i.e., as compound, triple-expansion, quadruple-expansion etc. The term "vertical" for this type of engine is imprecise, since technically any type of steam engine is "vertical" if the cylinder is vertically oriented. An engine someone describes as "vertical" might not be of the vertical inverted direct-acting type.

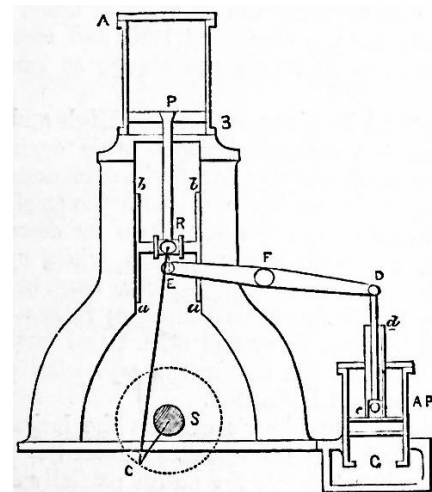

*Vertical Steam Engine Simple Diagram*

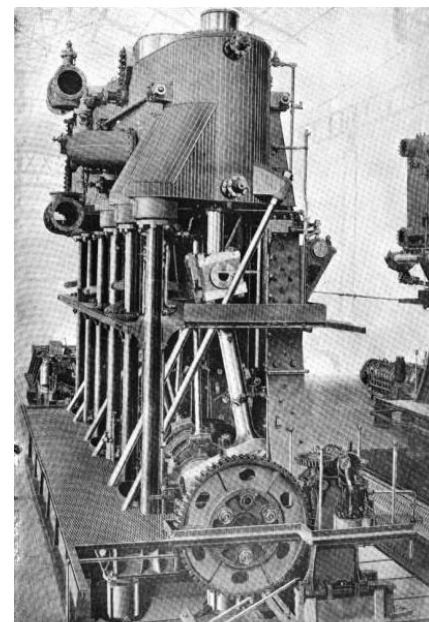

*Vertical Triple-Expansion Engine - USS Wisconsin*

---

## CHAPTER 5 - ENTER THE STEAMSHIP-AN ERA OF FIRSTS

### 5.1 - First Steam-Powered Boat to Operate

Denis Papin FRS was a French physicist, mathematician and inventor, best known for his pioneering invention of the steam digester, the forerunner of the pressure cooker and of the steam engine.

While in Marburg in 1690, having observed the mechanical power of atmospheric pressure on his 'digester', Papin built a model of a piston steam engine, the first of its kind.

In 1705 while teaching mathematics at the University of Marburg, he developed a second steam engine with the help of Gottfried Leibniz, based on an invention by Thomas Savery, but this used steam pressure rather than atmospheric pressure.

In 1705, he constructed a ship powered by his steam engine, mechanically linked to paddles. This made him the first to construct a steam-powered boat (or vehicle of any kind).

He decided to steam the boat down the river Fulda to the river Weser. Any boat making this trip was forced to stop at the city of Münden.

At that time, river traffic on the Fulda and Weser was the monopoly of a guild of boatmen. Guild members did not want competition from Papin's steamboat and smashed it with his steam engine to pieces.

Later, at the iron foundry in Veckerhagen (now Reinhardshagen), he cast the world's first steam cylinder.

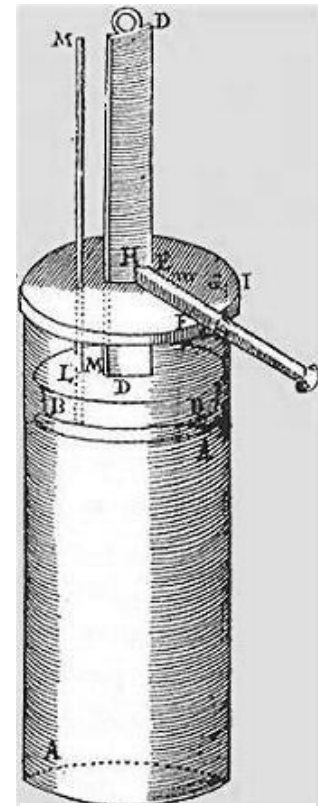

*The first piston steam engine  
1690*

### 5.2 - First British Proposition to apply Steam Power to Naval purposes

Jonathan Hulls, who in 1736 obtained a patent for propelling a boat by steam, which, however, was never put to practical experiment, is beyond doubt the first Englishman who proposed to apply that power to naval purposes.

### 5.3 - Marquis de Jouffroy's Steamboat

Another serious effort was carried out by a French nobleman, Claude-François-Dorothee, marquis de Jouffroy d'Abbans, on the Doubs River at Baum-des-Dames in the Franche-Comté in 1776. This trial was not a success, but in 1783 Jouffroy carried out a second trial with a much larger engine built three years earlier at Lyon.

---

This larger boat, the *Pyroscaphe*, was propelled by two paddle wheels, substituted for the two “duck’s feet” used in the previous trial. The trial took place on the gentle river Saône at Lyon, where the overburdened boat of 327,000 pounds moved against the current for some 15 minutes before it disintegrated from the pounding of the engines. There were subsequent French experiments, but further development of the steamboat was impeded by the French Revolution.



*Model made by Jouffroy in 1784 to show the French Science Academy the engine and paddle wheels used on the Pyroscaphe. The model is now in the National Maritime Museum in Paris.*

## 5.4 - John Fitch

At the same time, another American, John Fitch, a former clockmaker from Connecticut, began experimenting with his vision of a steamboat. After much difficulty in securing financial backers and in finding a steam engine in America, Fitch built a boat that was given a successful trial in 1787. By the summer of 1788 Fitch and his partner, Henry Voight, had made repeated trips on the Delaware River as far as Burlington, 20 miles above Philadelphia, the longest passage then accomplished by a steamboat.

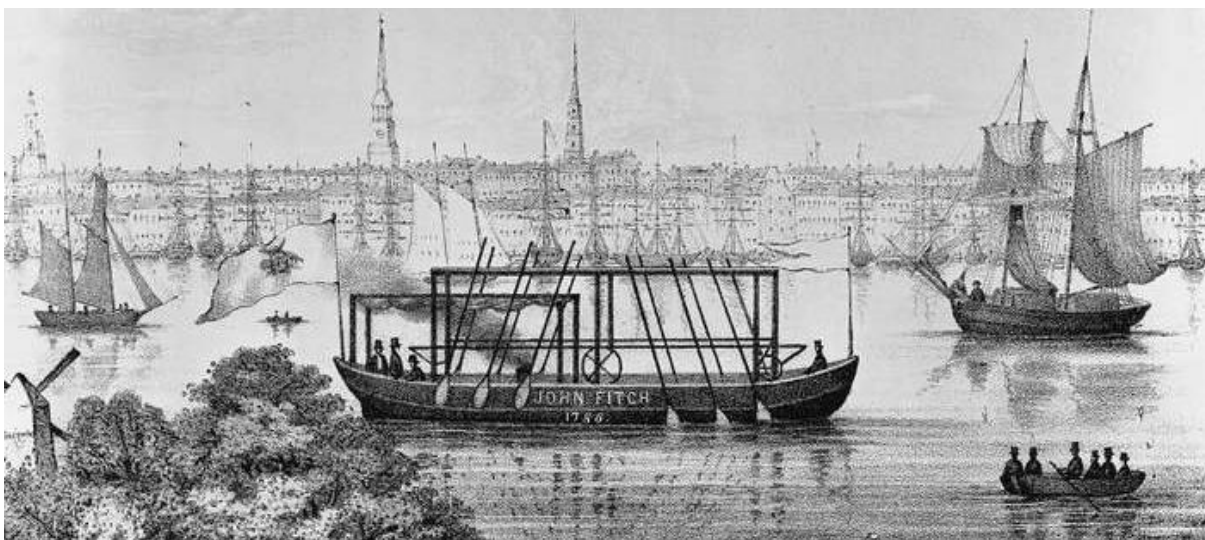

*Illustration of an early version of John Fitch's steamboat.*

---

## 5.5 - Some British Experiments

British inventors were active in this same period. Fitch ultimately sought to advance his steamboat by going to England and Robert Fulton spent more than a decade in France and Britain promoting first his submarine and later his steamboat.

In 1788 William Symington, son of a millwright in the north of England, began experimenting with a steamboat that was operated at five miles per hour, faster than any previous trials had accomplished. He later claimed speeds of six and a half and seven miles per hour, but his steam engine was thought too weak to serve, and for the time his efforts were not rewarded.

In 1801 Symington was hired by Lord Dundas, a governor of the Forth and Clyde Canal, to build a steam tug; the Charlotte Dundas was tried out on that canal in 1802. It proved successful in pulling two 70-ton barges the 19 1/2 miles to the head of the canal in six hours. The governors, however, fearing bank erosion, forbade its use on that route, and British experiments failed to lead further for some years.

## 5.6 - The First Screw Propellers Emerge

The key innovation that made ocean-going steamers viable was the change from the paddle-wheel to the screw-propeller as the mechanism of propulsion. These steamships quickly became more popular, because the propeller's efficiency was consistent regardless of the depth at which it operated. Being smaller in size and mass and being completely submerged, it was also far less prone to damage.

James Watt of Scotland is widely given credit for applying the first screw propeller to an engine at his Birmingham works, an early steam engine, beginning the use of a hydrodynamic screw for propulsion, although this was done in a lab and never been put into practice on actual water.

In 1804, Colonel John Stevens launched his boat, Little Juliana, a 25-foot Whitehall style vessel he used to demonstrate his high-pressure steam boiler, twin screw propeller configuration (or two counter-rotating propellers) and novel engine.

Little Juliana successfully navigated the Hudson River and amazed onlookers by travelling without a visible means of propulsion. This was the first real attempt to use propellers.

The boat, named for Stevens' daughter, and its power/propulsion system was the precursor of the modern steam propeller drive ship that carries 90% of the world's goods today. Its twin screws, high-pressure boiler and advanced propeller design were decades ahead of their time. Stevens' experimental boats, including Little Juliana, pioneered steam navigation in America and attracted significant attention.

In October 1811, Stevens' ship the Juliana began operation as the first steam-powered ferry (service was between New York, New York and Hoboken, New Jersey).

Another experimenter, John Stevens, decided to move his steamboat Phoenix from the Hudson to the Delaware River. In June 1809 a 150-mile run in the ocean between Perth Amboy, New Jersey, and Delaware Bay was the first ocean voyage carried out by a steamboat. Phoenix was a sidewheel steamboat built in 1807 and measured 50 feet (15 m) long, 12 feet (3.7 m) wide and 7 feet (2.1 m) deep. She had 25 cabin berths and additional 12 berths in steerage.

---

## 5.7 - First commercial navigation outside the U.S.

The first commercial steam navigation outside the United States began in 15 August 1812 when Henry Bell, the proprietor of the Helensburgh Baths located on the Clyde below Glasgow, added a steamboat, the Comet, to carry his customers from the city.

The PS (paddle steamer) Comet travelled on the River Clyde between Glasgow and Greenock and was the first commercially successful steamboat service in Europe.



*Replica of PS Comet in Port Glasgow town center*

## 5.8 - Robert Fulton's Advances

Robert Fulton, an American already well known in Europe, began to gain headway in developing a steamboat. British historians have tended to deny his contributions and assign them to his supposed piracy of British inventions, which was later proven false. Fulton's "invention" of the steamboat depended fundamentally on his ability to make use of Watt's patents for the steam engine, as Fitch could not.

Having experimented on steamboats for many years, by the first decade of the 19th century Fulton had determined that paddle wheels were the most efficient means of propelling a boat, a decision appropriate to the broad estuarine rivers of the Middle Atlantic states.

Fulton had built and tested on August 9, 1803, a steamboat that ran four times to the Quai de Chaillot on the Seine River in Paris. As it operated at no more than 2.9 miles per hour—slower than a brisk walk—he considered these results at best marginal.

Fulton returned to the United States in December 1806 to develop a successful steamboat with his partner Robert Livingston. A monopoly on steam boating in New York state had been previously granted to Livingston, a wealthy Hudson Valley landowner and American minister to France. On August 17, 1807, what was then called simply the "North River Steamboat" steamed northward on the Hudson from the state prison.

After spending the night at Livingston's estate of Clermont (whose name has ever since erroneously been applied to the boat itself) the "North River Steamboat" reached Albany eight hours later after a run at an average speed of five miles per hour (against the flow of the Hudson River).



*A replica of Robert Fulton's Clermont-North River Steamboat of Clermont the first commercially successful steamboat*

---

This was a journey of such length and relative mechanical success that there can be no reasonable question it was the first steamboat put in public service.

Commercial service began immediately, and the boat made one and a half round-trips between New York City and Albany each week. Many improvements were required in order to establish scheduled service, but from the time of this trial forward Fulton and Livingston provided uninterrupted service, added steamboats, spread routes to other rivers and finally, in 1811, attempted to establish steamboat service on the Mississippi River.

## **5.9 - The first Ship to cross an ocean using hybrid power sidewheel steamer/sailing ship**

Built in the port of New York for the Savannah Steam Ship Company in 1818, the Savannah was 98.5 feet long (30m) with a 25.8-foot beam (7.8m), a depth of 14.2 feet (4.3m), and a displacement of 320 tons. She was a hybrid sailing ship/sidewheel steamer. Because of a depression in trade, the owners sold the boat in Europe where economically constructed American ships were the least expensive on the market and were widely seen as the most advanced in design.

Unable to secure either passengers or cargo, the Savannah became the first ship to employ steam in crossing an ocean transiting mainly under sail power. At 5:00 in the morning on May 24, 1819, it set sail from Savannah.

After taking on coal at Kinsale in Ireland, it reached Liverpool on July 20, after 27 days and 11 hours; the engine was used to power the paddle wheels for 85 hours. Subsequently the voyage continued to Stockholm and St. Petersburg, but at neither place was a buyer found; it thus returned to Savannah, under sail because coal was so costly, using steam only to navigate the lower river to reach the dock at Savannah itself.

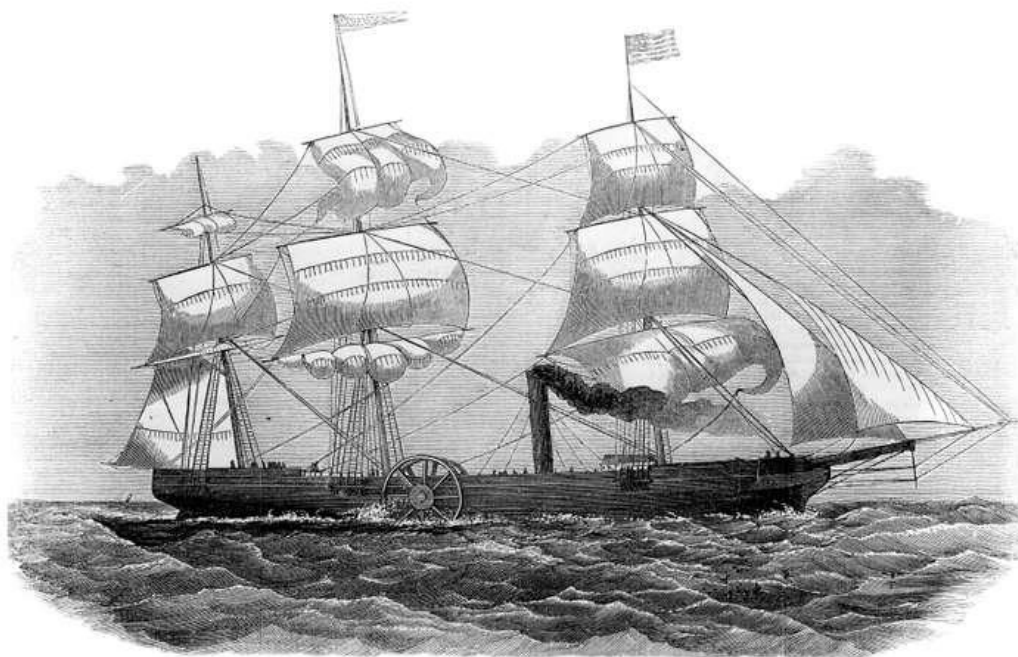

*The American Paddleship Savannah, which in 1819 became the first ship to use steam power in crossing an ocean. From a wood engraving, 1854.*

---

## 5.10 – The First Iron Steamship

Aaron Manby was a landmark vessel in the science of shipbuilding as the first iron steamship to go to sea. She was built by Aaron Manby (1776–1850) at the Horseley Ironworks. She made the voyage to Paris in June 1822 under Captain (later Admiral) Charles Napier, with Aaron's son Charles on board as an engineer. It had a length of 32m and a beam of 5.2m, 7.0m with the paddlewheels included.

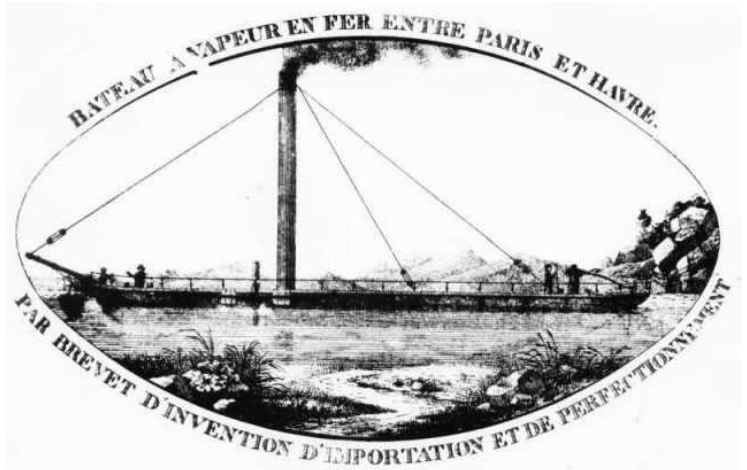

*A picture of Aaron Manby in French Service*



*Aaron Manby Silver coin 40g*

It had an oscillating cylinder steam engine installed with a power of 30 hp (22 kW), max speed was 8 knots-15km/h. The use of iron plates for the hull, in place of wood, was widely copied in shipbuilding during the following decades.

## 5.11 – Stevens Family Innovations

Throughout the first half of the nineteenth century, the Stevens family made numerous contributions to the steamship's design. Improvements included advances in boilers, hulls, and pressure valves. In 1822 Robert Stevens designed the ferry slip for the Hoboken Steamboat Ferry Company. Long piles were driven into the river bed and hardwood fenders were attached to them. This design made it simpler for ferries to dock in strong tides, and was widely adopted. In 1823 the family launched the first double-ended propeller-driven ferryboat, the Bergen, which made paddlewheel boats obsolete.

Robert would build numerous steam ferries, increasing the speed of each successive craft from 8 miles per hour in 1815 to 15 mph in 1832. Robert's New Philadelphia, with an innovative bow that cut through water efficiently, was able to complete the trip from Albany to New York City between dawn and dusk.

---

## 5.12 – The First Transatlantic Steamships entirely under steam power

The first ship to make the transatlantic trip substantially under steam power may have been the British-built Dutch-owned *Curaçao*, a wooden 438-ton vessel built in Dover and powered by two 50 hp engines, which crossed from Hellevoetsluis, near Rotterdam on 26 April 1827 to Paramaribo, Surinam on 24 May, spending 11 days under steam on the way out and more on the return.

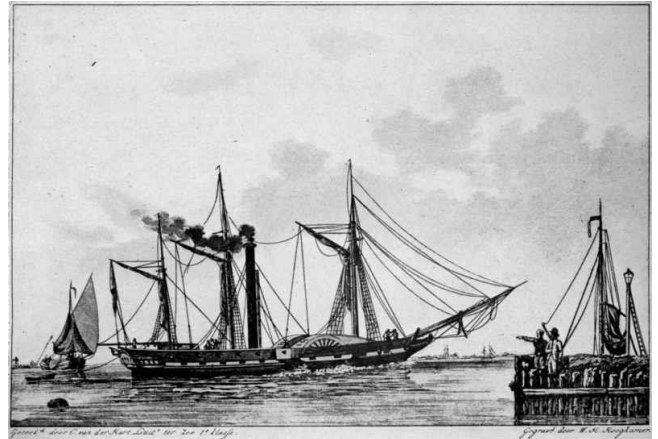

*Steamship Curaçao 1827*

SS *Royal William* was a Canadian side-wheel paddle steamship that is sometimes credited with the first crossing of the Atlantic Ocean to be made almost entirely under steam power, in 1833, using sails only during periods of boiler maintenance. The steamer had only minor auxiliary sails.

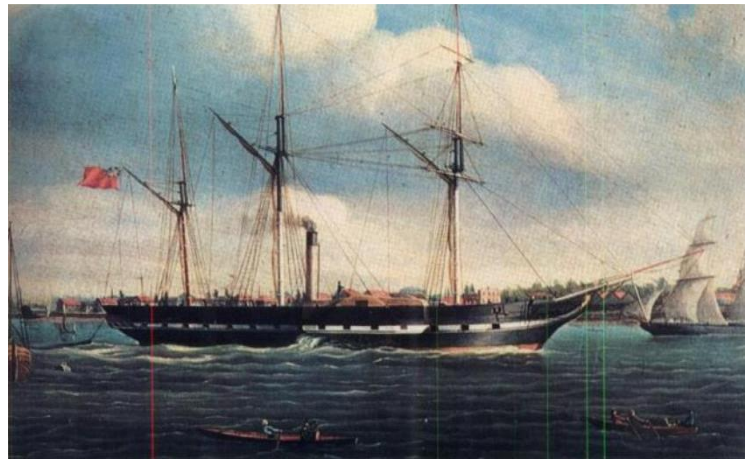

*A painting of SS Royal William drawn by James Goudie*

She was the largest passenger ship in the world from 1831 to 1839. The 1,370-ton SS *Royal William* (named after the ruling monarch, William IV) was 160 feet (49 m) long, 44 feet (13 m) wide and had a draught of 17¾ft, a large steamship for the time.

*Sirius*, was the first ship to cross the Atlantic entirely under steam. Built originally for service in the Irish Sea, the 703-ton *Sirius*, a side-wheeler, was chartered by the British & American Steam Navigation Company and sailed from London to New York by way of Cork in 1838 with 40 passengers. Her fuel ran out just short of her destination, but her captain, determined to complete the passage under steam, refused to hoist the ship's sails and, instead, fed spars into the furnace. Sandy Hook, New Jersey, was sighted in time to avert a potential mutiny, and the *Sirius* beat the much larger *Great Western* to New York by a few hours.

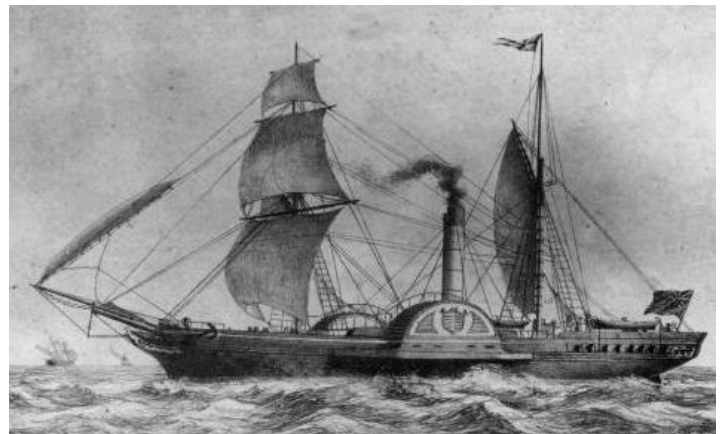

*SS Sirius 1837*

In addition to establishing a crossing record, the *Sirius* introduced an important technical innovation, a condenser to recover the fresh water used in the boiler.



---

### 5.13 – The First steamship made, purpose-built for crossing the Atlantic

SS Great Western of 1838, was a wooden-hulled paddle-wheel steamship built of Dantzic pine, the first steamship purpose-built for crossing the Atlantic, and the initial unit of the Great Western Steamship Company. She was the largest passenger ship in the world from 1837 to 1839. Designed by Isambard Kingdom Brunel, Great Western proved satisfactory in service and was the model for all successful wooden Atlantic paddle-steamers. She was capable of making record Blue Riband voyages as late as 1843.

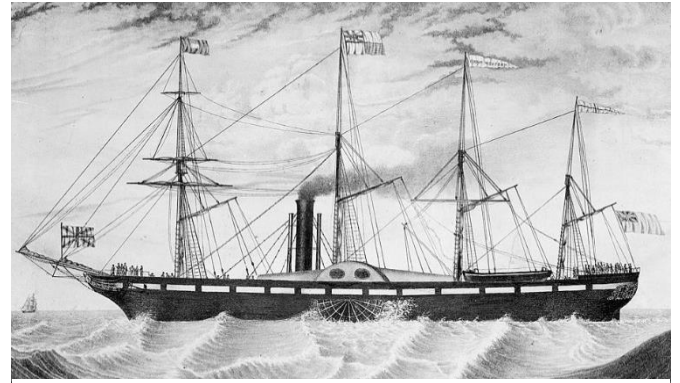

*SS Great Western*

Great Western worked in New York for 8 years until her owners went out of business. Her displacement was 2300 tons, she had a length of 71.6m, beam of 17.59m, she had 750hp (560 kW), her speed was 8.5knots, she had a crew of 60 and her capacity was 128 passengers in the 1<sup>st</sup> class, plus 20 servants.

### 5.14 – The First Screw Propeller Steamship

SS Archimedes was a steamship built in Great Britain in 1839. She is notable for being the world's first steamship to be driven by a screw propeller.

Archimedes had considerable influence on ship development, encouraging the adoption of screw propulsion by the Royal Navy, in addition to her influence on commercial vessels.



*SS Archimedes*

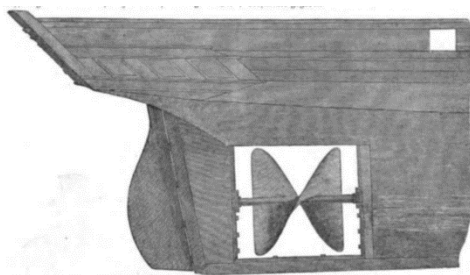

*The Screw propeller of Archimedes as fitted in the stern of the ship*

The ship was 125 feet (38 m) long, 22 1/2 feet (6.9 m) feet wide. Her propulsion stats were 1 x full helix, single turn, single threaded iron propeller operating at 130–150 rpm, plus auxiliary sails. Her speed was about 10 mph (16 km/h) (under steam).

---

## 5.15 – The First Screw Propeller Steamship to cross the Atlantic

She was the longest passenger ship in the world from 1845 to 1854. She was designed by Isambard Kingdom Brunel (1806–1859), for the Great Western Steamship Company's transatlantic service between Bristol and New York City. While other ships had been built of iron or equipped with a screw propeller, Great Britain was the first to combine these features in a large ocean-going ship. She was the first iron steamer to cross the Atlantic Ocean, which she did in 1845, in just 14 days.



*The SS Great Britain 1843*

The ship was 322 ft (98 m) in length and had a 3,400-ton displacement. She was powered by two inclined 2-cylinder engines of the direct-acting type. She was also provided with secondary masts for sail power. The four decks provided accommodation for a crew of 120, plus 360 passengers who were provided with cabins, dining and promenade saloons.

When launched in 1843, Great Britain was by far the largest vessel afloat. She was the first screw-propelled steamship to cross the Atlantic Ocean. This vessel laid the foundation of the most successful marine engine type which was later developed and employed in most of the vessels.

## 5.16 – Screw Propeller Warships

Screw propulsion had some obvious potential advantages for warships over paddle propulsion. Firstly, paddlewheels were exposed to enemy fire in combat, whereas a propeller and its machinery were tucked away safely well below deck. Secondly, the space taken up by paddlewheels restricted the number of guns a warship could carry, thus reducing its broadside.

These potential advantages were well understood by the British Admiralty, but it was not convinced that the propeller was an effective propulsion system. It was only in 1840, when the world's first propeller-driven steamship, SS Archimedes, successfully completed a series of trials against fast paddle-wheelers, that the Navy decided to conduct further tests on the technology. For this purpose, the Navy built Rattler.

HMS Rattler was a 9-gun wooden sloop of the Royal Navy and the first British warship to adopt a screw propeller powered by a steam engine.



*HMS Rattler 1843*

---

The sloop USS Princeton was launched after Rattler, but was placed in commission much sooner.

The first USS Princeton was a screw steam warship of the United States Navy. Commanded by Captain Robert F. Stockton, Princeton was launched on September 5, 1843.

Princeton was the first ship with screw propellers powered by an engine mounted entirely below the waterline to protect them from gunfire. Her two vibrating lever engines, designed by Ericsson, were built by Merrick & Towne. They burned hard coal and drove a 14 ft (4.3 m) six-bladed screw.



*USS Princeton*

She had a displacement of 969 tons, a length of 50m, a beam of 9.3m and a draft of 5.2m. Her speed averaged around 7kn (13km/h) and she used steam and auxiliary sails as a means of propulsion.

### **5.17 – The Largest ship of her time**

SS Great Eastern was an iron sailing steamship designed by Isambard Kingdom Brunel, and built by J. Scott Russell & Co. at Millwall Iron Works on the River Thames, London. She was by far the largest ship ever built at the time of her 1858 launch, and had the capacity to carry 4,000 passengers from England to Australia without refuelling.

Her length of 692 feet (211 m) was only surpassed in 1899 by the 705-foot (215 m) 17,274-gross-ton RMS Oceanic, her gross tonnage of 18,915 was only surpassed in 1901 by the 701-foot (214 m) 21,035-gross-ton RMS Celtic, and her 4,000-passenger capacity was surpassed in 1913 by the 4,935-passenger SS Imperator. She had a speed of 14 knots (26km/h) and 4 steam engines for the paddles plus an additional engine for the propeller, as well as auxiliary sails. Total power was estimated at 8,000hp.

Her iron hull set a standard for most subsequent liners, but her size was too great to be successful in the shipping market of the 1860s.

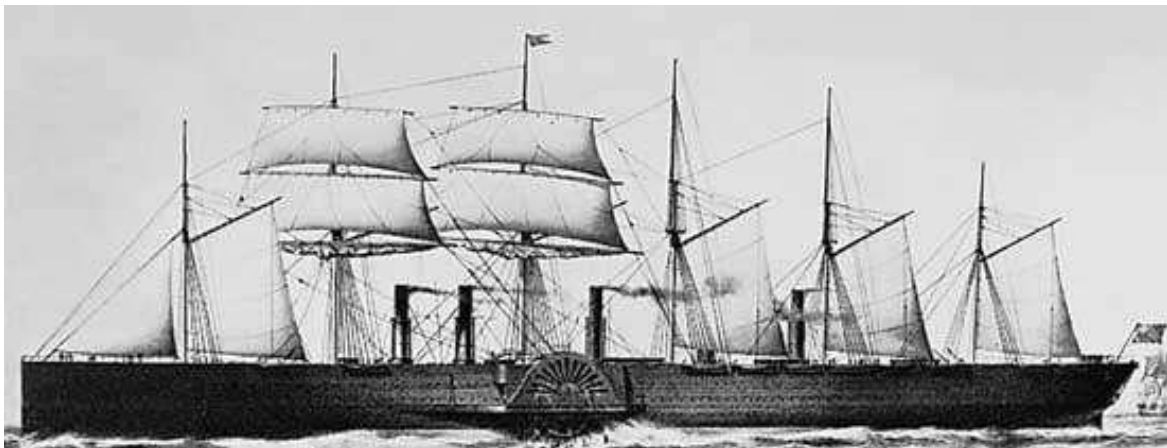

*SS Great Eastern-lithography by T.G. Dutton, 1859*

---

## 5.18 – The last Oceangoing Paddle Steamer

RMS Scotia was a British passenger liner operated by the Cunard Line that won the Blue Riband in 1863 for the fastest westbound transatlantic voyage. She was the last oceangoing paddle steamer, and as late as 1874 she made Cunard's second fastest voyage. Laid up in 1876, Scotia was converted to a twin-screw cable layer in 1879. She served in her new role for twenty-five years until she was wrecked off, at Guam in March 1904. She had 2 masts that hosted the auxiliary sails and 1 twin cylinder side-lever engine that boasted 4000hp (3,000kW). Her length was 120m and her beam 14m.

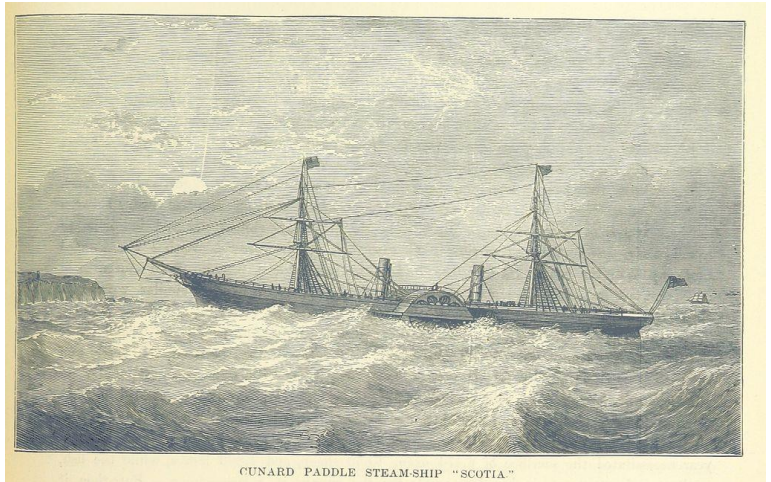

CUNARD PADDLE STEAMSHIP "SCOTIA"

*RMS Scotia underway*

## 5.19 – The First Ship to be powered by a Triple Expansion Steam Engine

SS Aberdeen was a British cargo liner launched in 1882. She was the first ship to be successfully powered by a triple expansion steam engine. She was sold in 1906 to the Ottoman government. She served as a Turkish troopship in World War I until a British submarine sank her in 1915.

In Aberdeen, Kirk installed a refined version of his engine, resulting in a ship that has been described as "one of the masterpieces of British shipbuilding".

This ship proved the advantages of the new type of engine, which would continue to power major vessels throughout the world for the next seventy years.



*SS Aberdeen built in 1881*

She had a length of 110m, a beam of 13.5m, her passenger capacity was capped at 695 and her average speed was 12 knots.

---

## 5.20 – The First Battleship to be powered by a Triple Expansion Steam Engine

HMS Victoria was the lead ship in her class of two battleships of the Royal Navy. She was the first battleship to be propelled by triple-expansion steam engines. These were constructed by Humphrys, Tennant and Company of Deptford and produced 12,000 hp (8,900 kW).

Her speed was 17.3 knots (32 km/h), she had a length of 100 m, a beam of 21 m and a draught of 8.15 m. Her displacement was 11,200 tons. She accidentally rammed and sank on 22 June 1893.

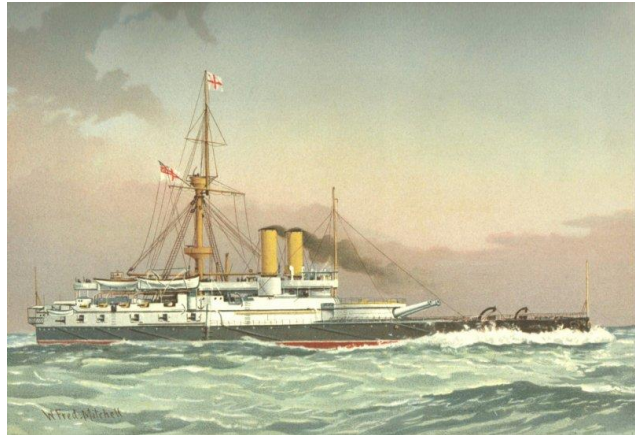

*HMS Victoria Drawing by William Frederick Mitchell*

The ship was nicknamed 'the Slipper' (or when with her sister ship Sans Pareil, also attached to the Mediterranean squadron, 'the pair of Slippers') because of a tendency for her low foredeck to disappear from view in even slight seas, and especially, as a result of the low forward deck and raised aft superstructure, for the two ships' humorously perceived resemblance to the indoor footwear.

## 5.21 – The First Steam Turbine-Powered Steamship

Turbinia was the first steam turbine-powered steamship. Built as an experimental vessel in 1894, she was easily the fastest ship in the world at that time.

Turbinia was demonstrated dramatically at the Spithead Navy Review in 1897 and set the standard for the next generation of steamships, the majority of which would be turbine powered.

The vessel is currently located at the Discovery Museum in Newcastle upon Tyne, North East England.

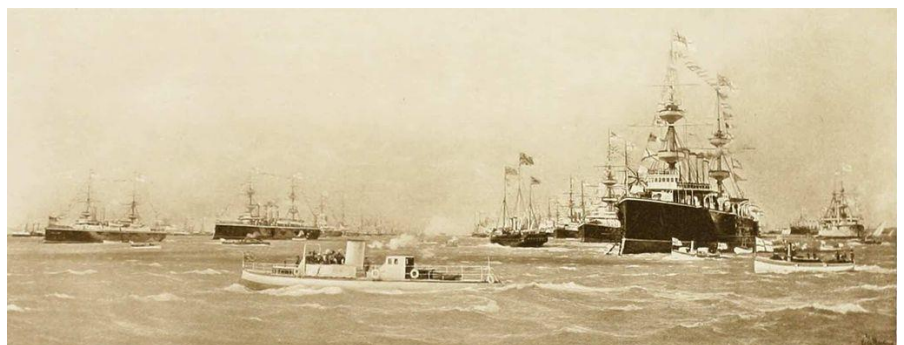

*Turbinia at the Spithead Navy Review, 1897*

---

Photographer and cinematographer Alfred J. West took several photographs of Turbinia travelling at full speed at the review. He was subsequently invited by Sir Charles Parsons to film and photograph the vessel within the River Tyne and the adjacent North Sea; the pictures captured remain the defining image of “Turbinia at speed”. She had a beam of 2.7m, her length was 31.93m, her draught 0.91m and her speed reached a whopping 34.5kn (63.9km/h). She was by far the fastest ship of her time.

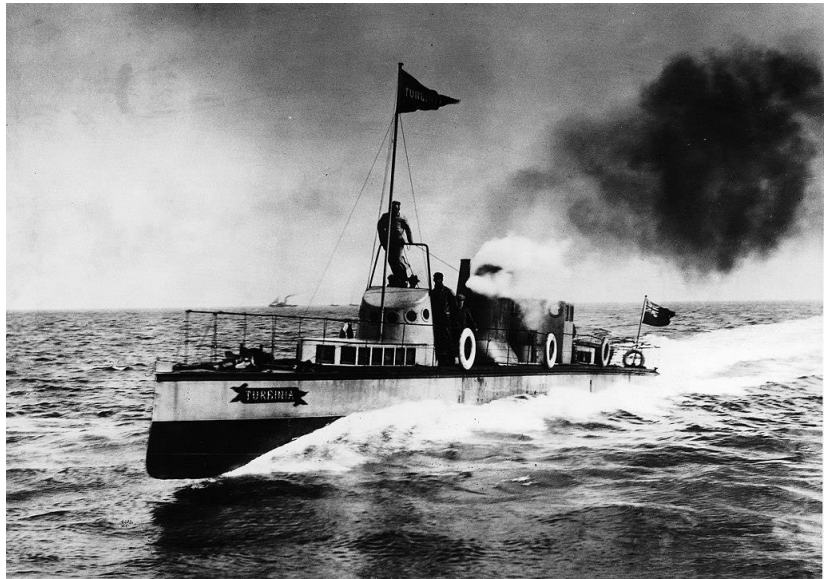

*Turbinia at Speed*

## **5.22 – The First Battleship to employ a Steam Turbine**

HMS Dreadnought was a Royal Navy battleship that revolutionised naval power. The name of the ship, and the class of battleships named after her, means "fear nothing". Dreadnought's entry into service in 1906 represented such an advance in naval technology that her name came to be associated with an entire generation of battleships, the "dreadnoughts", as well as the class of ships named after her. Likewise, the generation of ships she made obsolete became known as "pre-dreadnoughts".



*HMS Dreadnought 1906*

She was the first capital ship to be powered by steam turbines, making her the fastest battleship in the world at the time of her completion. Her launch helped spark a naval arms race as navies around the world, particularly the German Imperial Navy, rushed to match it in the build-up to the First World War.

She had a displacement of 18,410 tons on normal load, a length of 160.6m, a beam of 25m and her draught was 9m. She had 23,000hp (17,000kW) and her speed reached 21knots (39km/h). She was sold for scrap on May 1921.

---

## 5.23 – The Steam Turbine makes its way into ocean liners

RMS Mauretania was an ocean liner designed by Leonard Peskett and built by Wigham Richardson and Swan Hunter for the British Cunard Line, launched on the afternoon of 20 September 1906. She was one of the first ocean liners to use the steam turbine and was soon followed by all subsequent liners.

She was the world's largest ship until the completion of RMS Olympic in 1911. Mauretania became a favourite among her passengers. She captured the Eastbound Blue Riband on her maiden return voyage in December 1907, then claimed the Westbound Blue Riband for the fastest transatlantic crossing during her 1909 season. She held both speed records for 20 years.

She had an impressive length of 240.8m, a beam of 26.8m, a draft of 10.1m, 8 decks and 802 crewmembers. Her speed averaged around 24 knots (44km/h). She could accommodate 2,165 passengers: 563 first class, 464 second class, 1,138 third class.

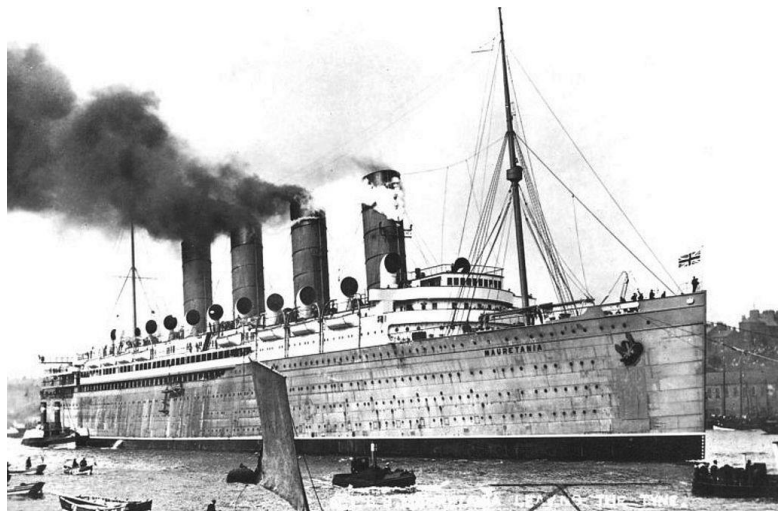

*RMS Mauretania of the River Tyne, 1907*

## 5.24 – The First Turbo-Electric Battleship

USS New Mexico (BB-40) was a battleship in service with the United States Navy from 1918 to 1946. She was the lead ship of a class of three battleships, and the first ship to be named after the state of New Mexico.

Her keel was laid down on 14 October 1915 at the New York Navy Yard, she was launched on 23 April 1917, and was commissioned on 20 May 1918.

She was the first ship with a turbo-electric transmission, which helped her reach a cruising speed of 10 knots (19 km/h) and max speed of 21 knots (39 km/h). She had a length of 190m, a beam of 29.69m and a draft of 9.1m.

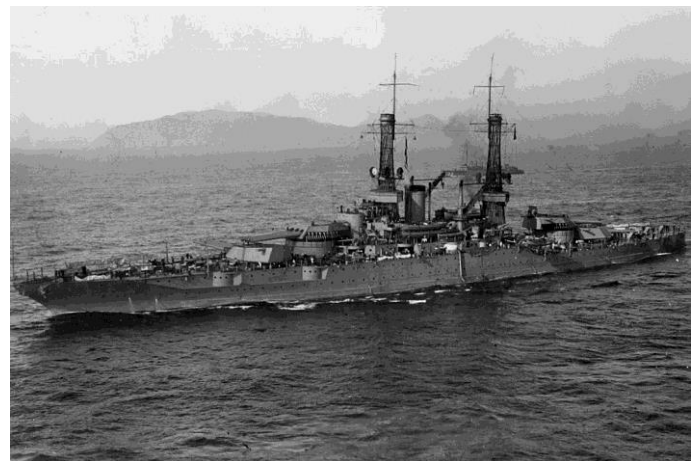

*USS New Mexico, 1921*

---

## 5.25 - The Last Seagoing Passenger Paddle Steamer

PS Waverley is the last seagoing passenger-carrying paddle steamer in the world. Built in 1946, she sailed from Craigendoran on the Firth of Clyde to Arrochar on Loch Long until 1973. Bought by the Paddle Steamer Preservation Society (PSPS), she has been restored to her 1947 appearance and now operates passenger excursions around the British coast.

She has a length of 73.13m, a beam of 17.45m and her power is 2,100hp (1,566kW). Her speed averages at 14knots (26km/h). She is powered by a triple expansion steam engine and her passenger capacity can go up to 925.

Since 2003, Waverley has been listed in the National Historic Fleet by National Historic Ships UK as "a vessel of pre-eminent national importance".

In 2019, Waverley was withdrawn from service due to boiler problems. An appeal was subsequently launched with a target of £2.3 million to recommission Waverley. It was announced on 11 July 2019 that new boilers had been ordered from Cochran Ltd. Following a successful boiler refit, Waverley returned to sea on 13 August 2020 for sea-trials, and resumed service for a short season starting on 22 August. This was cut short after she crashed into the pier at Brodick on 3 September, damaging her bow.



*The PS Waverley with red lions and yellow funnels in 1970*

## 5.26 – Honorable Mentions of Steamers that wrote History

**RMS Olympic** was a British ocean liner and the lead ship of the White Star Line's trio of Olympic-class liners. Unlike the other ships in the class, Olympic had a long career spanning 24 years from 1911 to 1935. This included service as a troopship during the First World War, which gained her the nickname "Old Reliable". She returned to civilian service after the war, and served successfully as an ocean liner throughout the 1920s and into the first half of the 1930s.

Olympic was the largest ocean liner in the world for two periods during 1911–13, interrupted only by the brief tenure of the slightly larger Titanic in terms of gross tonnage.

She had a length of 269.1m, a beam of 28.3m, her draught was 10.5m, her gross tonnage was 45,324 and she had a speed of 21 knots with a maximum recorded speed of 24.2 knots. She could accommodate 2,435 passengers and 950 crewmembers.

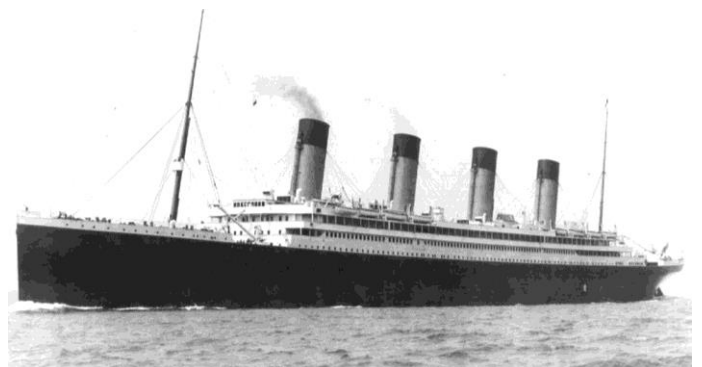

*RMS Olympic during her sea trial*



---

Her installed power was 24 double-ended (six furnace) and 5 single-ended (three furnace) Scotch boilers originally powered by burning coal, later converted to oil powered in 1919. Two four-cylinder triple-expansion reciprocating engines each producing 25,000 hp for the two outboard wing propellers at 85 revolutions per minute. One low-pressure turbine producing 15,000 hp. In total 65,000 hp was produced at maximum revolutions. She had two bronze three-bladed wing propellers and one bronze four-bladed center propeller.

The Olympic was withdrawn from service and sold for scrap in 1935.

**RMS Titanic** was a British passenger liner operated by the White Star Line that sank in the North Atlantic Ocean on 15 April 1912, after striking an iceberg during her maiden voyage from Southampton to New York City. Of the estimated 2,224 passengers and crew aboard, more than 1,500 died, making the sinking at the time the deadliest of a single ship in the West and the deadliest peacetime sinking of a superliner or cruise ship to date.

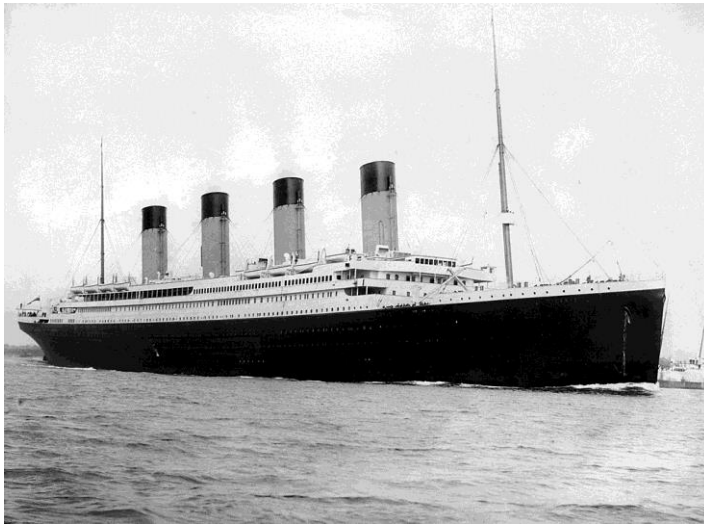

*RMS Titanic departing Southampton on April 10, 1912.*

RMS Titanic was the largest ship afloat at the time she entered service and was the second of three Olympic-class ocean liners operated by the White Star Line. She had a length of 269.1m, a beam of 28.2m, her draught was 10.5m, her gross tonnage was 46,328, she had a speed of 21 knots with a maximum recorded speed of 23 knots and she could accommodate 2,435 passengers and 892 crewmembers.

Titanic was under the command of Captain Edward Smith, who also went down with the ship. The ocean liner carried some of the wealthiest people in the world, as well as hundreds of emigrants from Great Britain and Ireland, Scandinavia and elsewhere throughout Europe, who were seeking a new life in the United States. The first-class accommodation was designed to be the pinnacle of comfort and luxury, with a gymnasium, swimming pool, libraries, high-class restaurants, and opulent cabins.

Her installed power was 24 double-ended and five single-ended boilers feeding two reciprocating steam engines for the wing propellers, and a low-pressure turbine for the center propeller; output: 46,000 HP. She had two three-bladed wing propellers and one four-bladed center propeller.

The wreck of the Titanic was discovered in 1985 (73 years after the disaster) during a Franco-American expedition and United States Military mission. The ship was split in two and is gradually disintegrating at a depth of 12,415 feet (3,784 m). Thousands of artifacts have been recovered and displayed at museums around the world.

---

**SS Imperator** was a German ocean liner built for the Hamburg America Line (Hamburg Amerikanische Paketfahrt Aktien Gesellschaft, or HAPAG), launched in 1912.

At the time of her completion in June 1913, she was the largest passenger ship in the world by gross tonnage, surpassing the new White Star giants, Olympic and Titanic.

She had a length of 276m, a beam of 29.95m, a draught of 10.72m and her gross tonnage was 52,117. She had a maximum recorded speed of 24 knots and she could accommodate 4,234 passengers and 1,180 crewmembers.

During World War I, the ship remained in port in Hamburg. After the war, she was briefly commissioned into the United States Navy as USS Imperator (ID-4080) and employed as a transport, returning American troops from Europe. Following her service with the U.S. Navy, Imperator was handed over to Britain's Cunard Line as part of war reparations where she sailed as the flagship RMS Berengaria for the final decade of her career.

Her propulsion was achieved by 4 steam turbines AEG-Vulcan / Parsons with direct drive on four shafts with a total 60,000 hp (45,000 kW).

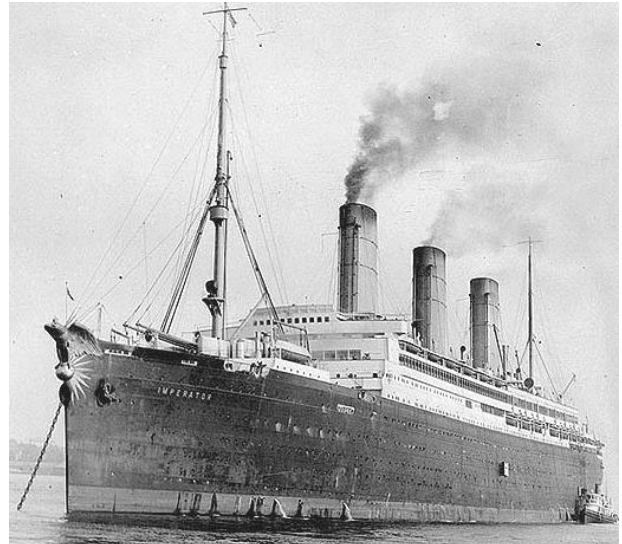

*SS Imperator at anchor, with the grandiose bow eagle of the Hapag company still in place, 1913*



*SS Imperator's damaged Eagle*

The **SS Normandie** was a French ocean liner built in Saint-Nazaire, France, for the French Line Compagnie Générale Transatlantique (CGT). She entered service in 1935 as the largest and fastest passenger ship afloat, crossing the Atlantic in a record 4.14 days. She remains the most powerful steam turbo-electric-propelled passenger ship ever built.

Her means of propulsion was four turbo-electric, total 160,000 hp (200,000 hp max), her propeller was 3 bladed on launch - later 4 bladed.

During her service as the flagship of the CGT, she made 139 westbound transatlantic crossings from her home port of Le Havre to New York. Normandie held the Blue Riband for the fastest transatlantic crossing at several points during her service career, during which the RMS Queen Mary was her main rival.

---

She had a length of 313.6m, a beam of 35.9m, her draught was 11.2m, gross tonnage was 79,280, she had a maximum recorded speed of 32.2 knots and she could accommodate 1,972 passengers and 1,345 crewmembers.



*Colorized picture of the SS Normandie, 1936*

During World War II, Normandie was seized by U.S. authorities at New York and renamed USS Lafayette. In 1942, the liner caught fire while being converted to a troopship, capsized onto her port side and came to rest on the mud of the Hudson River at Pier 88, the site of the current New York Passenger Ship Terminal. Although salvaged at great expense, restoration was deemed too costly and she was scrapped in October 1946.

The **RMS Queen Mary** is a retired British ocean liner that sailed primarily on the North Atlantic Ocean from 1936 to 1967 for the Cunard-White Star Line and built by John Brown & Company in Clydebank, Scotland. Queen Mary, along with RMS Queen Elizabeth, were built as part of Cunard's planned two-ship weekly express service between Southampton, Cherbourg and New York. The two ships were a British response to the express superliners built by German, Italian and French companies in the late 1920s and early 1930s.

Queen Mary sailed on her maiden voyage on 27 May 1936 and won the Blue Riband that August; she lost the title to SS Normandie in 1937 and recaptured it in 1938, holding it until 1952 when it was taken by the new SS United States. With the outbreak of the Second World War, she was converted into a troopship and ferried Allied soldiers during the conflict.



*RMS Queen Mary in Long Beach, California*

She had a length of 310.7m, a beam of 36m, her draught was 11.8m. Her gross tonnage was 80,774, she had a maximum recorded speed of 32.84 knots and she could accommodate 2,139 passengers and 1,101 crewmembers. Her means of propulsion were 4 Parsons single-reduction geared steam turbines amounting to 200,000 hp (150,000 kW).

Following the war, Queen Mary was refitted for passenger service and along with Queen Elizabeth commenced the two-ship transatlantic passenger service for which the two ships were initially built.

The two ships dominated the transatlantic passenger transportation market until the dawn of the jet age in the late 1950s. By the mid-1960s, Queen Mary was ageing and was operating at a loss.

---

The **RMS Queen Elizabeth** was an ocean liner operated by Cunard Line. With Queen Mary she provided weekly luxury liner service between Southampton in the United Kingdom and New York City in the United States, via Cherbourg in France.

She had a length of 314.2m, a beam of 36m, her draught was 11.8m. Her gross tonnage was 83,673, she had a service speed of 28.5 knots and she could accommodate 2,139 passengers and 1,101 crewmembers. Her means of propulsion were 4 Parsons single-reduction geared steam turbines amounting to 200,000 hp (150,000 kW).

While being constructed in the mid-1930s by John Brown & Company at Clydebank, Scotland, the build was known as Hull 552. She was launched on 27 September 1938 and named in honor of Queen Elizabeth.

With a design that improved upon that of Queen Mary, Queen Elizabeth was a slightly larger ship, the largest passenger liner ever built at that time and for 56 years thereafter. She also has the distinction of being the largest-ever riveted ship by gross tonnage. She first entered service in February 1940 as a troopship in the Second World War, and it was not until October 1946 that she served in her intended role as an ocean liner.



*RMS Queen Elizabeth at Cherbourg, France, 1966*

In 1972, whilst she was undergoing refurbishment in Hong Kong harbor, fire broke out aboard under unexplained circumstances, and the ship was capsized by the water used to fight the fire.

**SS United States** is a retired ocean liner built in 1950–51 for the United States Lines at a cost of \$79.4 million. The ship is the largest ocean liner constructed entirely in the United States and the fastest ocean liner to cross the Atlantic in either direction, retaining the Blue Riband for the highest average speed since her maiden voyage in 1952.

She was designed by American naval architect William Francis Gibbs and could be converted into a troopship if required by the Navy in time of war. The United States maintained an uninterrupted schedule of transatlantic passenger service until 1969 and was never used as a troopship.



*SS United States docked at pier 82 in Philadelphia, August 2020*

---

She has a length of 314.2m, a beam of 36m, her draught is 11.8m. Her gross tonnage is 83,673, she has a service speed of 35 knots (65km/h) and a claimed speed of 43 knots (80km/h), she can accommodate 1,928 passengers and 900 crewmembers. Her means of propulsion is 4 × Westinghouse double-reduction geared steam turbines that deliver a power of 240,000 shaft horsepower (180 MW) to four 18-foot (5.5 m)-diameter manganese-bronze propellers.

The ship has been sold several times since the 1970s, with each new owner trying unsuccessfully to make the liner profitable. Eventually, the ship's fittings were sold at auction, and hazardous wastes, including asbestos panels throughout the ship, were removed, leaving her almost completely stripped by 1994. Two years later, she was towed to Pier 82 on the Delaware River, in Philadelphia, where she remains today.

**Liberty ships** were a class of cargo ships built in the United States during World War II. Though British in concept, the design was adopted by the United States for its simple, low-cost construction. Mass-produced on an unprecedented scale, the Liberty ship came to symbolize U.S. wartime industrial output.

The liberties had a length of 134.57m, a beam of 17.3m, a draft of 8.5m, a speed of 11-11.5 knots and a displacement of 14,474 tons.



*SS John W. Brown, one of the four surviving Liberty ships, photographed in 2000*

The class was developed to meet British orders for transports to replace ships that had been lost. Eighteen American shipyards built 2,710 Liberty ships between 1941 and 1945 (an average of three ships every two days), easily the largest number of ships ever produced to a single design.

By 1941, the steam turbine was the preferred marine steam engine because of its greater efficiency compared to earlier reciprocating compound steam engines. Steam turbine engines required very precise manufacturing techniques and balancing and a complicated reduction gear, however, and the companies capable of manufacturing them already were committed to the large construction program for warships.

Therefore, a 140-ton vertical triple expansion steam engine of obsolete design was selected to power Liberty ships because it was cheaper and easier to build in the numbers required for the Liberty ship program and because more companies could manufacture it. It had the additional advantage of ruggedness and simplicity. Parts manufactured by one company were interchangeable with those made by another, and the openness of its design made most of its moving parts easy to see, access, and oil.

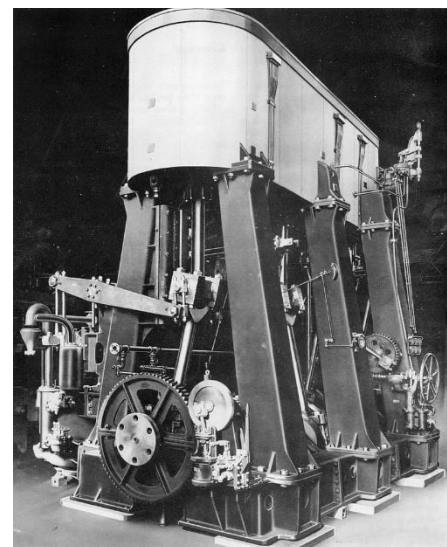

*Vertical triple expansion steam engine used in Liberty ships*

---

## 5.27 – Decline of the Steamship

The decline of the steamship began after World War II (1939-1945). Many had been lost in the war, and marine diesel engines had finally matured as an economical and viable alternative to steam power. The diesel engine had far better thermal efficiency than the reciprocating steam engine, and was far easier to control. Diesel engines also required far less supervision and maintenance than steam engines and as an internal combustion engine it did not need boilers or a water supply and therefore was more space efficient.

The Liberty ships were the last major steamship class equipped with reciprocating engines. Most steamers were used up to their maximum economical life span, and no commercial ocean-going steamers with reciprocating engines have been built since the 1960s.

Most steamships today are powered by steam turbines. While steam turbine-driven merchant ships such as the Algol-class cargo ships (1972–1973), ALP Pacesetter-class container ships (1973–1974) and very large crude carriers were built until the 1970s, the use of steam for marine propulsion in the commercial market has declined dramatically due to the development of more efficient diesel engines.

However, the development of dual-fuel engines has pushed steam turbines into a niche market with about 10% market share in new buildings in 2013. Lately, there has been some development in hybrid power plants where the steam turbine is used together with gas engines. As of August 2017 the newest class of Steam Turbine ships are the Seri Camellia-class LNG carriers built by Hyundai Heavy Industries (HHI) starting in 2016 and comprising of five units.

---

## CHAPTER 6 – THE INTERNAL COMBUSTION ENGINE

It is not the intention of this chapter to engage in historical debate of who invented the diesel engine, therefore the discussion will mainly be based on the operating principals and design criteria that were employed in the initial designs of the compression engines. The birth of a compression engine could be attributed to the Lenoir cycle where it first used a mixture of air - vapor and oil - in a gas engine. The creator was Étienne Lenoir a Belgian inventor who devised the first commercially successful internal-combustion engine.

### 6.1 – Lenoir Cycle 1860 (The Gas Engine)

First, air gas mixture was drawn into the cylinder on suction stroke for about one third of the travel. When the inlet valve closed, the mixture was then exploded by making contact with an open flame. The burning mixture would expand and force down the piston, down the remaining two thirds of the stroke, thus forming the power stroke.

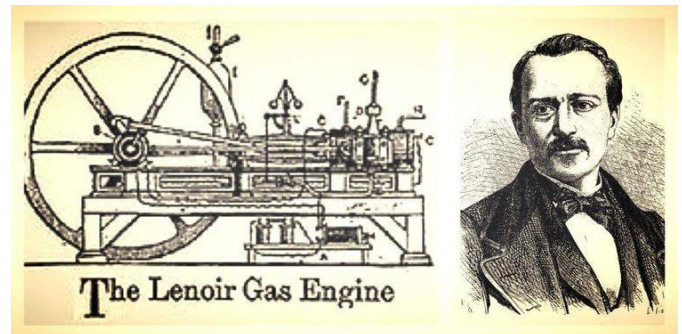

*The Lenoir Gas Engine*

**Drawbacks of this engine were:**

1. Lower engine speed (rpm) resulting in low power being produced. Therefore, it could not compete with the steam engines.
2. Lack of fuel sources as it required gas, coal or oil products for its fuel.
3. Hazardous, as ignition had to be done from an open flame.

Lenoir's engine was a converted double-acting steam engine with slide valves to admit the air-fuel mixture and to discharge exhaust products. As a two-stroke cycle engine, it used a mixture of coal gas and air. Though only about 4 percent efficient in fuel consumption, it was a smooth-running and durable machine (some machines were in perfect condition after 20 years of continuous operation), and by 1865 more than 400 were in use in France and 1,000 in Britain. They were used for low-power jobs such as pumping and printing.

In 1862 Lenoir built the first automobile with an internal-combustion engine. He had adapted his engine to run on liquid fuel and with his vehicle made a 6-mile (10-kilometre) trip that required two to three hours. He also invented a motorboat using his engine (1886).

The arrival of a petroleum distillate on the market in 1873, enabled it to be used in a gas engine, suitably vaporized by drawing air over a surface of petrol, and the gas engine thus became a self-contained oil - vapor engine. Daimler Benz in 1883 developed the petrol motor engine which was less hazardous and is now successful in the motor industry. The engine could turn up to 800 rpm which was an improvement from the previous 200 rpm. Other scientists, like Kjelsberg 1889, Akroyd - Stuart 1890 further worked on the idea and also improved the design to incorporate the low-compression engines where the fuel was injected into a hot un-cooled chamber through a needle valve by a jerk pump. From here on, most of the developments being done would lead to the compression engine.

---

## 6.2 – Dr. Rudolf Diesel

In 1878, Rudolf Diesel, who was a student at the "Polytechnikum" in Munich, attended the lectures of Carl von Linde. Linde explained that steam engines are capable of converting just 6–10% of the heat energy into work, but that the Carnot cycle allows conversion of much more of the heat energy into work by means of isothermal change in condition. According to Diesel, this ignited the idea of creating a highly efficient engine that could work on the Carnot cycle. The Carnot cycle provides an upper limit on the efficiency that any classical thermodynamic engine can achieve during the conversion of heat into work.

After several years of working on his ideas, Diesel published them, in 1893, in the essay *Theory and Construction of a Rational Heat Motor*. Diesel was heavily criticised for his essay, but only few found the mistake that he made; his rational heat motor was supposed to utilise a constant temperature cycle (with isothermal compression) that would require a much higher level of compression than that needed for compression ignition.



*Dr. Rudolf Diesel*

Diesel's initial idea was to compress the air so tightly that the temperature of the air would exceed that of combustion. However, such an engine could never perform any usable work. In his 1892 US patent (granted in 1895) #542846 Diesel describes the compression required for his cycle.

By June 1893, Diesel had realised his original cycle would not work and he adopted the constant pressure cycle. Diesel describes the cycle in his US patent # 608845 filed 1895 / granted 1898. There is no longer a mention of compression temperatures exceeding the temperature of combustion. Now it is simply stated that the compression must be sufficient to trigger ignition.

Diesel was attacked and criticised over a time period of several years. Critics have claimed that Diesel never invented a new motor and that the invention of the diesel engine is fraud. Köhler had published an essay in 1887, in which he describes an engine similar to the engine Diesel describes in his 1893 essay. Köhler figured that such an engine could not perform any work. Emil Capitaine had built a petroleum engine with glow-tube ignition in the early 1890s; he claimed against his own better judgement, that his glow-tube ignition engine worked the same way Diesel's engine did. His claims were unfounded and he lost a patent lawsuit against Diesel. Other engines, such as the Akroyd engine and the Brayton engine, also use an operating cycle that is different from the diesel engine cycle. Friedrich Sass says that the diesel engine is Diesel's "very own work" and that any "Diesel myth" is "falsification of history".



## 6.3 – The First Diesel Engine

Diesel sought out firms and factories that would build his engine. With the help of Moritz Schröter and Max Gutermuth, he succeeded in convincing both Krupp in Essen and the Maschinenfabrik Augsburg. Contracts were signed in April 1893, and in early summer 1893. Diesel's first prototype engine was built in Augsburg. On 10 August 1893 the first ignition took place, the fuel used was petrol.

In winter 1893/1894, Diesel redesigned the existing engine, and by 18 January 1894, his mechanics had converted it into the second prototype. On February 17, 1894, the redesigned engine ran for 88 revolutions – one minute; with this news, Maschinenfabrik Augsburg's stock rose by 30%, indicative of the tremendous anticipated demands for a more efficient engine. On 26 June 1895 the engine achieved an effective efficiency of 16.6% and had a fuel consumption of  $519 \text{ g}\cdot\text{kW}^{-1}\cdot\text{h}^{-1}$ . However, despite proving the concept, the engine caused problems and Diesel could not achieve any substantial progress. Therefore, Krupp considered rescinding the contract they had made with Diesel.

Diesel was forced to improve the design of his engine and rushed to construct a third prototype engine. Between 8 November and 20 December 1895, the second prototype had successfully covered over 111 hours on the test bench. In the January 1896 report, this was considered a success.

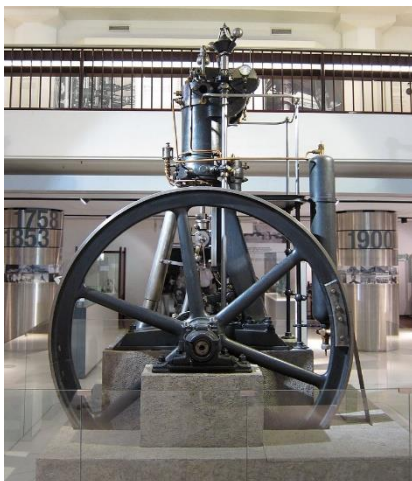

*First fully functional diesel engine, designed by Imanuel Lauster, built from scratch, and finished by October 1896*

In February 1896, Diesel considered supercharging the third prototype. Imanuel Lauster, who was ordered to draw the third prototype, had finished the drawings by 30 April 1896. During summer that year the engine was built, it was completed on 6 October 1896. Tests were conducted until early 1897. First public tests began on 1 February 1897. Moritz Schröter's test on 17 February 1897 was the main test of Diesel's engine. The engine was rated 13.1 kW with a specific fuel consumption of  $324 \text{ g}\cdot\text{kW}^{-1}\cdot\text{h}^{-1}$ , resulting in an effective efficiency of 26.2%. By 1898, Diesel had become a millionaire.

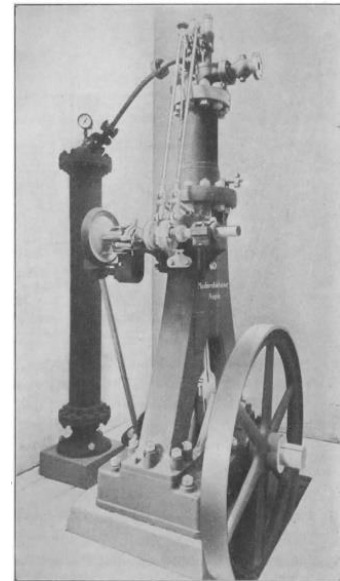

*Diesel's first experimental engine  
1893*



*Diesel's second prototype. It is a modification of the first experimental engine. On 17 February 1894, this engine ran under its own power for the first time*

## 6.4 – The First Two Stroke Diesel Engine

According to the designer of the first operational Diesel engine, Imanuel Lauster, Diesel never intended using the two-stroke principle for the Diesel engine. It is believed, that Hugo Güldner invented the two-stroke Diesel engine. He designed the first operational two-stroke Diesel engine in 1899, and he convinced MAN, Krupp and Diesel to fund building this engine. Güldner's engine had a 175 mm work cylinder, and a 185 mm scavenging cylinder; both had a stroke of 210 mm. The indicated power output was 12 hp (8826 W). In February 1900, this engine ran under its own power for the first time. However, with its actual power output of only 6.95 hp (5112 W) and high fuel consumption of  $380 \text{ g}\cdot\text{hp}^{-1}\cdot\text{h}^{-1}$  ( $517 \text{ g}\cdot\text{kW}^{-1}\cdot\text{h}^{-1}$ ), it did not prove to be successful. Güldner's two-stroke Diesel engine project was abandoned in 1901.

In 1908, MAN Nürnberg offered single-acting piston two-stroke Diesel engines for marine use, the first double-acting piston engine from MAN Nürnberg was made in 1912 for an electric power plant. In collaboration with Blohm + Voss in Hamburg, MAN Nürnberg built the first double-acting piston two-stroke engine for marine use in 1913/1914. During World War I, MAN Nürnberg built a six-cylinder, double-acting piston, two-stroke Diesel engine with a rated power of 12,400 hp (9120 kW).

## 6.5 - Diesel Engines Classified by Number of strokes

A **two-stroke** (or two-cycle) **engine** is a type of internal combustion engine that completes a power cycle with two strokes (up and down movements) of the piston during only one crankshaft revolution.

This is in contrast to a "four-stroke engine", which requires four strokes of the piston to complete a power cycle during two crankshaft revolutions.

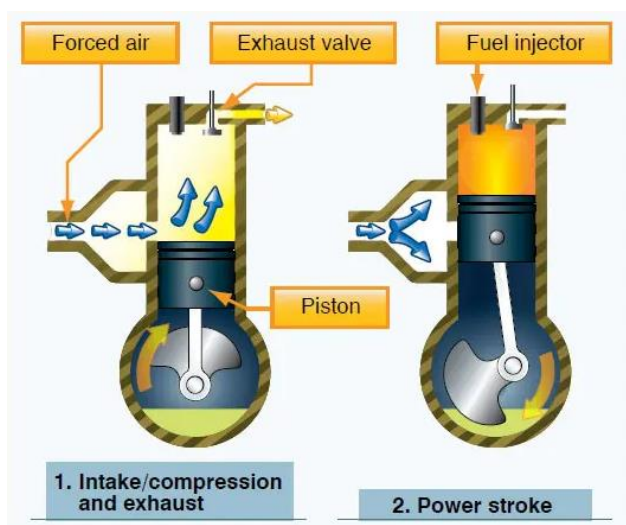
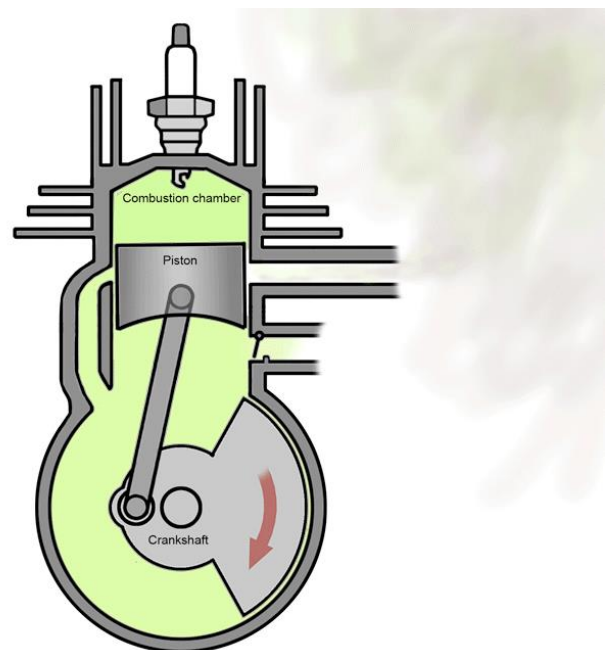

Diagram of the Two-Stroke Engine Cycle



Animation of a Two-Stroke Diesel Engine

In a two-stroke engine, the end of the combustion stroke and the beginning of the compression stroke happen simultaneously, with the intake and exhaust (or scavenging) functions occurring at the same time.

A **four-stroke** (also four-cycle) **engine** is an internal combustion (IC) engine in which the piston completes four separate strokes while turning the crankshaft. A stroke refers to the full travel of the piston along the cylinder, in either direction. The four separate strokes are termed:

**1. Intake:** Also known as induction or suction. This stroke of the piston begins at top dead center (T.D.C.) and ends at bottom dead center (B.D.C.). In this stroke the intake valve must be in the open position while the piston pulls an air-fuel mixture into the cylinder by producing vacuum pressure into the cylinder through its downward motion. The piston is moving down as air is being sucked in by the downward motion against the piston.

**2. Compression:** This stroke begins at B.D.C, or just at the end of the suction stroke, and ends at T.D.C. In this stroke the piston compresses the air-fuel mixture in preparation for ignition during the power stroke (below). Both the intake and exhaust valves are closed during this stage.

**3. Combustion:** Also known as power or ignition. This is the start of the second revolution of the four-stroke cycle. At this point the crankshaft has completed a full 360-degree revolution. While the piston is at T.D.C. (the end of the compression stroke) the compressed air-fuel mixture is ignited by a spark plug (in a gasoline engine) or by heat generated by high compression (diesel engines), forcefully returning the piston to B.D.C. This stroke produces mechanical work from the engine to turn the crankshaft.

**4. Exhaust:** Also known as outlet. During the exhaust stroke, the piston, once again, returns from B.D.C. to T.D.C. while the exhaust valve is open. This action expels the spent air-fuel mixture through the exhaust valve.

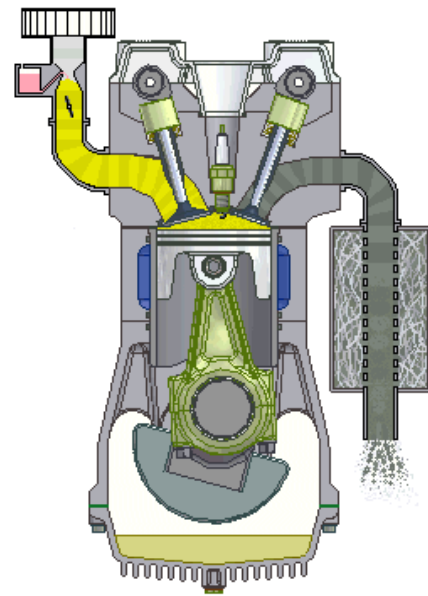

*Animation of The Four-Stroke Diesel Engine*

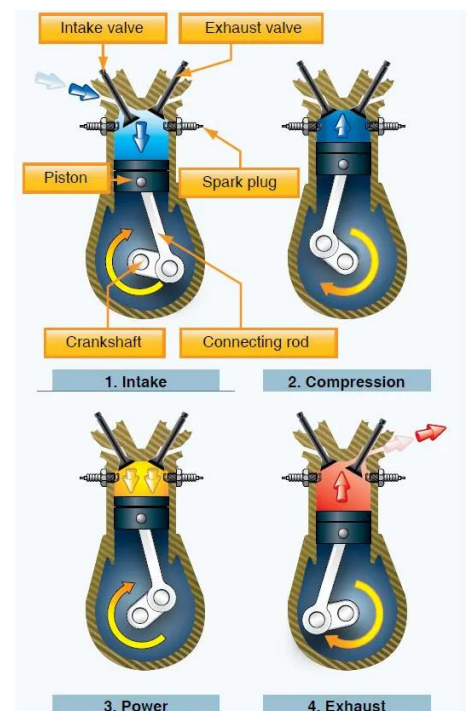

*Diagram of the Four-Stroke Engine Cycle*

---

## 6.6 - Diesel Engines Classified by Engine Speeds

**Low-speed diesel engines**, are characterized by rated speeds in the range of 80–120 revolutions per minute, are usually very large in size and mostly used to power ships. There are two different types of low-speed engines that are commonly used: Two-stroke engines with a crosshead, and four-stroke engines with a regular trunk-piston.

Two-stroke engines have a limited rotational frequency and their charge exchange is more difficult, which means that they are usually bigger than four-stroke engines and used to directly power a ship's propeller. Four-stroke engines on ships are usually used to power an electric generator.

The consequence of low speed is a longer piston stroke and greater cylinder bore, albeit with fewer cylinders; the net result is a heavier engine, with a specific weight (weight per unit of output) of about 40 kg (88 pounds) per kilowatt—in contrast to a typical figure of 20 kg (44 pounds) per kilowatt of a medium-speed engine.

Nevertheless, low speed and large individual cylinder displacement convey advantage to the low-speed engine, since these features allow the lowest-quality—and hence cheapest—fuel to be burned. Even finely powdered coal and coal-oil slurries have been burned in these engines on an experimental basis.

Height, in particular, is a limiting feature of the low-speed engine. In some types of ships, the extra machinery space will interfere with cargo or passenger space.

Along with these engines an electric motor powers the propeller. Low-speed diesel engines (as used in ships and other applications where overall engine weight is relatively unimportant) often have an effective efficiency of up to 55%. Like medium-speed engines, low-speed engines are started with compressed air, and they use heavy oil as their primary fuel.

**Medium-speed engines**, characterized by rated speeds in the range of 400–600 revolutions per minute and are used in large electrical generators, ship propulsion and mechanical drive applications such as large compressors or pumps. Medium speed diesel engines operate on either diesel fuel or heavy fuel oil by direct injection in the same manner as low-speed engines. Usually, they are four-stroke engines with trunk pistons.

The power output of medium-speed diesel engines can be as high as 21,870 kW, with the effective efficiency being around 47...48% (1982). Larger medium-speed engines are started with compressed air directly the on pistons, using an air distributor, as opposed to a pneumatic starting motor acting on the flywheel, which tends to be used for smaller engines.

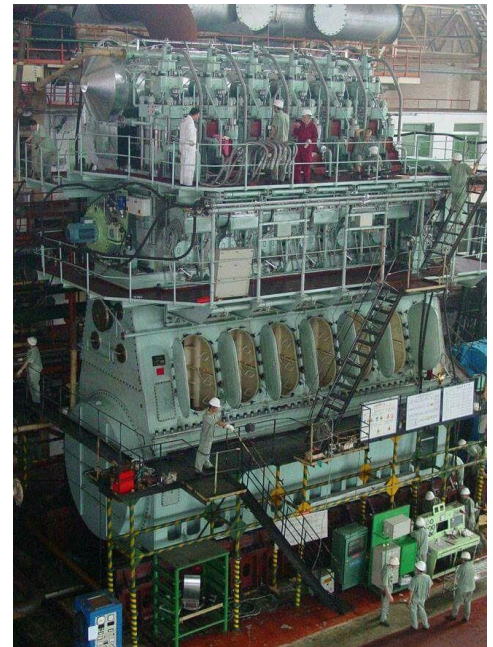

*Marine Diesel Low Speed Two-Stroke Engine*

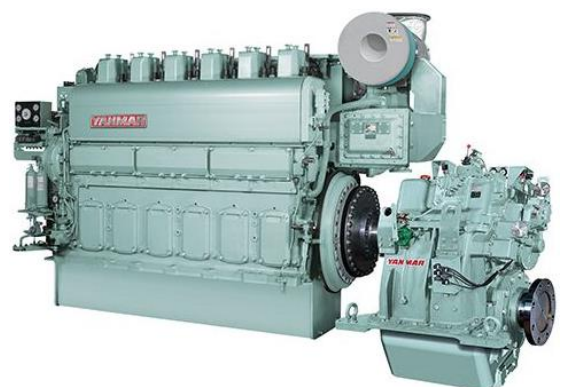

*Medium Speed Four-Stroke Diesel Engine*

---

Medium-speed engines are favoured where a particularly heavy or tall engine would be inappropriate and where a lower first cost would outweigh the higher fuel cost. On the other hand, its higher speed nearly always demands a speed-reducing gear between the engine and propeller—a component that is usually unnecessary with low-speed engines. Other handicaps of the medium-speed alternative are a greater number of cylinders for a given power rating and a specific fuel rate (weight of fuel burned per unit of output) that is typically higher than with low-speed engines.

Medium-speed engines intended for marine applications are usually used to power (ro-ro) ferries, passenger ships or small freight ships. Using medium-speed engines reduces the cost of smaller ships and increases their transport capacity. In addition to that, a single ship can use two smaller engines instead of one big engine, which increases the ship's safety.

**High-speed engines**, with rated speeds of 900 to 1,200 revolutions per minute, these are used to power trucks (lorries), buses, tractors, cars, yachts, tugs, fishing vessels, high-speed ferries, compressors, pumps and small electrical generators. As of 2018, most high-speed engines have direct injection.

On bigger ships, high-speed diesel engines are often used for powering electric generators. The highest power output of high-speed diesel engines is approximately 5 MW.

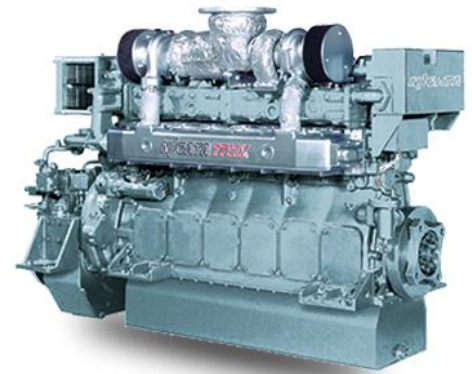

*High Speed Diesel Engine*

## 6.7 - Diesel Engines Classified by Cylinder Arrangement

### Opposed-piston engine

An opposed-piston engine is a piston engine in which each cylinder has a piston at both ends, and no cylinder head. Petrol and diesel opposed-piston engines have been used mostly in large-scale applications such as ships, military tanks, and factories. The first diesel engine with opposed pistons was a prototype built at Kolomna Works in Russia. The designer, Raymond A. Koreyvo, patented the engine in France on 6 November 1907 and displayed the engine at international exhibitions, but it did not reach production. The Kolomna design used a typical layout of two crankshafts connected by gearing.

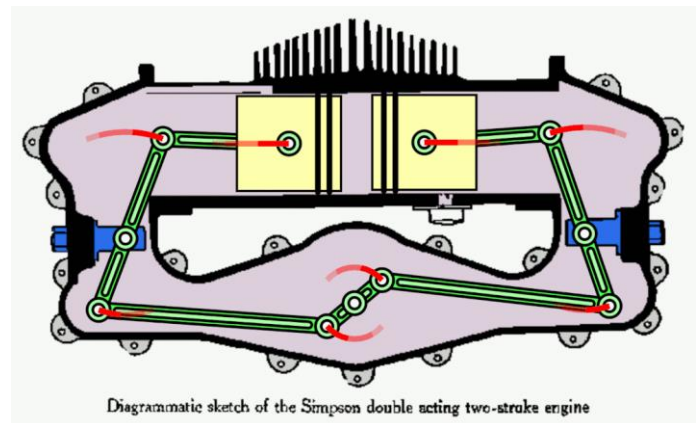

Diagrammatic sketch of the Simpson double acting two-stroke engine

*Opposed-piston engine animation*

---

## Inline Engine

The straight or inline engine is an internal combustion engine with all cylinders aligned in one row and having no offset. Usually found in four-, six- and eight-cylinder configurations, they have been used in automobiles, locomotives, aircraft and ship propulsion.

A straight engine is considerably easier to build than an otherwise equivalent horizontally opposed or V engine, because both the cylinder bank and crankshaft can be milled from a single metal casting, and it requires fewer cylinder heads and camshafts. In-line engines are also smaller in overall physical dimensions than designs such as the radial, and can be mounted in any direction.

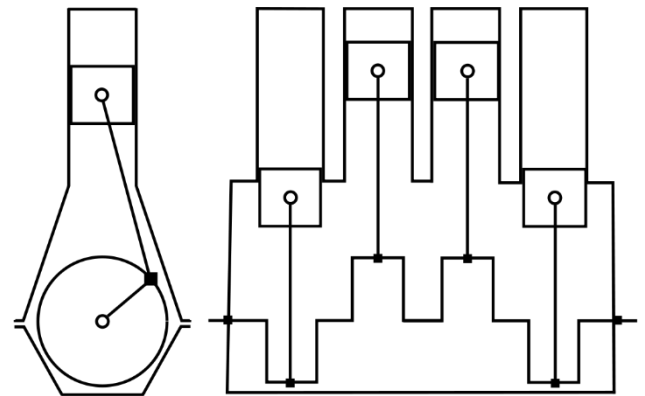

*4-Cylinder Straight Engine Scheme*

## V Engine

A V engine, sometimes called a Vee engine, is a common configuration for internal combustion engines. It consists of two-cylinder banks — usually with the same number of cylinders in each bank — connected to a common crankshaft.

These cylinder banks are arranged at an angle to each other, so that the banks form a "V" shape when viewed from the front of the engine.

V engines typically have a shorter length than equivalent inline engines, however the trade-off is a larger width. V6, V8 and V12 engines are the most common layout for automobile engines with six, eight or twelve cylinders respectively.

The first V engine, a two-cylinder V-twin, was designed by Wilhelm Maybach and used in the 1889 Daimler Stahlradwagen automobile.

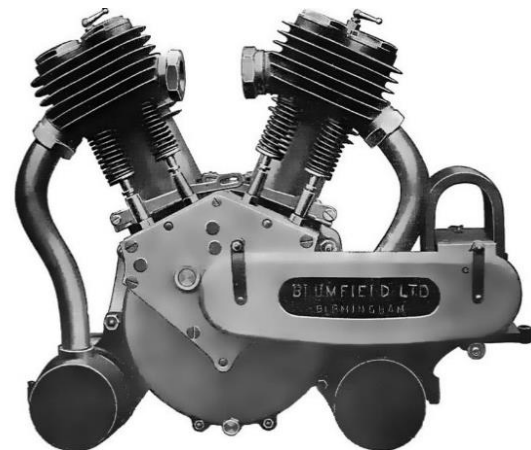

*V-Twin motorcycle Engine*



*V6 Car Engine*

## W Engine

A W engine is a type of piston engine where three- or four-cylinder banks use the same crankshaft, resembling the letter W when viewed from the front. W engines with three banks of cylinders are also called "broad arrow" engines, due to their shape resembling the British government broad arrow property mark.

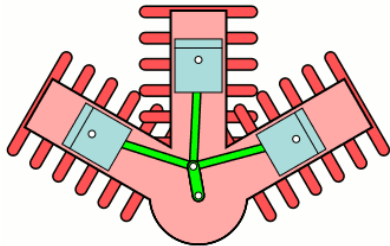

*Operation of a W Engine*



*Napier Lion W12 aircraft Engine, 1930*

W engines are less common than V engines. Compared with a V engine, a W engine is typically shorter and wider. One of the first W engines was the Anzani 3-cylinder, built in 1906, to be used in Anzani motorcycles.

## Radial Engine

The radial engine is a reciprocating type internal combustion engine configuration in which the cylinders "radiate" outward from a central crankcase like the spokes of a wheel. It resembles a stylized star when viewed from the front, and is also called "star engine". The pistons are connected to the crankshaft with a master-and-articulating-rod assembly.

One piston, the uppermost one in the picture, has a master rod with a direct attachment to the crankshaft. The remaining pistons pin their connecting rods' attachments to rings around the edge of the master rod.

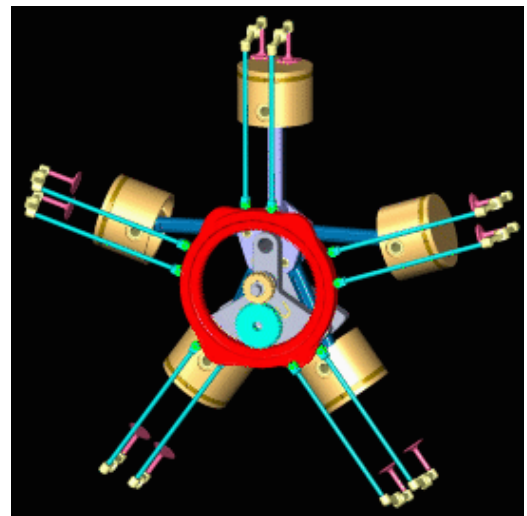

*Radial Engine Animation*



*Radial Engine of a biplane*

Extra "rows" of radial cylinders can be added in order to increase the capacity of the engine without adding to its diameter.

Although they have been used mostly in race cars, aircrafts and tanks. Electro-Motive Diesel (EMD) built the "pancake" engines 16-184 and 16-338 for marine use.

## Rotary Engine

The rotary engine was an early type of internal combustion engine, usually designed with an odd number of cylinders per row in a radial configuration, in which the crankshaft remained stationary in operation, with the entire crankcase and its attached cylinders rotating around it as a unit. Its main application was in aviation, although it also saw use before its primary aviation role, in a few early motorcycles and automobiles.

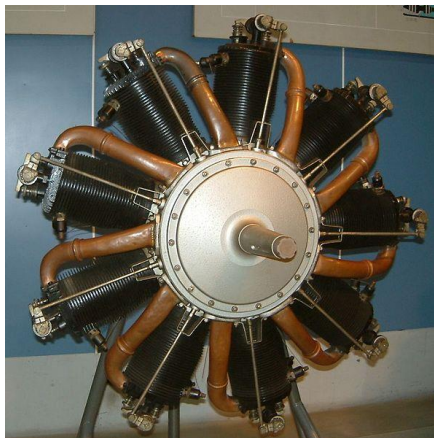

*Typical Rotary Engine of WWI*

It hasn't been used in marine practices other than experimental purposes and it was rendered obsolete by the early 1920s due to the inherent limitations that it had.

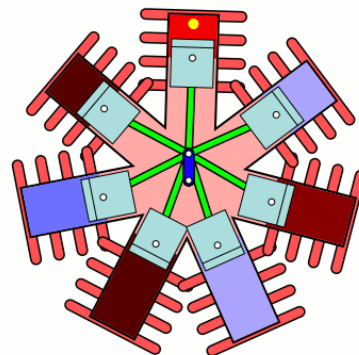

*Animation of a seven-cylinder rotary engine with every-other-piston firing order.*

## Wankel Engine

The Wankel engine is a type of internal combustion engine using an eccentric rotary design to convert pressure into rotating motion.

Compared to the reciprocating piston engine, the Wankel engine has more uniform torque and less vibration and, for a given power, is more compact and weighs less.

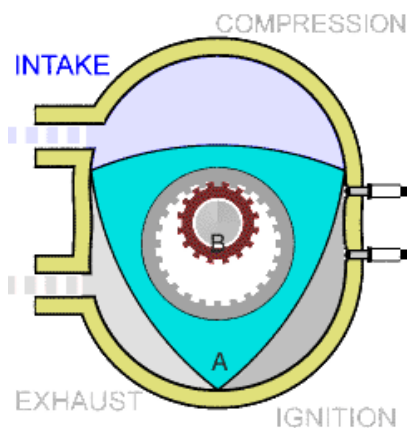

*Animation of the Wankel Rotor Orbital revolution*

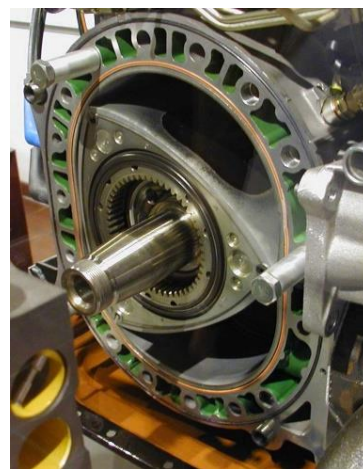

*A Wankel Engine with its rotor and geared output shaft*

These advantages give the rotary engine applications in a variety of vehicles and devices, including automobiles, motorcycles, racing cars, aircraft, go-karts, jet skis, snowmobiles, chainsaws and auxiliary power units. In the Wankel engine, the four strokes of an Otto cycle occur in the space between each face of a three-sided symmetric rotor and the inside of a housing.



---

## 6.8 - Marine Diesel Engine Turbochargers and Superchargers

For efficiently burning diesel fuel in the engines, it is imperative that sufficient air is supplied at every cycle inside the cylinders. To achieve this, a variety of methods were adopted for supplying fresh air to burn the fuel and to produce the required power within all cylinders of the engine.

Before turbocharging came, the process of supercharging process was used. A mechanical arrangement within the engine was used to supply extra air to the combustion chamber of the engines. Below there will be shown some methods and arrangements used to supply fresh charge air.

### Supercharger

A supercharger is an air compressor that increases the pressure or density of air supplied to an internal combustion engine. This gives each intake cycle of the engine more oxygen, letting it burn more fuel and do more work, thus increasing the power output.

Power for the supercharger can be provided mechanically by means of a belt, gear, shaft, or chain connected to the engine's crankshaft. Common usage restricts the term supercharger to mechanically driven units.

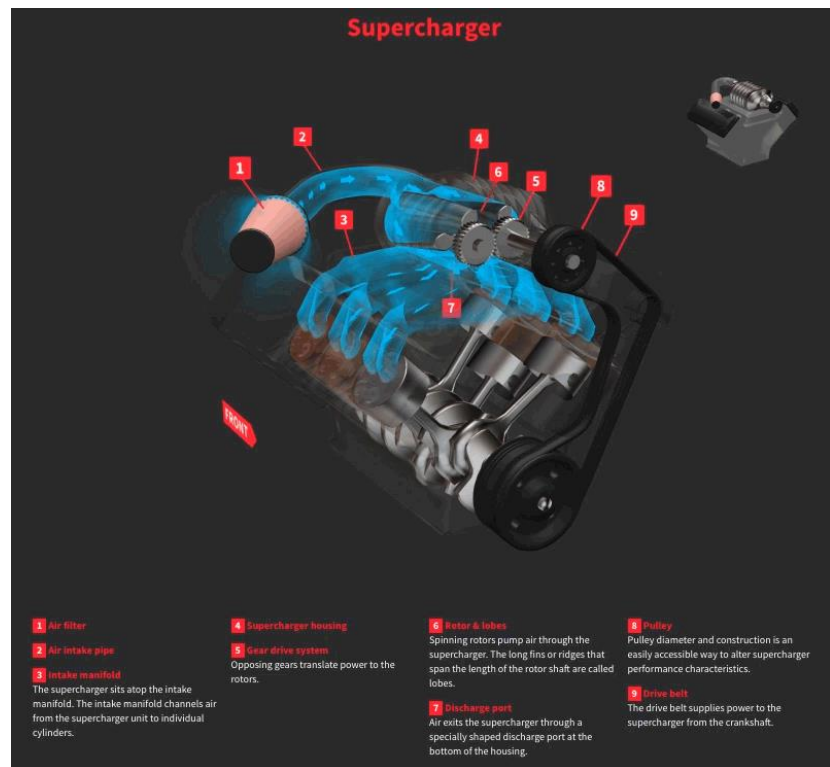

*Animation of a Modern Supercharger used on a Four Stroke Diesel Engine*

There are two main types of superchargers defined according to the method of gas transfer: positive displacement and dynamic compressors.

- **Positive displacement blowers** and compressors deliver an almost constant level of pressure increase at all engine speeds (RPM).
- **Dynamic compressors** do not deliver pressure at low speeds; above a threshold, speed pressure increases exponentially.

---

We are going to examine Positive displacement blowers, because they are the ones that are utilized in marine applications. Dynamic compressors (Centrifugal, Multi-stage axial-flow) don't interest us at this topic as they are used in Automotive, Aircraft, Research and Industrial applications.

**Positive-displacement pumps are divided into internal and external compression types:**

- **External compression** refers to pumps that transfer air at ambient pressure. If an engine equipped with a supercharger that compresses externally and is running under boost conditions, the pressure inside the supercharger remains at ambient pressure; air is only pressurized downstream of the supercharger. Roots superchargers tend to be very mechanically efficient at moving air at low-pressure differentials, whereas at high-pressure ratios, internal compression superchargers tend to be more mechanically efficient.
- **Internal compression** refers to the compression of air within the supercharger itself, which, already at or close to boost level, can be delivered smoothly to the engine with little or no backflow. Internal compression devices usually use a fixed internal compression ratio. When the boost pressure is equal to the compression pressure of the supercharger, the backflow is zero. If the boost pressure exceeds that compression pressure, backflow can still occur as in a roots blower. The internal compression ratio of this type of supercharger can be matched to the expected boost pressure in order to optimize mechanical efficiency.

### Mainstream Types of Superchargers

- The **Roots-type blower** is a positive displacement lobe pump which operates by pumping air with a pair of meshing lobes resembling a set of stretched gears. Air is trapped in pockets surrounding the lobes and carried from the intake side to the exhaust. Roots superchargers produce compression externally.

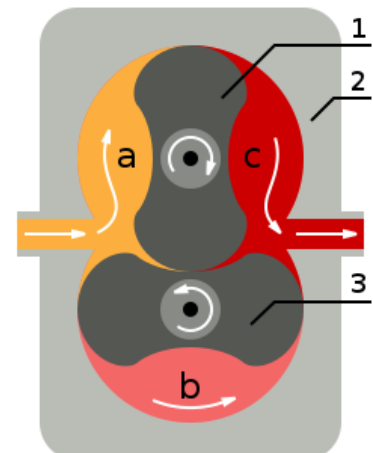

*Roots-Type Blower Diagram*

- **Lysholm screw rotors** with complex shape of each rotor, which must run at high speed and with close tolerances. This makes this type of supercharger expensive. These type or rotors function similarly to the roots type supercharger and also produce compression externally.



*Lysholm screw rotor*

---

## Electric motor driven blower

A diesel engine will draw in as much air as it needs; however, the harder it has to work the less efficiently the engine is working – wasting fuel, limiting rpm, increasing carbon build-up and causing extra engine wear.

Electric motor driven blowers for engines, which are used till now, provide initial charging air during the start of the engine, or when an extra push is needed by automation.

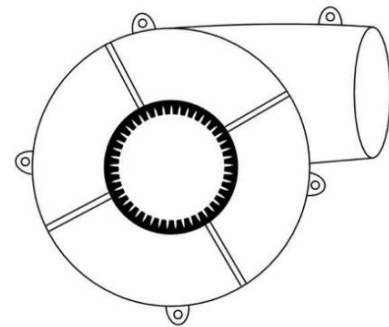

*"Squirrel Cage" Type, Axial Blower*

## Scavenge ports

Scavenge ports provided in the cylinder liners are widely used in old marine engines to charge the combustion chamber with fresh air when piston is in its downward motion.

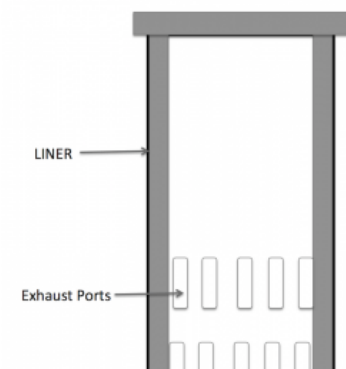

*Scavenge Ports inside combustion Chamber*

## Turbocharger

The Marine Diesel Engine Turbocharger is an integral part of the ship's marine engine as it reuses the exhaust gases in order to increase the overall efficiency of the engine.

The equipment consists of a turbine and a blower attached on the same shaft. The rotation of the turbine side as a result of the exhaust gases flowing over it turns the blower and supplies air to the scavenge side.

Turbocharger converts the waste energy of exhaust gas into useful work by supercharging the combustion process, and hence it is important to maintain the machinery.

As a marine engineer working on ships, you would be required to monitor the performance of turbochargers during the watch and carry out maintenance whenever required.

Two-stroke engine turbocharging is achieved by two distinct methods, respectively termed as the 'constant pressure' and 'pulse' systems. It is the constant pressure system that is now used by all low speed two- stroke engines.

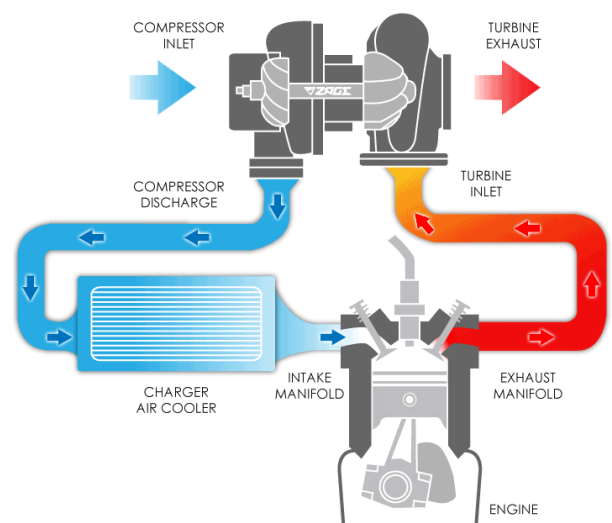

*Animation of the operation of a Turbocharger*

## Constant Pressure Turbocharging System

Exhaust gas from all cylinders is directed into a common large manifold. The gas flow will be steady rather than intermittent and at a constant pressure at the turbine inlet. There is no exhaust grouping, firing order is not considered.

### Advantages of the constant pressure system:

1. Good performance under high loads.
2. More suitable for high output engines.
3. There is no need to group the cylinders exhaust into multiple of three (simple piping system).
4. High turbine efficiency due to steady flow of exhaust.
5. The work transfer at the turbine wheel is smooth.
6. Reduction in SFOC (Specific Fuel Oil Consumption) of 5% – 7%

### Disadvantages of the constant pressure system:

1. When running at reduced speeds and starting up there is low available energy at the turbine. Thus, it supplies inadequate air quantity which is necessary for efficient scavenging and combustion.
2. It requires scavenge assistance (auxiliary Blowers).
3. Poor response in changing load.

## Pulse Turbocharging System

Makes full use of the higher pressure and temperature of the exhaust gas during the blow down period. While rapidly opening the exhaust valves, exhaust gas leaves the cylinder at high velocity as pressure energy is converted into kinetic energy to create the pressure wave or pulse in the exhaust. These pressure waves or pulses are led directly to the turbocharger.

The Exhaust pipe, constructed small in diameter, is quickly pressurized and boosted up to form a pressure pulse or wave. Pressure waves reach the turbine nozzles and further expansion takes place.

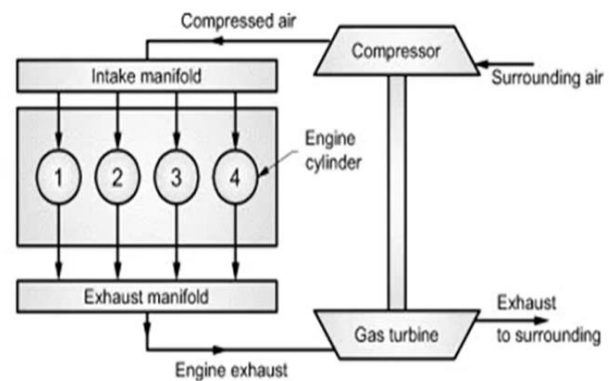

Diagram of a Constant Pressure Turbocharging System

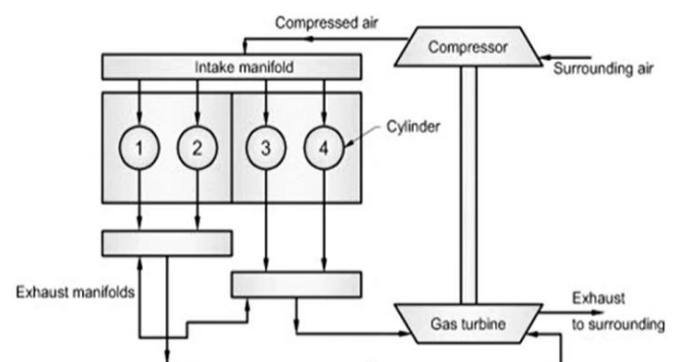

Diagram of a Pulse Turbocharging System

---

Interference exists between exhausting and scavenging among cylinders, to prevent this, cylinders are grouped relatively with connections of two or more exhaust pipes. The pipes have a small diameter to boost up pressure and also are designed straight to prevent energy loss. The number of exhaust branches depends upon the firing order, number of cylinders and the turbocharger design.

#### **Advantages of the pulse system:**

1. At low loads and low speeds, it is more efficient.
2. No need of assistant from a scavenge pump or a blower at any load change.
3. It is highly responsive to changes in the engine condition resulting in good performance at any given speed of the engine.
4. High available energy at the turbine.
5. Good turbocharger acceleration.

#### **Disadvantages of the pulse system:**

1. The exhaust grouping is complicated.
2. Different sizes of exhaust pipes are needed for spare.
3. High pressure exhaust from one cylinder would pass back into another cylinder during the low-pressure scavenging period, thus adversely affecting the combustion efficiency.

#### **Scavenge air coolers**

With the increase in demand of power for the marine engine, it became important to control the temperature of the combustion chamber and hence scavenge air coolers were placed in between the turbocharger and engine cylinder.



*Picture of a Marine Air Cooler inside the Engine room*

#### **Variable Geometry Turbine**

Variable geometry turbine or Variable Turbine Angle (VTA) is the new age technology which can work at low engine loads and eliminate the requirement of an additional engine blower from the system. The VTA provided with movable vanes are replaced with conventional fixed vanes, which can change angles to control the exhaust flow on the turbine blades. This helps the engine control, to balance the volume of air with the fuel along the entire engine load range.



*Variable Geometry Turbine*

## Dual or Two stage Turbocharger

In today's times, the ship owners have to ensure that the pollution produced by the ship's engine is under control. One such turbocharging system used for this purpose is the Dual or Two stage turbocharger, which reduces the harmful NOx emissions from the engine by 80%.

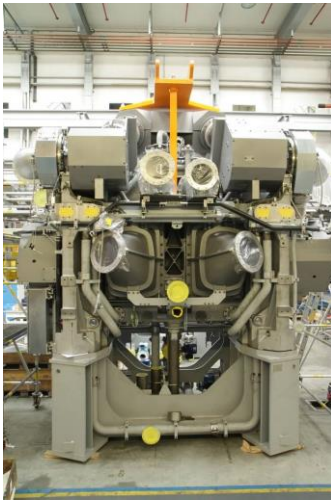

*Dual Turbocharger Turbine*

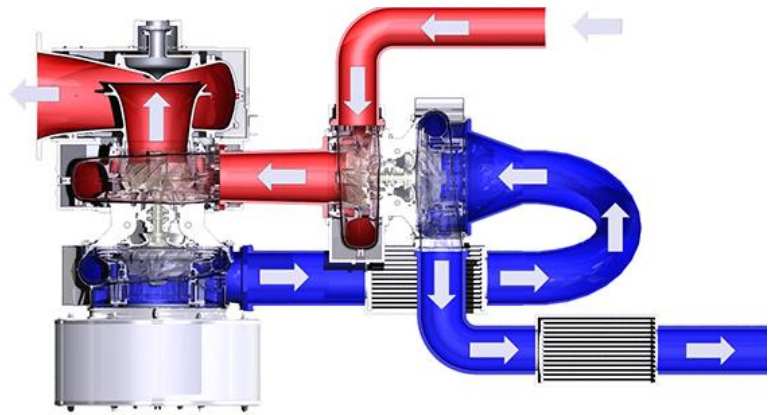

*Working principle of the dual turbocharger*

There are two different sizes of turbochargers arranged in series which provides higher pressure ratio than that provided by the best available single stage Turbo charger.

The turbine from the smaller turbo charger unit is positioned upstream of the turbine of the larger unit from the engine exhaust flow system. For air, the bigger turbocharger compressor is fed into the smaller unit's compressor. Inter cooling system is provided in between the two stages which reduce the temperature and the volume of the outlet air. This allows the second unit to be smaller making the whole system compact.

## Hybrid Turbocharger

The Hybrid turbocharger turbine is developed by Mitsubishi heavy industries and it differs from conventional turbochargers in terms of both waste recovery and fuel saving.

Exhaust gas energy is recovered to turn the compressor, which supplies scavenge air to the main engine and also generates electricity through an alternator attachment incorporated in the turbocharger known as MET hybrid turbocharger.

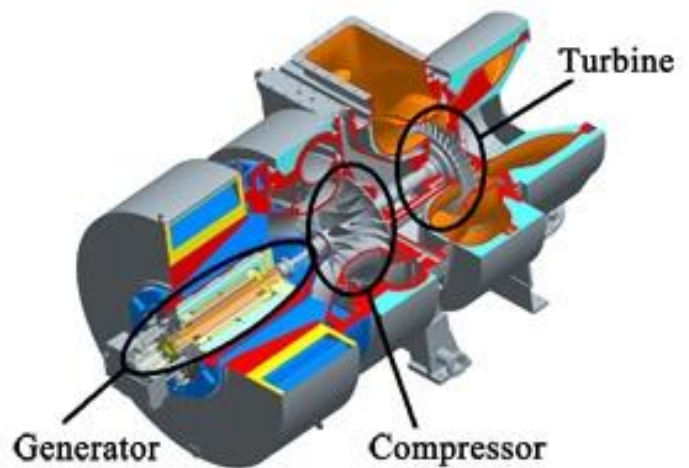

*The Hybrid Turbocharger Turbine*

---

## 6.9 - The World's First Diesel Powered Ships

Two French engineers, Frédéric Dyckhoff and Adrien Bochet, had worked together since 1899 and had installed gas and kerosene engines in canal boats with some success. Dyckhoff was a friend of Rudolf Diesel himself, and was his first licensee.

Dyckhoff and Bochet came up with an engine specifically designed to avoid unbalanced impacts on the hull of a small vessel. Their earlier internal combustion engines had caused hull failures in shallow-draft self-propelled wooden barges.

The solution was a horizontal, opposed-piston design, adapted from an earlier gas engine that the two engineers had patented. In this unique configuration, the axes of the single cylinder and the crankshaft intersected at a right-angle midway along the crank throws. There were two pistons, each pointing toward the other in the same cylinder. The single combustion chamber serving both pistons was a connecting passage over a tunnel through which the crankshaft passed. The engine had a 210- by 300-millimeter bore and stroke (for each piston). It developed 25 bhp at 360 rpm.

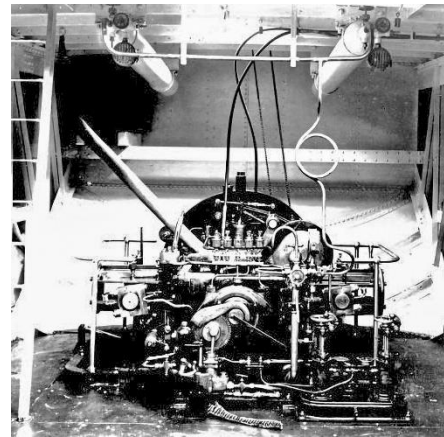

*Inside the engine room of the Petit Pierre, looking aft*

The engine was produced by Bochet's company, Sautter Harlé, at their shop in Paris. The company also produced Fresnel lenses for lighthouses, among other marine navigation products.

The barge selected for the historic diesel installation was the Petit Pierre. It was a single-screw with reversible propeller blades. The engine itself was not reversible.

The 7-mile maiden voyage took place on September 30, 1903. It was enough of a success that Dyckhoff sent a picture postcard to Rudolf Diesel describing the performance. On October 25, Diesel visited and was treated to a day trip on the Petit Pierre. Thus, the Petit Pierre is the first marine diesel-powered vessel.

At about the same time in 1903, Swedish and Russian engineers produced a larger and more advanced barge.



*A 1903 postcard showing the self-propelled barge Petit Pierre. The postcard is signed by one of the engineers who designed and developed the barge's unique diesel engine.*

---

The Nobel company had been looking at the new diesel technology as a way to overcome two problems in its oil transportation network. Russian steam locomotives and boats were burning heavy residual oils very inefficiently. This included sidewheel barges and tugs on the Volga River. Also, oil as cargo had to be transferred to rail cars at the northern end of the Volga waterway. The company wanted to use a new and larger river-canal-lake system, but there were as yet no practical, propeller-driven tankers of adequate size and power.

The solution was “Vandal”, a triple-screw tanker and the world’s first diesel-electric vessel. It was 245 feet long with a beam of 32 feet and a draft of 6 feet.

The Vandal had three diesel engines from Sickla in Sweden, each with three cylinders and developing 120 bhp at 240 rpm. The engines were midship-mounted. Each was connected to a generator, wired to a motor, and connected to a propeller shaft.

It started service in the spring of 1903. The cargo capacity was 820 metric tons.

It’s not clear how long the Petit Pierre with its unique one-cylinder, two-piston diesel engine stayed in service on the French and Belgian canals. The Vandal, though, operated for 10 years on the 2,000-mile route between the Caspian Sea and St. Petersburg.

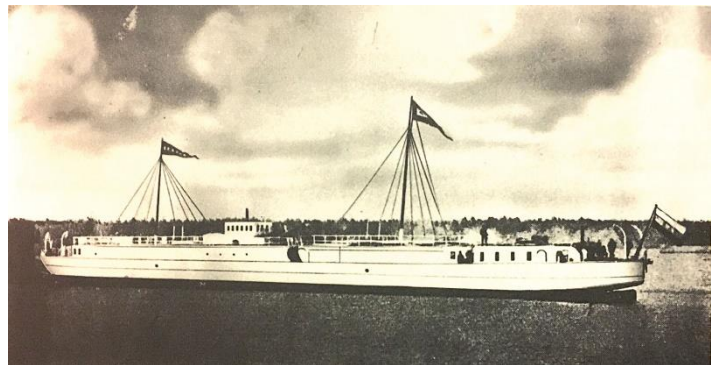

*M/S Vandal, 1903*

In fact, the Vandal was so successful that the Nobel company ordered another diesel-powered barge, the Ssarmat. It was the same size as the Vandal, but was powered by two larger diesel four-cylinder engines adapted from a stationary model. Each engine developed 180 bhp at 260 rpm. Unlike in the Vandal, the engines were placed near the stern and turned propellers via a semi-electric drive, which proved to be more efficient than the Vandal all-electric one. The Ssarmat also had a single-cylinder 10 bhp auxiliary diesel engine. The Ssarmat ran with its original engines from 1904 to 1923.



---

## 6.10 - The First Fully Diesel-Powered Vessel

Selandia was unique when compared to the other ships, that's because the ship was completely and fully diesel powered instead of the fuel being an ancillary propellant. This factor alone contributed to the vessel being anointed with the title of the first motor ship when it was launched in the year 1912.

The MS Selandia was built to carry both voyagers as well as cargo. Unlike her other peers, the vessel was constructed without the conventional funnel and the exhaust fumes were ventilated through an opening in the main mast of the vessel. For a ship of that era, the passenger ship was extremely grand and catered to the crème de la crème of the oceanic voyagers.

Owned by the East Asiatic Company, the vessel was built in the Danish Burmesiter and Wain shipbuilding yard in the year 1911.

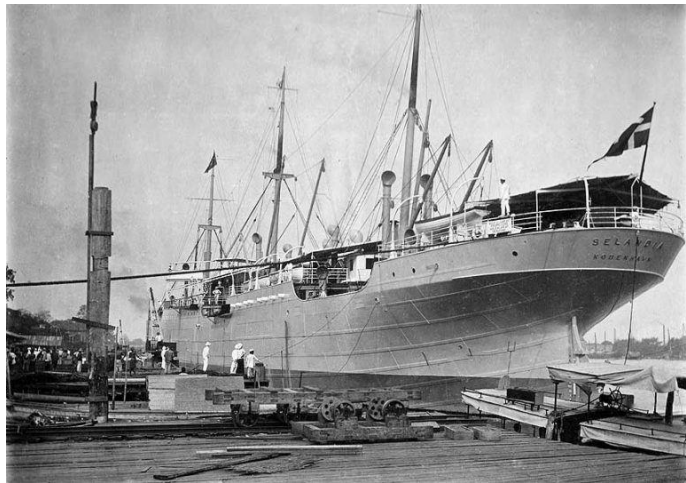

*MS Selandia, 1912*

It is said that after the notable success of the vessel, the shipbuilding company was inundated with offers to construct ships with similar propelling capabilities.

The Selandia measured 370 feet (112 m) lengthwise and 53 feet (16,1 m) width wise with a DWT of almost 7,000 tonnes. Equipped with two engines, each with eight piston chambers (cylinders), the vessel offered a power of 1,250 horsepower. The speed offered was 11 knots with an international operational ambit extending from European to South Asian oceanic waters.

---

## CHAPTER 7 – THE GAS TURBINE

A gas turbine, also called a combustion turbine, is a type of continuous and internal combustion engine.

**The main elements common to all gas turbine engines are:**

1. an upstream rotating gas compressor
2. a combustor
3. a downstream turbine on the same shaft as the compressor.

The diesel engine also displaced ships with gas turbine propulsion. Even this type of propulsion was extremely uneconomical in that it, for one, required the same top-quality, expensive fuel as that of an airplane jet engine and on top of that, it had an efficiency of only 21 % which was – at least in comparison to that of a diesel engine – awfully low. Most ships with gas turbine propulsion were converted to diesel engine propulsion after a few years.

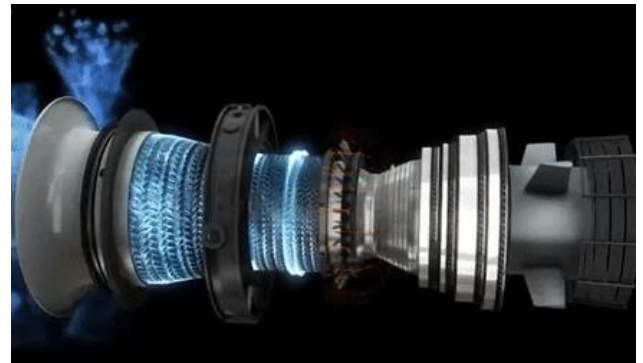

*Animated Operation of the Gas Turbine*

The gas turbine works as following, atmospheric air flows through the compressor that brings it to higher pressure; energy is then added by spraying fuel into the air and igniting it so that the combustion generates a high-temperature flow; this high-temperature pressurized gas enters a turbine, producing a shaft work output in the process, used to drive the compressor; the unused energy comes out in the exhaust gases that can be repurposed for external work, such as directly producing thrust in a turbojet engine, or rotating a second, independent turbine (known as a power turbine) that can be connected to a fan, propeller, or electrical generator.

The purpose of the gas turbine determines the design so that the most desirable split of energy between the thrust and the shaft work is achieved. Gas turbines are open systems and do not reuse the same air.

Gas turbines are used to power aircraft, trains, ships, electrical generators, pumps, gas compressors, and tanks.

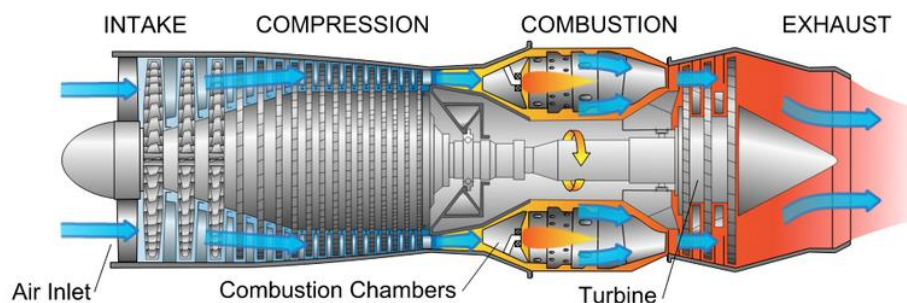

*Gas Turbine Detailed Operation*

---

## CHAPTER 8 – LNG ENGINE

### 8.1 - The history of LNG

LNG (Liquefied Natural Gas) shipping first became a possibility in 1959 when the Methane Pioneer, a converted WWII freighter safely transported Liquefied Natural Gas into the United Kingdom. She was the first oceangoing liquified natural gas tanker in the world. After proving that LNG can be safely transported across the ocean, the LNG shipping industry boomed and now employs 200 billion dollars annually in capital. Since the beginning of the LNG industry in 1964, international trade has increased 50 times over, production capacity has increased 10 times over, and individual ship capacity has increased 5 times over. The LNG tanker design was initially created by Worm's and Co. This design is now referred to as the Gaz Transport Design. The tanks were initially created to hold 34,000 cubic meters, but the design has transformed into 71,500 cubic meters.

Spherical LNG tanks showed up in 1973, when Hoegh built the Norman Lady, the first liquefied natural gas carrier with spherical tanks. Spherical tanks are common among modern LNG vessels. In 1999, Samsung Heavy Ind. created the largest New Membrane-type LNG carrier of its time. She was the largest single hull vessel of her time, with a length of 278.8 meters and a speed of 20.7 knots.



*Picture of the LNG Tanker Methane Pioneer*



*Scaled down model of the LNG Tanker Norman Lady*



*The LNG Tanker Arctic Princess while underway*

The Arctic Princess, delivered in 2006, was the largest LNG tanker ever created. She is 288 meters long, and has a capacity of 147,000 cubic meters. Since 2006 capacities have continued to climb. New build LNG vessels delivered to customers in 2018 are often designed to fit through the expanded Panama Canal (neopanamax) and have 170,000 cubic meter capacities.

---

## 8.2 - Boil-off gas

The natural gas that fuels dual fuel engines is carried on ships as a boiling liquid and transported at slightly higher than atmospheric pressure. When tank insulation is penetrated by any influx in heat, it will cause the temperature of the liquefied natural gas to rise, which allows for vaporization from liquid to gas. When heat penetrates the tank, the tank's pressure increases due to boil-off. The insulation of the tanks is designed with the most advanced technology. Even still, the insulation of the tanks is penetrated by heat.

The boil-off occurs during the ships voyage. During a storm, the LNG cargo moves and sloshes around in the tanks. The boil-off gas represents 0.1% - 0.25% of the ship's capacity per day. Tanks need to be maintained at a steady pressure. If the pressure in tanks is not controlled, relief or safety valves are forced to open, venting the boil-off into the atmosphere until pressure is relieved.

At this point, it has been proven that on board LNG re-liquefaction is uneconomical for most ships. Instead, the gas produced by this boil-off effect is routed to the ship's propulsion system and used as fuel for power plants such as steam boilers and dual fuel marine diesel engines. This reduces the use of bunker fuel, reducing fuel costs and equipment maintenance costs.

## 8.3 - Propulsion systems

Most propulsion systems in LNG carriers are dual fuel engines that use BOG and liquid fuels. In a steam plant, the BOG is used to fire the boilers and produce steam. The steam drives the turbines and propels the ship. An advantage of this type is that when the LNG cargo tank pressure is elevated the excessive BOG is burned simultaneously with liquid fuel. If there isn't enough BOG, liquid fuel (heavy fuel oil or HFO) is used to keep the plant operating. An alternative to the steam turbine engine is the dual-fuel marine diesel engine. Commercial ship propulsion system manufacturers such as Finland's Wärtsilä and Germany's MAN Diesel SE are producing large bore dual-fuel diesel engines.

The MAN B&W ME-GI Engines have extremely flexible fuel modes that range from 95% natural gas to 100% HFO and anywhere in between. A minimum of 5% HFO for pilot oil is required as these are compression ignition engines and natural gas is not self-combustible. Steam turbines are exclusively the primary moving source for LNG ships, even though 2-stroke diesel engines are more efficient. This is because the boil-off gas from LNG needs to be utilized.

## 8.4 - Cost Benefits

Recent research has been focused on using LNG for fuel on ships other than LNG tankers. These studies show that LNG stands out in terms of emissions reduction and reduced operational costs. Some economic incentives have been shown to be advantageous to running an LNG propulsion system. When certain systems such as waste heat recovery (using waste heat to do work rather than dissipate) are added to the power plant, significant savings can be observed. One study shows that an LNG engine with a WHR (Waste Heat Recovery) system saves money compared to a diesel engine without a WHR system. There is a higher initial investment cost but it is a cost-efficient method and an environmentally sound one.

---

## 8.5 - Environmental Issues

Natural gas consists mainly of methane, which has a much stronger greenhouse effect than CO<sub>2</sub> has in conjunction with its global warming potential. Climate impacts of methane are due largely to methane leakage. For example, there is an issue called methane slip. Methane slip is when gas leaks unburned through the engine. Methane has a GWP (20) (20-year global warming potential) which is 86x higher than CO<sub>2</sub>. If methane slip is not controlled, environmental benefits of using natural gas are reduced and can cancel out the advantages over diesel or bunker fuel due to the high greenhouse effect of the methane.

Another challenge is hazards associated with the LNG being stored at very low temperatures. Insulation of the tank is critical and there are possibilities of structural brittleness and personnel frostbite injuries.

Essentially, since it is established that LNG for ship propulsion reduces CO<sub>2</sub> and other pollutants compared to common heavy fuel oils, LNG implementation depends on these key factors: Gas availability, demand for ships, emission limits (emission-controlled areas), LNG tank installation and safety requirements. Challenges related to the use of LNG should be taken into consideration. Challenges such as the lack of infrastructure in the majority of commercial ports, crew's limited experience running engines with gas fuels, the future price of gas and the required safety measures all are critical points to be considered.

Use of LNG reduces Sulfur Oxides by nearly 100 percent and it reduces Nitrogen Oxide emission by about 85 percent. There is considerable debate as to whether use of LNG results in reduced greenhouse gas emissions, with studies finding that methane leakage negates climate benefits.

## CHAPTER 9 - HOVERCRAFTS

A hovercraft, also known as an air-cushion vehicle or ACV, is an amphibious craft capable of travelling over land, water, mud, ice, and other surfaces.

Hovercrafts use blowers to produce a large volume of air below the hull, or air cushion, that is slightly above atmospheric pressure. The pressure difference between the higher-pressure air below the hull and lower pressure ambient air above it produces lift, which causes the hull to float above the running surface. For stability reasons, the air is typically blown through slots or holes around the outside of a disk- or oval-shaped platform, giving most hovercraft a characteristic rounded-rectangle shape. Typically, this cushion is contained within a flexible "skirt", which allows the vehicle to travel over small obstructions without damage.

The idea of the modern hovercraft is most often associated with a British mechanical engineer Sir Christopher Cockerell. Cockerell's group was the first to develop the use of a ring of air for maintaining the cushion, the first to develop a successful skirt and the first to demonstrate a practical vehicle in continued use back in the 1950s to 1960s.

They are now used throughout the world as specialized transports in disaster relief, coastguard, military and survey applications, as well as for sport or passenger service. Very large versions have been used to transport hundreds of people and vehicles across the English Channel, whilst others have military applications used to transport tanks, soldiers and large equipment in hostile environments and terrain.

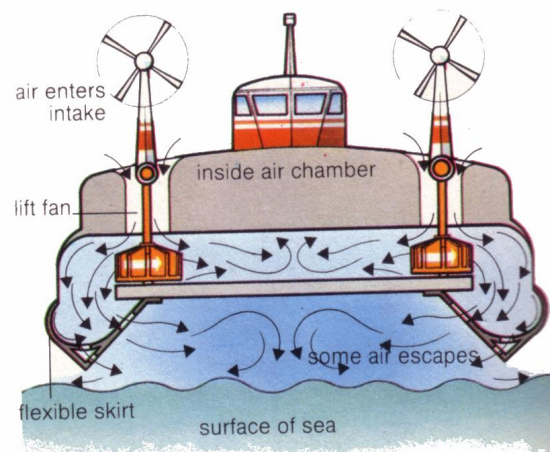

*Basic Hovercraft Function*



*U.S. Navy LCAC Hovercraft*

---

## CHAPTER 10 - VARIOUS TYPES OF PROPELLERS AND THRUSTERS

### 10.1 - Contra-Rotating Propeller

Contra-rotating propellers, also referred to as CRP, coaxial contra-rotating propellers, or high-speed propellers, apply the maximum power of usually a single piston or turboprop engine to drive two coaxial propellers in contra-rotation. Two propellers are arranged one behind the other and power is transferred from the engine via a planetary gear or spur gear transmission. Contra-rotating propellers are also known as counter-rotating propellers, although counter-rotating propellers are much more widely used when referring to airscrews on separate shafts turning in opposite directions.



*Contra Rotating Propeller Animation*

Recreational Boating: in 1982 Volvo Penta introduced a contra-rotating boat propeller branded DuoProp. The patented device has been marketed since. After the Volvo Penta patents ran out, Mercury has also produced a corresponding product, MerCruiser Bravo 3. In traditional Commercial ships contra-rotating propellers are rare, due to cost and complexity.

### 10.2 - Variable-Pitch propeller

A variable-pitch propeller or controllable-pitch propeller (CPP) is a type of propeller with blades that can be rotated around their long axis to change the blade pitch. Reversible propellers—those where the pitch can be set to negative values—can also create reverse thrust for braking or going backwards without the need to change the direction of shaft revolution.

A controllable pitch propeller (CPP) can be efficient for the full range of rotational speeds and load conditions, since its pitch will be varied to absorb the maximum power that the engine is capable of producing. When fully loaded, a vessel obviously needs more propulsion power than when empty. By varying the propeller blades to the optimal pitch, higher efficiency can be obtained, thus saving fuel. A vessel with a CPP can accelerate faster from a standstill, and can decelerate much more effectively, making stopping quicker and safer. A CPP can also improve vessel maneuverability by directing a stronger flow of water onto the rudder.



*A ship's variable-pitch propeller*

However, a fixed pitch propeller (FPP) is both cheaper and more robust than a CPP. Also, an FPP is typically more efficient than a CPP for a single specific rotational speed and load condition. Accordingly, vessels that normally operate at a standard speed (such as large bulk carriers, tankers and container ships) will have an FPP optimized for that speed. At the other extreme, a canal narrowboat will have an FPP for two reasons: speed is limited to 4 mph (to protect the canal bank) and the propeller needs to be robust (when encountering underwater obstacles).

---

### 10.3 - Voith Schneider Propeller

The Voith Schneider propeller (VSP), also known as a cycloidal drive is a specialized marine propulsion system (MPS). It is highly maneuverable, being able to change the direction of its thrust almost instantaneously. It is widely used on tugs and ferries.

From a circular plate, rotating around a vertical axis, a circular array of vertical blades (in the shape of hydrofoils) protrudes out of the bottom of the ship. Each blade can rotate itself around a vertical axis.

The internal gear changes the angle of attack of the blades in sync with the rotation of the plate, so that each blade can provide thrust in any direction, very similar to the collective and cyclic of helicopter flight controls. Its Austrian inventor, Ernst Schneider installed a prototype, back in 1928, in a 60-hp motor launch named Torqueo (Latin: I spin) and trials were carried out on Lake Constance.

By 1931 VSPs were being fitted in new vessels on Lake Constance run by the German State Railways. The first such ship to use the Voith Schneider propeller was the excursion boat Kempten. Two German 1935-type M class minesweepers M-1 and M-2 were fitted with VSPs.

The first British ship to use Voith Schneider propellers was the double-ended Isle of Wight ferry MV Lymington, launched in 1938. Some 80 ships had been installed with VSPs by the end of the 1930s, including the uncompleted 1938 German aircraft carrier Graf Zeppelin and the Japanese submarine cable laying ship Toyo-maru, 1938.

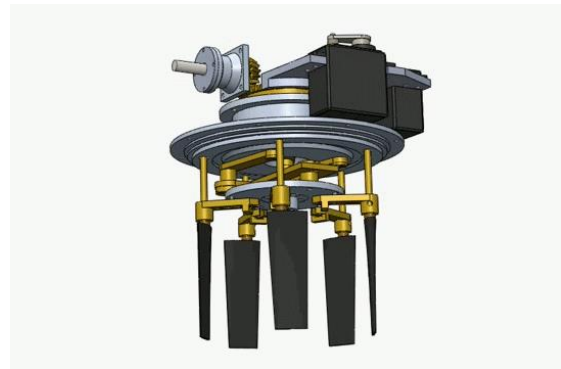

*Animated Operation of a Voith Schneider Propeller*



*Ship fitted with a Voith Schneider Propeller*

### 10.4 - Ducted Propeller

A ducted propeller, also known as a Kort nozzle, is a marine propeller fitted with a non-rotating nozzle. It is used to improve the efficiency of the propeller and is especially used on heavily loaded propellers or propellers with limited diameter. It was developed first by Luigi Stipa (1931) and later by Ludwig Kort (1934). The Kort nozzle is a shrouded propeller assembly for marine propulsion. The cross-section of the shroud has the form of a foil and the shroud can offer hydrodynamic advantages over bare propellers, under certain conditions.

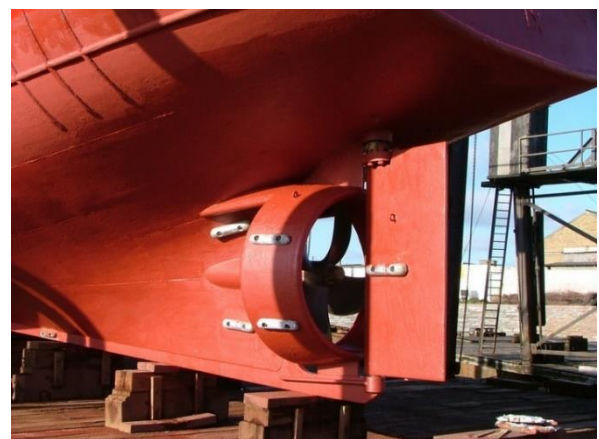

*Vessel fitted with a Ducted Propeller or otherwise known as a Kort nozzle*

Some of the advantages include, increased efficiency at lower speeds (<10 knots), better course stability and less vulnerability to debris. On the other hand some drawbacks are, reduced efficiency at higher speeds (>10 knots) and course stability when sailing astern. Ducted propellers are also used to replace rudders.



---

## 10.5 - Azimuth Thruster

An azimuth thruster is a configuration of marine propellers placed in pods that can be rotated to any horizontal angle (azimuth), making a rudder unnecessary. These give ships better maneuverability than a fixed propeller and rudder system, electrical efficiency, better use of ship space and lower maintenance costs. Ships with azimuth thrusters do not need tugboats to dock, though they may still require tugs to maneuver in difficult places.



*Siemens Schottel azimuth thrusters*

The major disadvantage of azimuth drive systems is that a ship with azimuth drive maneuvers differently compared to one with the standard propeller and rudder configuration, necessitating specialized pilot training. Another disadvantage is the increased draught of the ship.

English inventor Francis Ronalds described what he called a “Propelling Rudder” in 1859 that combined the propulsion and steering mechanisms of a boat in a single apparatus. The propeller was placed in a frame having an outer profile similar to a rudder and attached to a vertical shaft that allowed the device to rotate in plane while spin was transmitted to the propeller.

The modern azimuth thruster using the Z-drive transmission was invented in 1950 by Joseph Becker, the founder of Schottel in Germany, and marketed as the Ruder propeller. Becker was awarded the 2004 Elmer A. Sperry Award for the invention. This kind of propulsion was first patented in 1955 by Pleuger.

In the late 1980s, ABB Group developed the Azipod thruster with the motor located in the pod itself.

## 10.6 - Hi-FIN Propeller Attachment

The fuel saving propeller attachment device, named Hi-FIN, is an attachment to the hub of the propeller, allowing it to generate countering swirls to offset the swirls created by the propeller itself, and thus improves propulsion efficiency. It is patented by South Korea’s Hyundai Heavy Industries (HHI).

The energy-saving device has been installed on the 162,000-cu.m LNG carrier ordered by Maran Gas, and fuel saving of up to 2.5% is expected compared to the same type of vessels without the Hi-FIN.



*Hi-FIN attached to a ship's propeller*

“If the fuel saving ratio is calculated on the basis of an 8,600 teu container ship, the owners or operators of the containership can save about \$750,000 per year or \$19m for 25 years, an estimated lifetime of the ship,” HHI said.

HHI has won orders of Hi-FIN for over 30 ships to date and it expects more orders on ships including VLCCs, LPG carriers and container ships.

---

## 10.7 - The Azipod Thruster

In 1987, the Finnish National Board of Navigation made a co-operation proposal to the multinational electrical equipment corporation ABB Group and the Finnish shipbuilder Masa-Yards for the development of a new type of electric propulsion unit. Prior to this, the companies had been working together for decades in the field of diesel-electric propulsion systems.

Azipod is an electric podded azimuth thruster produced by ABB Group. Developed in Finland jointly by the shipbuilding company Masa-Yards and ABB. Azipod is a marine propulsion unit consisting of a fixed pitch propeller mounted on a steerable gondola ("pod") which also contains the electric motor driving the propeller.



*ABB Azipod Unit Internals Showcase*

Although "Azipod" is a registered brand name, it is sometimes used incorrectly as a generic trademark for podded propulsion units manufactured by other companies.

In the Azipod unit, the electric motor is mounted inside the propulsion unit and the propeller is connected directly to the motor shaft. Electric power for the propulsion motor is conducted through slip rings that let the Azipod unit rotate 360 degrees about the vertical axis.



*Closeup of one of USCGC Mackinaw's 3.3 MW Azipod units*

Because Azipod units utilize fixed-pitch propellers, power is always fed through a variable-frequency drive or cycloconverter that allows speed and direction control of the propulsion motors.

The pod's propeller usually faces forward because in this pulling (or tractor) configuration the propeller is more efficient due to operation in undisturbed flow. Because it has the ability to rotate around its mount axis, the pod can apply its thrust in any direction.

Azimuth thrusters allow ships to be more maneuverable and enable them to travel backward nearly as efficiently as they can travel forward. In order to get the most out of it, ship handling training on simulators and manned models is required.

The podded design typically achieved a 9% better fuel efficiency than the conventional propulsion system when it was first installed in the 1990s. Improvements to the conventional design have shrunk the gap to 6%-8%, but on the other hand the hydrodynamic flow around the Azipod has been improved by fin retrofits and a dynamic computer optimization of the respective operating angles of the pods in multipod installations, yielding overall efficiency improvements now in the range of 18%.

## 10.8 - Outboard Motor

An outboard motor is a propulsion system for boats, consisting of a self-contained unit that includes an engine, gearbox and propeller or jet drive, designed to be affixed to the outside of the stern. They are the most common motorized method of propelling small watercrafts. As well as providing propulsion, outboards provide steering control, as they are designed to pivot over their mountings and thus control the direction of thrust. The skog also acts as a rudder when the engine is not running. Unlike inboard motors, outboard motors can be easily removed for storage or repairs.

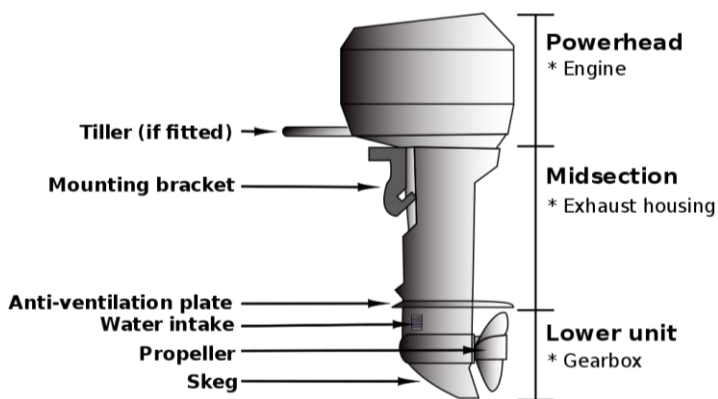

*Basic parts of an outboard Motor*

## CHAPTER 11 - CATERPILLAR

An early uncommon means of boat propulsion was the water caterpillar. This moved a series of paddles on chains along the bottom of the boat to propel it over the water and preceded the development of tracked vehicles. The first water caterpillar was developed by Joseph-Philibert Desblanc in 1782 and propelled by a steam engine. In the United States the first water caterpillar was patented in 1839 by William Leavenworth of New York. It was used for canal traffic half a century before the actual invention of land caterpillars.

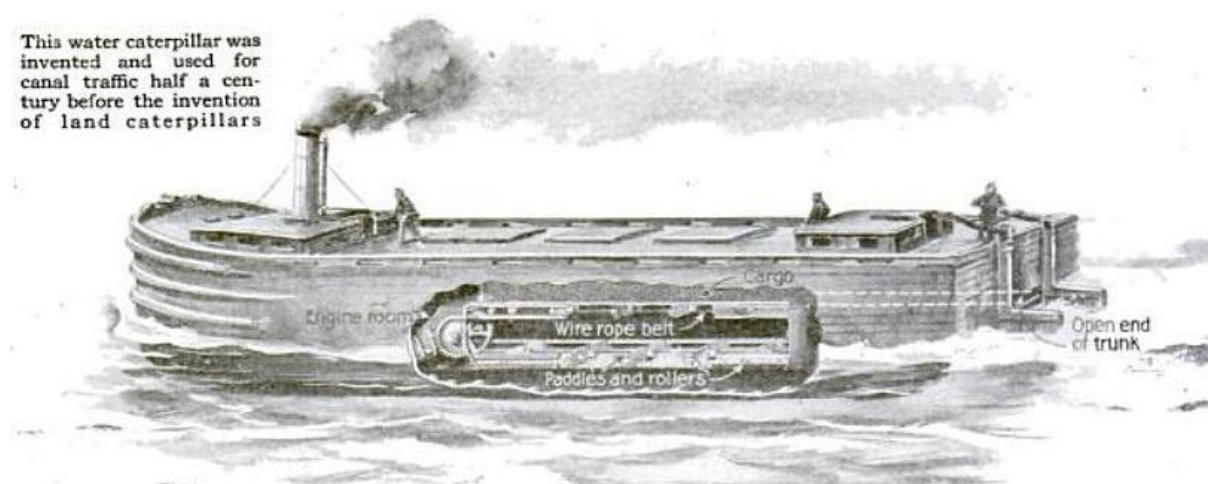

*The water caterpillar boat propulsion system*

---

## CHAPTER 12 - BIODIESEL POWERBOAT

The Earthrace is one of the most unusual-looking vessels in the world. It's one of the greenest vessels around, a showcase of environmentally friendly technologies such as low-emission engines, non-toxic anti-fouling bottom paint and a fuel-efficient hull design. It also happens to be one of the wildest-looking boats ever conceived.

The twin 8.3L 540hp and 1,273 lb-ft of torque Cummins Mercruiser QSC-540 straight-six turbocharged engines can propel Earthrace as fast as 45 knots (more than 50 mph). With a fuel capacity of 2,500 gallons, the range of the Earthrace is more than 3,000 miles between fill-ups. The sources for biodiesel are as varied as the locations the boat will visit in its voyage.



*The Powerboat Earthrace underway*

According to Bethune, the fuel for the boat can be made with salvaged french-fry grease, refined soybean oil, or even hard fat from livestock. Reportedly, the boat refueled in Hawaii on biodiesel made from "the drippings of cruiser liners' deep fryers".

As for the exotic hull design, a wave-piercer has a very fine bow (the pointy end) with minimal reserve buoyancy (in contrast to that large frontal volume of a freighter) in order to minimize vertical motion over ocean swells.

When encountering a wave, the narrow hull spears through the water rather than riding over the top. So those fins sticking above the cabin aren't merely for show but actually have air intakes that remain above the waves, even if the rest of the boat is underwater. Indeed, Bethune says he's taken as much as 14 feet of water over the top in heavy seas.

Another important aspect of Earthrace is the use of advanced composites, namely carbon fiber and Kevlar, throughout the layup of the hull. Due to the construction material, the interior is mostly basic black. The accommodations are utilitarian, with one toilet, a few bunk beds, a small galley and a cockpit that looks like it was lifted from a stealth fighter jet.

---

## CHAPTER 13 - ANIMAL POWER

Experiment was an early 19th-century boat powered by horses and incorporated the idea of a screw propeller, which was a new idea at the time.

The horse-powered ferry was a 12-ton, three-masted boat, it was about 100 feet (30.48 m) long and had a 20 feet (6.1 m) beam. She was made in 1807 to 1810, depending on the source. It was propelled by a "goose-foot paddle," a large mechanical screw propeller in the

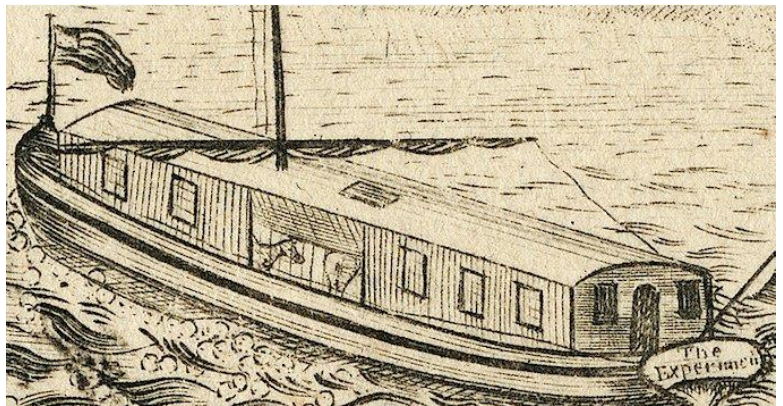

*Sketch of the horse powered boat, by William Hamlin, 1808*

water instead of a paddle wheel at water surface. The new technology devised by Grieve and Wilkinson was powered by eight horses on a treadmill. The technology to propel the boat upstream was originally invented by David Grieve and granted a patent 24 February 1801 in the category of "Boats to ascend rivers".

It is reported that Experiment made one unsuccessful voyage, as it ran aground on the return trip. The mechanism and associated parts were put together by Ephraim Southworth; little thought was put into the construction and it was poorly built. The maiden voyage was in June 1809 with a group of gentlemen from the Grand Lodge of the State. The first attempt of the "Screw Boat" began at Jackson's Wharf on Eddy's Point near Providence, Rhode Island, with a destination of Pawtuxet Village.

The eight horses for the "horse power" were owned by Marvin Morris; they were connected to a poorly designed contraption to make the boat move. It obtained a top speed of four knots with the help of the tide going in her direction and the wind on her back. It managed to get to Pawtuxet Village, where there was much celebration over its success. The return trip, however, resulted in humiliation when a gust of wind drove Experiment onto mud flats, causing its demise.

---

## CHAPTER 14 - NUCLEAR PROPULSION

Nuclear marine propulsion is the propulsion of a ship or a submarine with heat provided by a nuclear power plant. The power plant heats water to produce steam for a turbine used to turn the ship's propeller through a gearbox or through an electric generator and motor. Naval nuclear propulsion is used specifically within naval warships such as supercarriers. A small number of experimental civil nuclear ships have been built. In other words, nuclear powered ships are basically steam turbine vessels.

Compared to oil or coal fueled ships, nuclear propulsion offers the advantages of very long intervals of operation before refueling. All the fuel is contained within the nuclear reactor, so no cargo or supplies space is taken up by fuel, nor is space taken up by exhaust stacks or combustion air intakes. However, the low fuel cost is offset by high operating costs and investment in infrastructure, so nearly all nuclear-powered vessels are military.

Nuclear power revolutionized the submarine, finally making it a true "underwater" vessel, rather than a "submersible" craft, which could only stay underwater for limited periods. It allowed submarines to run for about twenty years without needing to refuel. Food supplies and crew endurance became the only limits on a nuclear submarine's time at sea. The longest submerged cruise made public was by the HMS Warspite from November 1982 to March 1983, they stayed under water for 111 days.

### Basic Operation Principles

Most naval nuclear reactors are of the pressurized water type, with the exception of a few attempts at using liquid sodium cooled reactors. A primary water circuit transfers heat generated from nuclear fission in the fuel to a steam generator; this water is kept under pressure so it does not boil. This circuit operates at a temperature of around 250 to 300 °C (482 to 572 °F). Any radioactive contamination in the primary water is confined. Water is circulated by pumps; at lower power levels, reactors designed for submarines may rely on natural circulation of the water to reduce noise generated by the pumps.

The hot water from the reactor heats a separate water circuit in the steam generator. The water turns to steam and passes through steam dryers on its way to the steam turbine. Spent steam at low pressure is run through a condenser cooled by seawater and returns to liquid form.

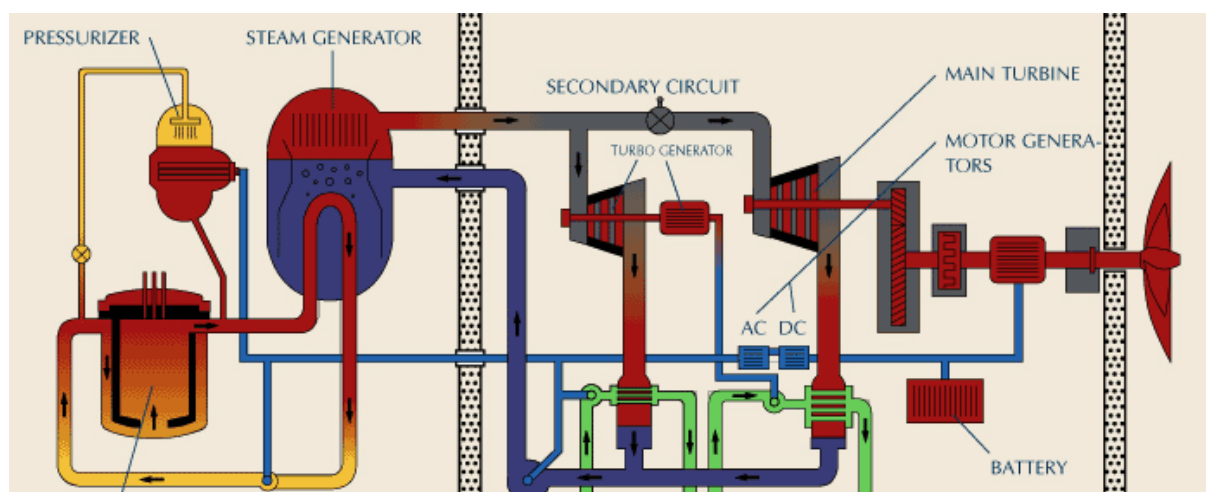

*Nuclear Reactor Operation Diagram*

---

The water is pumped back to the steam generator and continues the cycle. Any water lost in the process can be made up by desalinated sea water added to the steam generator feed water.

In the turbine, the steam expands and reduces its pressure as it imparts energy to the rotating blades of the turbine. There may be many stages of rotating blades and fixed guide vanes. The output shaft of the turbine may be connected to a gearbox to reduce rotation speed, then a shaft connects to the vessel's propellers. In a variation of the drive system, the turbine turns an electrical generator and the electric power produced is fed to one or more drive motors for the vessel's propellers. The Russian, US and British navies rely on direct steam turbine propulsion, while French and Chinese ships use the turbine to generate electricity for propulsion (turbo-electric transmission).

Some nuclear submarines have a single reactor, but Russian submarines have two and so did USS Triton. Most American aircraft carriers are powered by two reactors, but USS Enterprise had eight. The majority of marine reactors are of the pressurized water type, although the US and Soviet navies have designed warships powered with liquid metal cooled reactors.

### **The First Nuclear-Powered Merchant ship**

NS Savannah was the first nuclear-powered merchant ship. She was built in the late 1950s at a cost of \$46.9 million (including a \$28.3 million nuclear reactor and fuel core) and launched on July 21, 1959. She was funded by United States government agencies. Savannah was a demonstration project for the potential use of nuclear energy. The ship was named after SS Savannah, the first steamship to cross the Atlantic Ocean. She was in service between 1962 and 1972 as one of only four nuclear-powered cargo ships ever built. Savannah was deactivated in 1971 and after several moves has been moored at Pier 13 of the Canton Marine Terminal in Baltimore, Maryland, since 2008.



*NS Savannah reaching the Golden Gate Bridge in 1962*

### **The First Nuclear-Powered Civilian Vessel**

Lenin is a Soviet nuclear-powered icebreaker. Launched in 1957, it was both the world's first nuclear-powered surface ship and the first nuclear-powered civilian vessel. Lenin entered operation in 1959 and worked clearing sea routes for cargo ships along Russia's northern coast. From 1960 to 1965 the ship covered over 85,000 miles during the Arctic navigation season, of which almost 65,000 were through ice. Nuclear power proved to be an ideal technology for a vessel working in such a remote area as it removed the need for regular replenishment of fuel. On April 10, 1974 the vessel was awarded the Order of Lenin. It was officially decommissioned in 1989. It was subsequently converted to a museum ship and is now permanently based at Murmansk.



*Lenin docked at Murmansk*

---

## The First Nuclear-Powered Submarine

USS Nautilus (SSN-571) was the world's first operational nuclear-powered submarine and the first submarine to complete a submerged transit of the North Pole on 3 August 1958. Her initial commanding officer was Eugene Parks "Dennis" Wilkinson, a widely respected naval officer who set the stage for many of the protocols of today's Nuclear Navy.

Because her nuclear propulsion allowed her to remain submerged far longer than diesel-electric submarines, she broke many records in her first years of operation and travelled to locations previously beyond the limits of submarines. In operation, she revealed a number of limitations in her design and construction. This information was used to improve subsequent submarines.

Nautilus was decommissioned in 1980 and designated a National Historic Landmark in 1982. The submarine has been preserved as a museum ship at the Submarine Force Library and Museum in Groton, Connecticut, where the vessel receives around 250,000 visitors per year.

### Decommissioning

Decommissioning nuclear-powered submarines has become a major task for US and Russian navies. After defueling, U.S. practice is to cut the reactor section from the vessel for disposal in shallow land burial as low-level waste (see the ship-submarine recycling program). In Russia, whole vessels, or sealed reactor sections, typically remain stored afloat, although a new facility near Sayda Bay is to provide storage in a concrete-floored facility on land for some submarines in the far north.



*The Launch of USS Nautilus, 1954*



## CHAPTER 15 - THE HYDROFOIL

A hydrofoil is a lifting surface, or foil, that operates in water. They are similar in appearance and purpose to aerofoils used by aeroplanes. Boats that use hydrofoil technology are also simply termed hydrofoils. As a hydrofoil craft gains speed, the hydrofoils lift the boat's hull out of the water.



*The US Navy's XCH-4, with hydrofoils clearly lifting the hull out of the water*

The hydrofoil usually consists of a winglike structure mounted on struts below the hull, or across the keels of a catamaran in a variety of boats. As a hydrofoil-equipped watercraft increases in speed, the hydrofoil elements below the hull(s) develop enough lift to raise the hull out of the water, which greatly reduces hull drag. This provides a corresponding increase in speed and fuel efficiency.

Wider adoption of hydrofoils is prevented by the increased complexity of building and maintaining them. Hydrofoils are generally prohibitively more expensive than conventional watercrafts above a certain displacement, so most hydrofoil crafts are relatively small and are mainly used as high-speed passenger ferries, where the relatively high passenger fees can offset the high cost of the craft itself. However, the design is simple enough that there are many human-powered hydrofoil designs. Amateur experimentation and development of the concept is popular.

The foil shape moves smoothly through the water, deflecting the flow downward, which, following the Euler equations, exerts an upward force on the foil. This turning of the water creates higher pressure on the bottom of the foil and reduced pressure on the top. This pressure difference is accompanied by a velocity difference, via Bernoulli's principle, so the resulting flow field of the foil has a higher average velocity on one side than the other.

When used as a lifting element on a hydrofoil boat, this upward force lifts the body of the vessel, decreasing drag and increasing speed. The lifting force eventually balances with the weight of the craft, reaching a point where the hydrofoil no longer lifts out of the water but remains in equilibrium. Since wave resistance and other impeding forces such as various types of drag on the hull are eliminated as the hull lifts clear, turbulence and drag act increasingly on the much smaller surface area of the hydrofoil and decreasingly on the hull, creating a marked increase in speed.

Early hydrofoils used V-shaped foils. Hydrofoils of this type are known as "surface-piercing" since portions of the V-shape hydrofoils rise above the water surface when foilborne.

### Hydrofoil types

Surface-piercing (SP) hydrofoils (usually U-shaped)

Front view

Back view

Side view

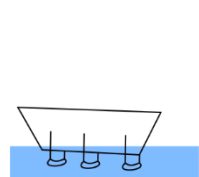
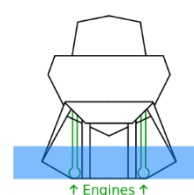
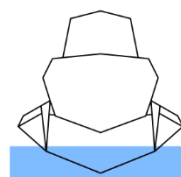

Fully submerged (FS) hydrofoils (usually shaped as inverted T or as V)

Front view

Back view

Side view

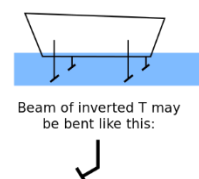
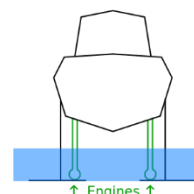
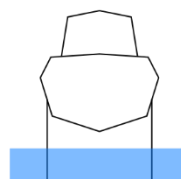

*The two types of hydrofoils: surface-piercing and fully submerged*

---

Some modern hydrofoils use fully submerged inverted T-shape foils. Fully submerged hydrofoils are less subject to the effects of wave action and therefore, more stable at sea and more comfortable for crew and passengers. This type of configuration, however, is not self-stabilizing. The angle of attack on the hydrofoils must be adjusted continuously to changing conditions, a control process performed by sensors, a computer, and active surfaces.

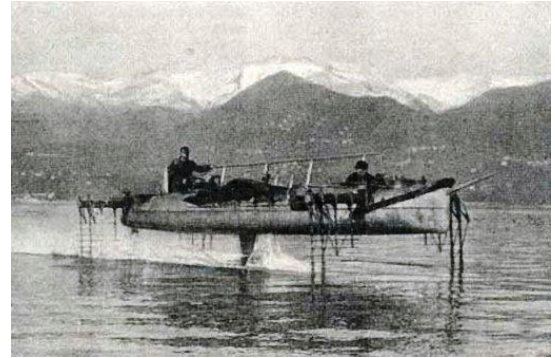

*Forlanini's hydrofoil over Lake Maggiore, 1906*

The first evidence of a hydrofoil on a vessel appears on a British patent granted in 1869 to Emmanuel Denis Farcot, a Parisian. He claimed that "adapting to the sides and bottom of the vessel a series of inclined planes or wedge formed pieces, which as the vessel is driven forward will have the effect of lifting it in the water and reducing the draught.". Italian inventor Enrico Forlanini began work on hydrofoils in 1898. Forlanini obtained patents in Britain and the United States for his ideas and designs.

German engineer Hanns von Schertel worked on hydrofoils prior to and during World War II in Germany. After the war, the Russians captured Schertel's team. As Germany was not authorized to build fast boats, Schertel went to Switzerland, where he established the Supramar company. In 1952, Supramar launched the first commercial hydrofoil, PT10 "Freccia d'Oro" (Golden Arrow), in Lake Maggiore, between Switzerland and Italy. The PT10 is one of the surface-piercing types, it can carry 32 passengers and travel at 35 knots (65 km/h; 40 mph).



*Freccia d'Oro underway, 1952*

---

## CHAPTER 16 - SKYSAILS PROPULSION SYSTEM

The SkySails propulsion system consists of a large foil kite, an electronic control system for the kite, and an automatic system to retract the kite.

The kite bears resemblance to the arc kites used in kitesurfing. However, the kite is an inflatable rather than a ram-air kite. Additionally, a control pod is used rather than direct tension on multiple kite control lines; only one line runs the full distance from kite to ship, with the bridle lines running from kite to control pod. Power to the pod is provided by cables embedded in the line; the same line also carries commands to the control pod from the ship.

The kite is launched and recovered by an animated mast or arm, which grips the kite by its leading edge. The mast also inflates and deflates the kite. When not in use, the mast and deflated kite fold away.

A conventional ship with a SkySails system burns less fuel, and has two propulsion methods, making it a type of a hybrid vehicle. The SkySails' kite propulsion utilizes the traction of high-altitude wind power. Up to 100 million tons of carbon emissions every year could be saved by widespread use of SkySails technology, according to the International Maritime Organization. Other companies, such as California-based KiteShip, have built similar technology.

The Wessels Shipping Company entered into a partnership with SkySails to pilot and test the system on their ship MV Michael A. in 2007. They then ordered further systems, the first of which was retrofitted to the MV Theseus.

MS Beluga SkySails was the first ship to be built using the system and the first to use a production model. The 132 m, 10,000 tonne vessel was fitted with a 160-square-metre (1,700 sq ft) kite and was launched on 17 December 2007; it departed the northern German port of Bremerhaven making its way to Guanta, Venezuela in January 2008.



*A prototype kite (production kites have areas of hundreds of square meters)*



*MS Beluga 3d render*

---

## CHAPTER 17 - THE STIRLING ENGINE

A Stirling engine is a heat engine that is operated by the cyclic compression and expansion of air or other gas (the working fluid) at different temperatures, resulting in a net conversion of heat energy to mechanical work. More specifically, the Stirling engine is a closed-cycle regenerative heat engine with a permanent gaseous working fluid. Closed-cycle, in this context, means a thermodynamic system in which the working fluid is permanently contained within the system and regenerative describes the use of a specific type of internal heat exchanger and thermal store, known as the regenerator. Strictly speaking, the inclusion of the regenerator is what differentiates a Stirling engine from other closed cycle hot air engines.

Originally conceived in 1816 as an industrial prime mover to rival the steam engine, its practical use was largely confined to low-power domestic applications for over a century. Robert Stirling is considered as one of the fathers of hot air engines who succeeded in building, in 1816, the first working hot air engine.

The three major types of Stirling engines are distinguished by the way they move the air between the hot and cold areas:

1. The **alpha** configuration has two power pistons, one in a hot cylinder, one in a cold cylinder and the gas is driven between the two by the pistons. It is typically in a V-formation with the pistons joined at the same point on a crankshaft. This type of engine has a high power-to-volume ratio but has technical problems because of the usually high temperature of the hot piston and the durability of its seals. In practice, this piston usually carries a large insulating head to move the seals away from the hot zone at the expense of some additional dead space.

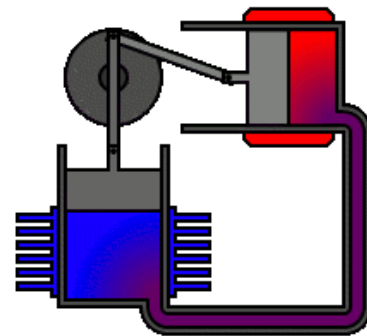

*The complete alpha type Stirling cycle. Note that if the application of heat and cold is reversed, the engine runs in the opposite direction without any other changes.*

2. The **beta** configuration has a single cylinder with a hot end and a cold end, containing a power piston and a 'displacer' that drives the gas between the hot and cold ends. It is typically used with a rhombic drive to achieve the phase difference between the displacer and power pistons but they can be joined 90 degrees out of phase on a crankshaft.

Unlike the alpha type, the beta type avoids the technical problems of hot moving seals, as the power piston is not in contact with the hot gas.

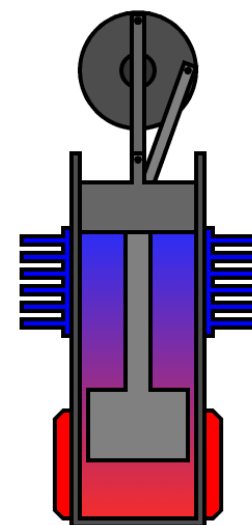

*The complete beta type Stirling cycle*

- 
3. The **gamma** configuration has two cylinders: one containing a displacer, with a hot and a cold end, and one for the power piston; they are joined to form a single space, so the cylinders have equal pressure; the pistons are typically in parallel and joined 90 degrees out of phase on a crankshaft. This configuration produces a lower compression ratio because of the volume of the connection between the two but is mechanically simpler and often used in multi-cylinder Stirling engines.

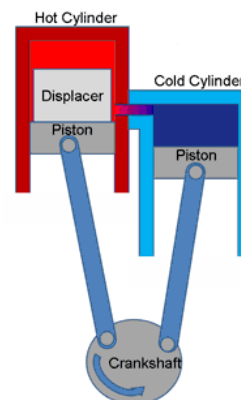

*The Gamma Type Stirling Engine*

The Stirling engine could be well suited for underwater power systems where electrical work or mechanical power is required on an intermittent or continuous level. General Motors have undertaken a considerable amount of work on advanced Stirling cycle engines which include thermal storage for underwater applications. United Stirling, in Malmö, Sweden, are developing an experimental four-cylinder engine using hydrogen peroxide as an oxidant in underwater power systems.

The SAGA (Submarine Assistance Great Autonomy) submarine became operational in the 1990s and is driven by two Stirling engines supplied with diesel fuel and liquid oxygen. This system also has potential for surface-ship propulsion, as the engine's size is less of a concern, and placing the radiator section in seawater rather than open air (as a land-based engine would be) allows for it to be smaller.

Swedish shipbuilder Kockums has built 8 successful Stirling powered submarines since the late 1980s. They carry compressed oxygen to allow fuel combustion submerged, providing heat for the Stirling engine. They are currently used on submarines of the Gotland and Södermanland classes. They are the first submarines in the world to feature Stirling air-independent propulsion (AIP), which extends their underwater endurance from a few days to several weeks.

---

## CHAPTER 18 - SOLAR-POWERED PROPULSION

While a significant majority of water vessels are powered by diesel engines, with sail power and gasoline engines also popular, boats powered by electricity have been used for over 120 years. Electric boats were very popular from the 1880s until the 1920s, when the internal combustion engine became dominant. Since the energy crises of the 1970s, interest in this quiet and potentially renewable marine energy source has been increasing steadily, especially as more efficient solar cells have become available, for the first time making possible motorboats with an infinite range like sailboats. The first practical solar boat was probably constructed in 1975 in England. In 2012, PlanetSolar became the first ever solar electric vehicle to circumnavigate the globe.



*Planetsolar, 2012*

Solar panels can be built into the boat in reasonable areas in the deck, cabin roof or as awnings. Some solar panels, or photovoltaic arrays, can be flexible enough to fit to slightly curved surfaces and can be ordered in unusual shapes and sizes. Nonetheless, the heavier, rigid mono-crystalline types are more efficient in terms of energy output per square meter. The efficiency of solar panels rapidly decreases when they are not pointed directly at the sun, so some way of tilting the arrays while under way is very advantageous. Sun21 sailed the Atlantic from Seville to Miami and from there to New York. It was the first crossing of the Atlantic powered only by solar.



*The Solar-Powered Sun21*

## CHAPTER 19 - WINDMILL SHIP

A windmill ship, wind energy conversion system ship or wind energy harvester ship propels itself by use of a wind turbine to drive a propeller. These are a pretty rare category. They use wind power, through a mechanical or electrical transmission to the propeller. Where transmission is electric, storage batteries may also be used to allow power generated at one time to be used for propulsion later on. There are safety considerations regarding the spinning blades, especially in strong winds. It is important that the boat is big enough that the turbine can be mounted out of the way of all passengers and crew under all circumstances, including when alongside a dock, a bank or a pier.



*"Thrippence" Windmill Catamaran with a 6-foot-tall mill*

It is also important that the boat is big enough and stable enough that the top hamper created by the turbine on its pole or mast does not compromise its stability in strong winds or gales. Large enough wind generators could produce a completely wind-powered electric boat.

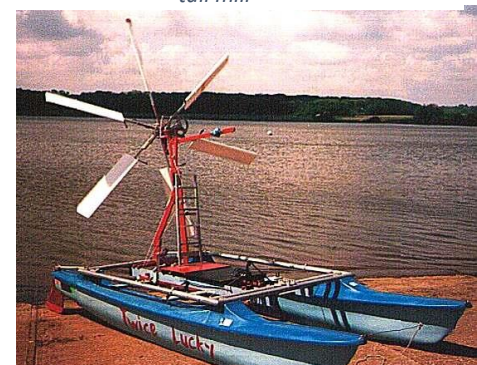

*Peter Worsley's Windmill Catamaran "Twice Lucky"*

Windmill ships should not be confused with rotor ships, which instead rely on the Magnus effect for propulsion.

## CHAPTER 20 - WATER-JET PROPULSION

A pump-jet, hydro jet, or water jet is a marine system that produces a jet of water for propulsion. The mechanical arrangement may be a ducted propeller (axial-flow pump), a centrifugal pump, or a mixed flow pump which is a combination of both centrifugal and axial designs. The design also incorporates an intake to provide water to the pump and a nozzle to direct the flow of water out of the pump. The required power is conventionally produced using two or more marine diesel engines that work on either two or four-stroke modes.



Two of four KaMeWa waterjets on the high-speed ferry Discovery

A pump-jet works by having an intake (usually at the bottom of the hull) that allows water to pass underneath the vessel into the engines. Water enters the pump through this inlet. The pump can be of a centrifugal design for high speeds, or an axial flow pump for low to medium speeds. The water pressure inside the inlet is increased by the pump and forced backwards through a nozzle. With the use of a reversing bucket, reverse thrust can also be achieved for faring backwards, quickly and without the need to change gear or adjust engine thrust. The reversing bucket can also be used to help slow the ship down when braking. This feature is the main reason pump jets are so maneuverable.

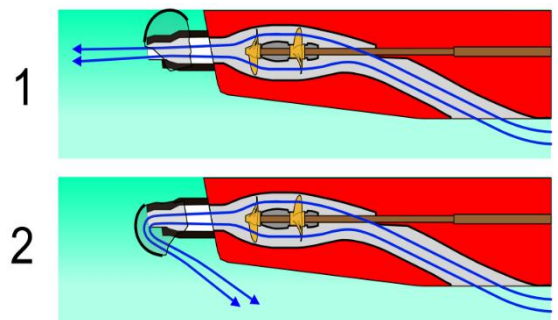

This image illustrates the workings of a reversing bucket.  
1: Forward thrust, reversing bucket disengaged 2: Reverse thrust, reversing bucket pushes the thrust flow backwards

The nozzle also provides the steering of the pump-jets. Plates, similar to rudders, can be attached to the nozzle in order to redirect the water flow to port and starboard. In a way, this is similar to the principles of air thrust vectoring, a technique which has long been used in launch vehicles (rockets and missiles) then later in military jet-powered aircrafts. This provides pump jet-powered ships with superior agility at sea. Another advantage is that when faring backwards by using the reversing bucket, steering is not inverted, as opposed to propeller-powered ships.

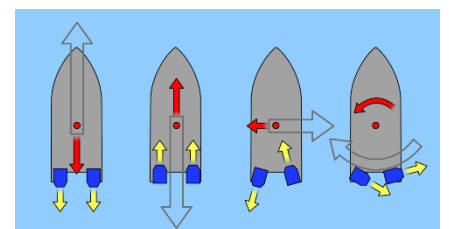

Forward, back, side & turn by pump-jet

### History

In April 1932, Italian engineer Secondo Campini demonstrated a pump-jet propelled boat in Venice, Italy. The boat achieved a top speed of 28 knots (32 mph; 52 km/h), a speed comparable to a boat with a conventional engine of similar output. The Italian Navy, who had funded the development of the boat, placed no orders but did veto the sale of the design outside of Italy. The first modern jetboat was developed by New Zealand engineer Sir William Hamilton in the mid-1950s.

---

## Uses

Pump-jets were once limited to high-speed pleasure crafts (such as jet skis and jetboats) and other small vessels, but since the 2000's the desire for high-speed vessels has increased and thus the pump-jet is gaining popularity on larger crafts, military vessels and ferries. On these larger crafts, they can be powered by diesel engines or gas turbines. Speeds of up to 40 knots (45 mph; 75 km/h) can be achieved with this configuration, even with a bigger displacement hull.



*Finnish Navy Hamina Class Missile Boat*

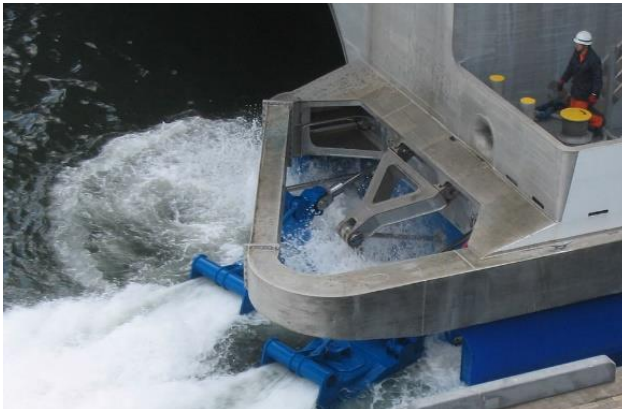

*A view of pump-jets operating*

Pump-jet powered ships are very maneuverable. Examples of ships using pump jets are the fast patrol boat Dvora Mk-III craft, Car Nicobar-class patrol vessels, Valour-class frigates, the Stena High-speed Sea Service ferries, the United States Seawolf-class and Virginia-class, as well as the Russian Borei-class submarines and the United States littoral combat ships.



## CHAPTER 21 - THE FLETTNER ROTOR

The Flettner rotor is a smooth cylinder with disc end plates which is spun along its long axis and as air passes at right angles across it, the Magnus effect causes an aerodynamic force to be generated in the direction perpendicular to both the long axis and the direction of airflow. Named after German aviation engineer and inventor Anton Flettner.

The Magnus effect is named after Gustav Magnus, the German physicist who investigated it. It describes the force generated by fluid flow over a rotating body, at right angles to both the direction of flow and the axis of rotation.

In a rotor ship the rotors stand vertically and lift is generated at right angles against the wind, to drive the ship forwards. A conventional powered water propeller may or may not be provided for additional operational flexibility.

An early prototype, the Baden Feltner (formerly the Buckau) crossed the Atlantic in 1925, but interest was not revived until energy-saving became a major concern in the new millennium.

The E-Ship 1 was launched in 2008 and new vessels continue to appear.

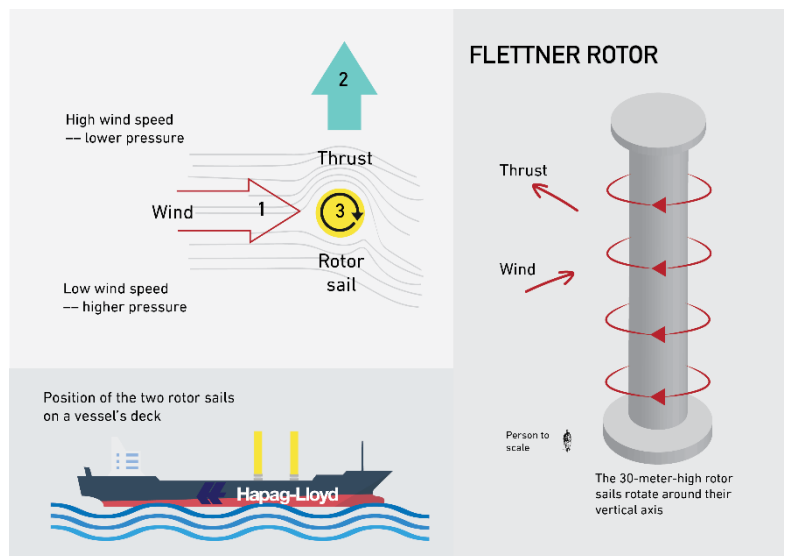

*The Flettner Rotor using the Magnus Effect to propel the vessel*

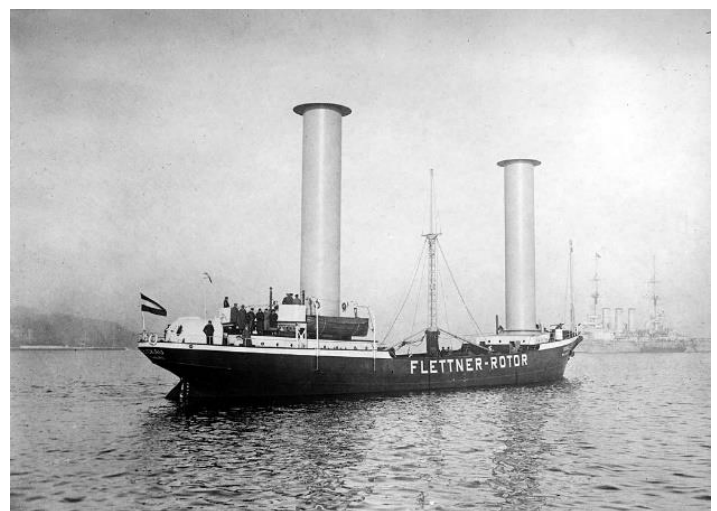

*The Buckau, the first vehicle to be propelled by a Flettner rotor*

## CHAPTER 22 - HYDROGEN PROPULSION

A hydrogen ship is a hydrogen fueled ship, power-assisted by an electric motor that gets its electricity from a fuel cell.

A fuel cell is an electrochemical cell that converts the chemical energy of a fuel (often hydrogen) and an oxidizing agent (often oxygen) into electricity through a pair of redox reactions. Fuel cells are different from most batteries in requiring a continuous source of fuel and oxygen (usually from air) to sustain the chemical reaction, whereas in a battery the chemical energy usually comes from metals and their ions or oxides that are commonly already present in the battery, except in flow batteries.

Fuel cells can produce electricity continuously for as long as hydrogen and oxygen are supplied. In addition to this pure hydrogen type, there are hydrocarbon fuels for fuel cells, including diesel, methanol (direct-methanol fuel cells and indirect methanol fuel cells) and chemical hydrides. The waste products with these types of fuel are carbon dioxide and water.

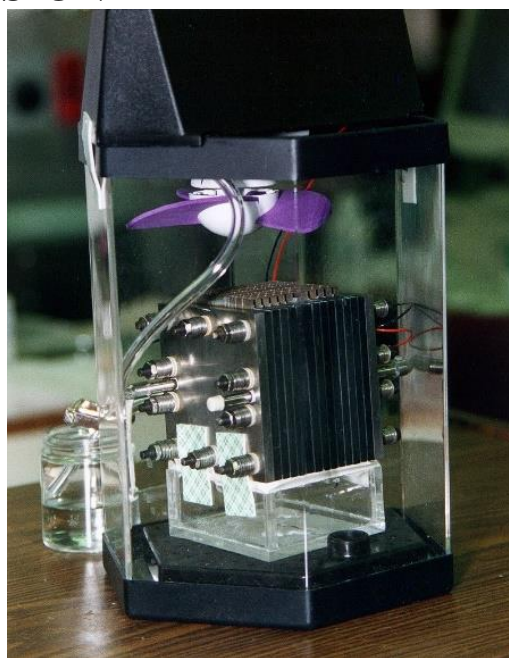

*Demonstration model of a direct-methanol fuel cell (black layered cube) in its enclosure.*

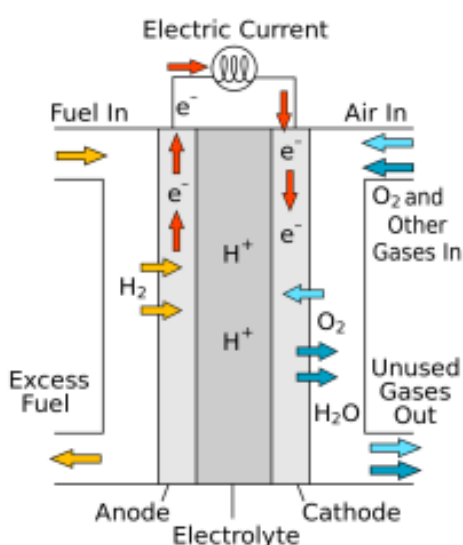

*Scheme of a proton-conducting fuel cell*

The first fuel cells were invented by Sir William Grove in 1838. The first commercial use of fuel cells came more than a century later following the invention of the hydrogen–oxygen fuel cell by Francis Thomas Bacon in 1932. The alkaline fuel cell, also known as the Bacon fuel cell after its inventor, has been used in NASA space programs since the mid-1960s to generate power for satellites and space capsules. Since then, fuel cells have been used in many other applications.

Fuel cells are used for primary and backup power for commercial, industrial and residential buildings and in remote or inaccessible areas. They are also used to power fuel cell vehicles, including forklifts, automobiles, buses, boats, motorcycles and submarines.

---

## Practical Developments

In 2000, the 22-person Hydra ship was demonstrated, and in 2003 the Duffy-Herreshoff water-taxi went into service. 2003 saw the debut of Yacht No. 1, as well Hydroxy3000. The AUV DeepC and Yacht XV 1 were shown in 2004.



*Hydrogen boat Hydra, 2000*

In 2005 the first example of the Type 212 submarine, which is powered underwater by fuel cells, went into service with the German navy. Type 212 is the first fuel cell propulsion system equipped submarine series.



*Type 212 submarine-U-34 underway*

In 2006 the 12-person Xperiance was debuted, as well as the Zebotec. In 2007 both the 8-person Tuckerboot and the Canal boat Ross Barlow debuted and in 2008 the 100-passenger Zemships project Alsterwasser went into service in Hamburg. Also, in 2009 the Nemo H2 and the Frauscher 600 Riviera HP went into service. In 2013 the Hydrogenesis Passenger Ferry project went into service.

## Pollution

In 2010, Hjalti Pall Ingolfsson from Icelandic New Energy has commented that ships are quickly becoming the biggest source of air pollution in the European Union. It is estimated that by 2021 emissions of sulfur dioxide and nitrogen oxides from ships will exceed land-based emissions in Europe. A big issue to be dealt with would be the storage of hydrogen on ships, given that there would be no opportunity to refill them when out at sea, although one can use wind power and solar panels to generate electricity from the ocean while they are far from the shore and produce onboard hydrogen.

---

## CHAPTER 23 - BATTERY-ELECTRIC PROPULSION

Battery-electric propulsion first appeared in the latter part of the 19th century, powering small lake boats. These relied entirely on lead-acid batteries for electric current to power their propellers. Elco (the Electric Launch Company) evolved into the industry leader, later expanding into other forms of vessels, including the iconic World War II PT boat.

In the early part of the 20th century electric propulsion was adapted to be used in submarines. As underwater propulsion, driven exclusively by heavy batteries, was both slow and of limited range and timespan, rechargeable battery banks were developed. Submarines were primarily powered by combined diesel-electric systems on the surface, which were much faster and allowed for dramatically expanded range, charging their battery systems as necessary for still limited subsurface action and duration. The experimental Holland V submarine led to the adoption of this system by the U.S. Navy, followed by the British Royal Navy.

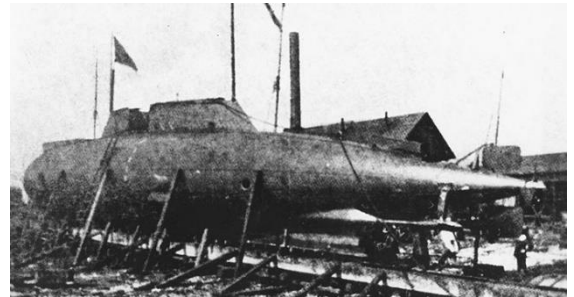

*Plunger while under construction at the Columbian Iron Works, Baltimore, Maryland*

To expand the range and duration of the submarine during World War II the German Kriegsmarine developed a snorkel system, which allowed the diesel-electric system to be utilized while the submarine was all but completely submerged. Finally, in 1952, when the USS Nautilus was launched, the world's first nuclear powered submarine, it eliminated the restrictions of both diesel fuel and limited duration battery propulsion.

Several short-range ships are built as (or converted to) pure electric vessels. This includes some powered by batteries which are recharged from shore and some shore-powered by electrical cables, either overhead or submerged (no batteries).

On November 12, 2017 Guangzhou Shipyard International (GSI) launched what may be the world's first all-electric, battery-powered inland coal carrier. The 2,000-dwt vessel will carry bulk cargo for up to 40 nautical miles per charge. The ship carries lithium-ion batteries rated at 2,400 kilowatt-hours, about the same amount as 30 Tesla Model S electric sedans.

---

## **EPILOGUE**

It's quite remarkable what the human race is capable of achieving in the short time span of a few centuries. The sea sector has always been more linked to the rest world than any other. We should all look into marine innovations because they undoubtedly interact with our individual lives in some way or another and may provide some insight into how our present daily lives came to be.

This is not the end of line. Human kind has always been fascinated with the ocean and it is an inherent part of our existence, our culture, our very essence. We will continue to venture forward, to a more innovative and hopefully greener future. This world is the legacy that we will pass on to the next generations and it is our responsibility to preserve it and make efforts to implement more environmentally sustainable marine propulsion systems to the shipping industry.

This has been a time demanding effort, to create a project that includes so much knowledge on the given subject that can be considered equivalent to all-inclusive on all marine propulsion systems known to man to this day. I hope that my project will assist and enlighten whoever comes across it in the future and is looking into the technical side of marine history.

Again, thank you so much for taking the time to read my research.

---

## BIBLIOGRAPHY

### ➤ Books-Publications

- History Of Ships - Peter Kemp
- Illustrated History of Ships&Boats - Book Author: Lionel Casson
- A Chronological History of the Origin and Development of Steam Navigation - Authors : George Henry PrebleJohn Lipton Lochhead 1883
- Engineering triggers for the development of design and evolution of marine propulsion systems by Daniel Hurmingson Dickson Maikalanga submitted to the WMU - World Maritime University
- GARDINER, R (1992). The Shipping Revolution, The Modern Merchant Shipping Conway Maritime Press, London, United Kingdom.
- GRIFFITHS, D (1990). Power Of The Great Liners: A History Of Marine Engineering, Bath Press, Avon, UK.
- Grossman, G, et al. (1993). Matching Ship Propeller and Main Engine for worldwide Use..., Marine Systems Design ICMES 93, IMER, 1993.
- GUTHRIE, J (1971). A History Of Marine Engineering, Anchor Press, Essex UK.
- HARTMANN, T (1983) 'The Guinness Book Of Ships And Shipping, Facts And Feats', JUPERLATIVES Limited,
- MORGAN, N (1990). Marine Technology Reference Book, Butterworths & Co. Publishers Ltd, Essex Great Britain.
- OSBOURNE A (1994). Modern Marine Engineers' Manual, Volume II, Second Edition, Cornell Maritime Press, Maryland USA.
- RICHARD, J D (1996). The Original Engine 1844 - 1846, of SS Great Britain. In R.A Buchanaan (ed) Engineers and Engineering Papers of The Rolt Fellows, Bath University Press, UK.
- SAIR, K.F (1981). Development Of Marine Diesels, MER. December 1981.
- SPEARS, H.C.K (1981). Steam Propulsion For Modern Ships, Trans I Mare, 1978 Paper SP6, The Institute Of Marine Engineers, London, UK.
- TAGGART, R (1969) Marine Propulsion Principles & Evolution, Gulf Publishing Company, Houston Texas, USA.
- THORSTEN, R et al. (1983). The Commercial History Of Shipping, Rinman & Lindén AB, Gotéborg, Sweden.
- TORNBLAD, J (1987). Marine Propellers And Propulsion Of Ships, KAMEWA Vickers PLC Company, K.ristenhamn, Sweden.

---

## ➤ Conferences-Speeches

- The Propulsion of Sea Ships in the Past, Present and Future, Speech by Bernd Roder on the VHT General Meeting on 11.12.2008
- The Motor Ship, (1996). "Redundancy VsReliability" 18" Annual International Marine Propulsion Conference, 21 - 22 March 1996, The Radisson SAS Hotel, Hamburg (Conclusions from the Conference held)

## ➤ Websites

- [https://en.wikipedia.org/wiki/Gas\\_turbine](https://en.wikipedia.org/wiki/Gas_turbine)
- [https://en.wikipedia.org/wiki/RMS\\_Olympic](https://en.wikipedia.org/wiki/RMS_Olympic)
- <https://en.wikipedia.org/wiki/Titanic>
- <https://en.wikipedia.org/wiki/Galley>
- <https://kraftwerkforschung.info/en/quickinfo/basic-concepts/the-difference-between-steam-and-gas-turbines/>
- [https://en.wikipedia.org/wiki/Compound\\_steam\\_engine](https://en.wikipedia.org/wiki/Compound_steam_engine)
- <https://www.britannica.com/technology/trireme>
- <https://www.discover-peloponnese.com/content/ancient-greek-warship-trireme#:~:text=The%20Trireme%20was%20invented%20at,ram%20on%20the%20s hip's%20prow.>
- <https://en.wikipedia.org/wiki/Leontophoros>
- <https://www.core77.com/posts/25224/Lignum-Vitae-Wood-So-Bad-Ass-Its-Used-to-Make-Shaft-Bearings-for-Nuclear-Submarines-and-More>
- [http://www.thepirateking.com/ships/ship\\_types.htm](http://www.thepirateking.com/ships/ship_types.htm)
- [https://en.wikipedia.org/wiki/Sailing\\_ship](https://en.wikipedia.org/wiki/Sailing_ship)
- <https://www.eolss.net/sample-chapters/C08/E3-10-03-02.pdf>
- [https://en.wikipedia.org/wiki/Dugout\\_canoe#:~:text=Dugouts%20are%20the%20oldest%20boat,than%2C%20e.g.%2C%20bark%20canoes](https://en.wikipedia.org/wiki/Dugout_canoe#:~:text=Dugouts%20are%20the%20oldest%20boat,than%2C%20e.g.%2C%20bark%20canoes)
- <https://en.wikipedia.org/wiki/Propulsion>
- [https://en.wikipedia.org/wiki/Maritime\\_history#Ancient\\_times](https://en.wikipedia.org/wiki/Maritime_history#Ancient_times)
- <https://commons.wmu.se/cgi/viewcontent.cgi?>
- [https://archive.org/stream/johnstevensameri00turn#page/n3/mode/2uparticle=2057&context=all\\_dissertations](https://archive.org/stream/johnstevensameri00turn#page/n3/mode/2uparticle=2057&context=all_dissertations)
- [https://en.wikipedia.org/wiki/Steam\\_engine](https://en.wikipedia.org/wiki/Steam_engine)
- <http://www.cctsteam.50megs.com/corbasics.htm>
- <https://marineengineeringonline.com/tag/constant-pressure-system-turbocharging/#:~:text=Exhaust%20gas%20from%20all%20cylinders,constant%20pressure%20at%20turbine%20inlet.>
- [https://en.wikipedia.org/wiki/Steam\\_turbine](https://en.wikipedia.org/wiki/Steam_turbine)
- [https://www.wikiwand.com/en/Single-\\_and\\_double-acting\\_cylinders](https://www.wikiwand.com/en/Single-_and_double-acting_cylinders)
- <http://scihi.org/thomas-savery-invention-steam-power/>
- <https://www.mby.com/gear/guide-to-foiling-technology-93079>
- <https://barcoenalquiler.es/the-strangest-vessels-in-the-world/>

- 
- <https://www.popularmechanics.com/adventure/g2998/weird-boats/>
  - [https://en.wikipedia.org/wiki/Rotor\\_ship](https://en.wikipedia.org/wiki/Rotor_ship)
  - [https://www.wikiwand.com/en/History\\_of\\_the\\_steam\\_engine#/Watt's\\_separate\\_condenser](https://www.wikiwand.com/en/History_of_the_steam_engine#/Watt's_separate_condenser)
  - [https://military.wikia.org/wiki/Ancient\\_maritime\\_history?file=Dugout\\_canoe\\_manner\\_boats\\_de\\_bry.jpg](https://military.wikia.org/wiki/Ancient_maritime_history?file=Dugout_canoe_manner_boats_de_bry.jpg)
  - <https://www.britannica.com/technology/ship/17th-century-developments>
  - [https://en.wikipedia.org/wiki/Maritime\\_history](https://en.wikipedia.org/wiki/Maritime_history)
  - <https://vadebarcos.files.wordpress.com/2020/03/evolution-of-ship-propulsion.jpg>
  - <http://webserver.dmt.upm.es/~isidoro/bk3/c17/Marine%20propulsion.pdf>
  - <https://www.hmy.com/a-timeline-of-ships-boats-and-yachts/>
  - <https://www.egr.msu.edu/~lira/supp/steam/savery.htm>
  - <https://en.wikipedia.org/wiki/Azipod>
  - [https://en.wikipedia.org/wiki/Marine\\_steam\\_engine](https://en.wikipedia.org/wiki/Marine_steam_engine)
  - <https://www.youtube.com/watch?v=QltRwiu4U2Qc>
  - [https://en.wikipedia.org/wiki/USS\\_Princeton\\_\(1843\)](https://en.wikipedia.org/wiki/USS_Princeton_(1843))
  - [https://en.wikipedia.org/wiki/HMS\\_Rattler\\_\(1843\)](https://en.wikipedia.org/wiki/HMS_Rattler_(1843))
  - [https://en.wikipedia.org/wiki/Steam\\_engine#Marine\\_engines](https://en.wikipedia.org/wiki/Steam_engine#Marine_engines)
  - [https://en.wikipedia.org/wiki/Steam\\_turbine](https://en.wikipedia.org/wiki/Steam_turbine)
  - [https://en.wikipedia.org/wiki/Trireme#:~:text=A%20trireme%20\(%2F%CB%88tr,Phoenicians%2C%20ancient%20Greeks%20and%20Romans.](https://en.wikipedia.org/wiki/Trireme#:~:text=A%20trireme%20(%2F%CB%88tr,Phoenicians%2C%20ancient%20Greeks%20and%20Romans.)
  - <https://lakeroland.org/wp-content/uploads/2018/09/Dugout-Canoe-2.pdf>

### ➤ **Youtube Videos**

- <https://www.youtube.com/watch?v=zenMEj0cAC4>
- <https://www.youtube.com/watch?v=CkZszsl2aIU>
- <https://www.youtube.com/watch?v=VHXYoY8BvoE>
- <https://www.youtube.com/watch?v=vaL6LFQHD-k>
- <https://www.youtube.com/watch?v=4x04M8YwOBw>
- <https://www.youtube.com/watch?v=VWn8gQ9Ykpk>
- <https://www.youtube.com/watch?v=KMXJZh0pDC8>
- <https://www.youtube.com/watch?v=ESfSG2OIQYQ>
- <https://www.youtube.com/watch?v=cPIcoaWPcIg>
- <https://www.youtube.com/watch?v=GMgP-4O99qU>
- <https://www.youtube.com/watch?v=QltRwiu4U2Q>